

MEMS SPEAKER

CONAMARA UA-C0601-2T ENGINEERING SAMPLES DATASHEET

U))) SOUND



The Conamara UA-C0601-2T speaker is designed as a tweeter for personal audio products, such as in-ear wired earphones or true wireless stereo earbuds (TWS). Its state-of-the-art MEMS technology allows reaching maximum efficiency, covering the high-frequency range at the smallest speaker thickness available on the market. Due to its round form factor, low weight, and thickness, Conamara UA-C0601-2T allows easy integration into existing audio products enhancing high-frequency performance.

FEATURES

- High bandwidth frequency range (2 kHz – 80 kHz)
- Enabling Hi-Res audio solutions
- Ultra-slim form factor: $\varnothing 6.0 \times 1.44$ mm
- Competitive sound pressure level
- Low temperature reflow solderable (200°C)
- Seamless integration into acoustical devices
- No magnetic field
- Low heat generation

APPLICATIONS

Conamara UA-C0601-2T is the perfect tweeter for 2-way in-ear audio systems such as wired earphones and true wireless systems (TWS). Furthermore, it can act as speaker in OTC hearing aids to increase the SPL at mid to high frequencies.

CONTENT

SPECIFICATIONS	3
MECHANICAL DIMENSIONS	4
TEST CONDITIONS	5
ACOUSTIC PERFORMANCE	6
REFERENCE DRIVING CIRCUIT	8
HANDLING	9
CONNECTIVITY	10
REFLOW SOLDERING PROFILE	11

REVISION HISTORY

September 2022: Release

September 2022: Update of mechanical dimensions, page 4; correction of schematics, page 8; addition of the reflow soldering profile, page 11.

SPECIFICATIONS

Nominal driving conditions, if not otherwise noted: $2.5 V_{\text{RMS}}$ ($3.5 V_{\text{p}}$), no V_{DC} required.

General Acoustics			
f_{res}	[kHz]	5.4	$\pm 10\%$
Q-factor	[-]	1.8	
Effective membrane surface – S_{D}	[mm ²]	13.6	
Equivalent volume – V_{AS}	[mm ³]	20	
Back volume inside speaker	[mm ³]	9.4	

Acoustics in coupler (IEC 60318-4)			
SPL @ 1 kHz / $2.5 V_{\text{RMS}}$ ($3.5 V_{\text{p}}$)	[dB]	97	± 3
SPL @ 5 kHz / $2.5 V_{\text{RMS}}$ ($3.5 V_{\text{p}}$)	[dB]	110	± 3
SPL @ 10 kHz / $2.5 V_{\text{RMS}}$ ($3.5 V_{\text{p}}$)	[dB]	109	± 3
SPL @ 1 kHz / $7 V_{\text{RMS}}$ ($10 V_{\text{p}}$) + $10 V_{\text{DC}}$	[dB]	106	± 3
SPL @ 5 kHz / $7 V_{\text{RMS}}$ ($10 V_{\text{p}}$) + $10 V_{\text{DC}}$	[dB]	119	± 3
SPL @ 10 kHz / $7 V_{\text{RMS}}$ ($10 V_{\text{p}}$) + $10 V_{\text{DC}}$	[dB]	118	± 3
THD @ 1 kHz / $2.5 V_{\text{RMS}}$ ($3.5 V_{\text{p}}$)	[%]	1.4	+0.1
THD @ 5 kHz / $2.5 V_{\text{RMS}}$ ($3.5 V_{\text{p}}$)	[%]	1.1	+0.1
THD @ 10 kHz / $2.5 V_{\text{RMS}}$ ($3.5 V_{\text{p}}$)	[%]	0.6	+0.1

Electronics			
Capacitance	[nF]	22	± 5

Operating conditions			
Maximum positive voltage	[V]	20	
Minimum negative voltage	[V]	-5	
Upper operating frequency limit	[kHz]	>80	

MECHANICAL DIMENSIONS

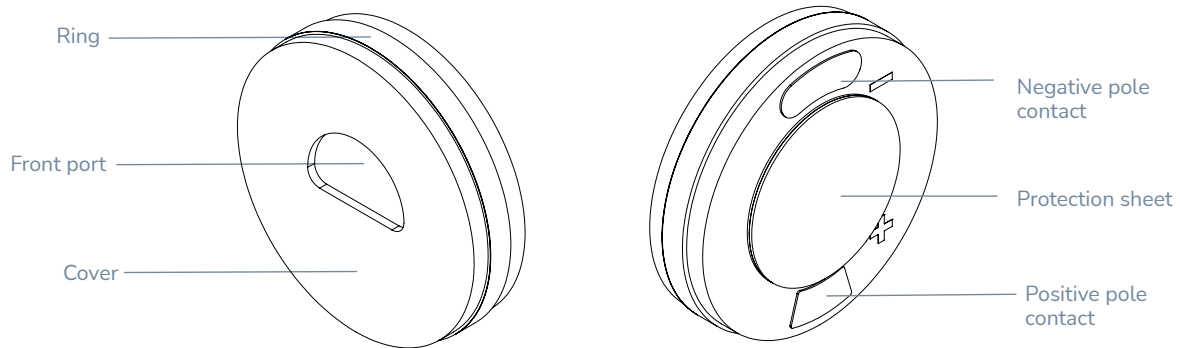

Figure 1: Speaker perspective view.

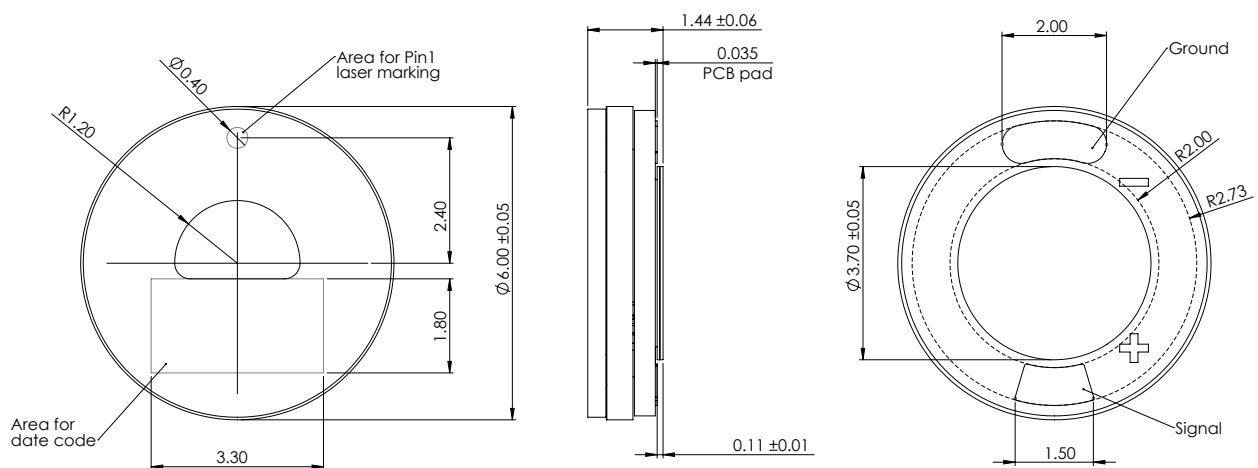

Figure 2: Speaker top/side/bottom views. Dimensions in mm.

Dimensions		
Size	[mm]	∅ 6.0 x 1.44
Total speaker weight	[mg]	96

TEST CONDITIONS

General	
Measurement system	Audio Precision APx
Measurement signal	Exp. Sweep
Voltage levels V_{AC}	$2.5 V_{RMS} (3.5 V_P) // 7 V_{RMS} (10 V_P) + 10 V_{DC}$
Applied back volume	Open (infinite)
Coupler (IEC 60318-4)	
Coupler type	IEC 60318-4 ('711')
Coupler volume	1.26 cm ³
Connection tube length	1.5 mm
Connection tube diameter	4.0 mm
Microphone	GRAS 43AC

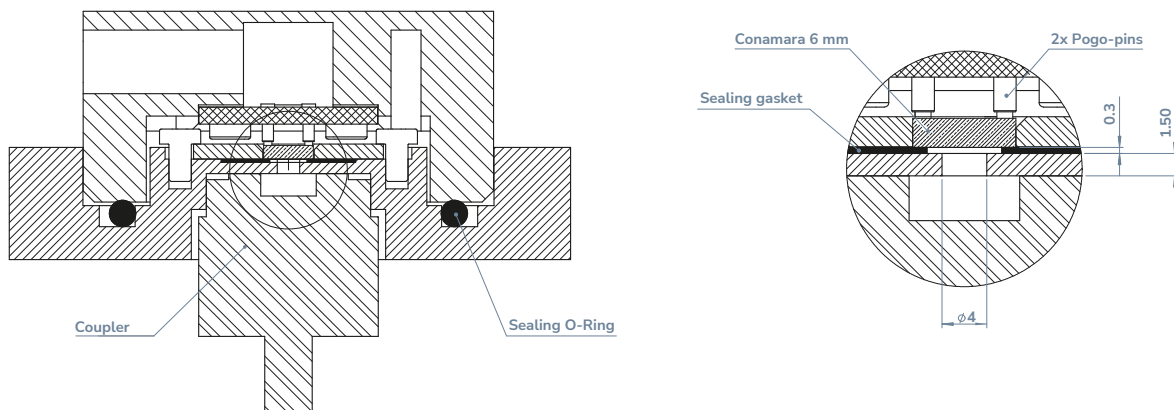

Figure 3: Coupler adapter cross-section. The speaker adapter is directly screwed onto the coupler; the ear mold adapter is not used. The outlet for the speaker is round with a diameter of 4 mm and length of 1.5 mm.

USound offers a speaker evaluation kit (Carme kit UJ-E1040C06) to replicate the coupler adapter design above. By using the Carme kit, the same results as in the data sheet can be obtained.

ACOUSTIC PERFORMANCE

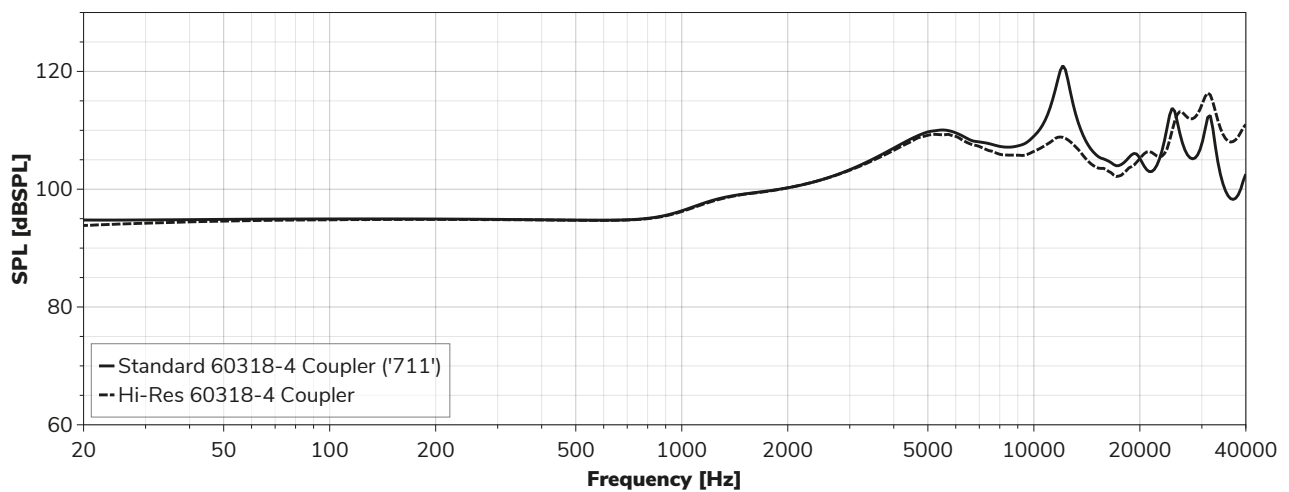

Figure 4: SPL at $2.5 V_{RMS}$ ($3.5 V_p$) drive, measured with the standard 711-Coupler (IEC 60318-4) and with the Hi-Res Coupler from GRAS, the latter replicates the frequency response above 10 kHz more accurately

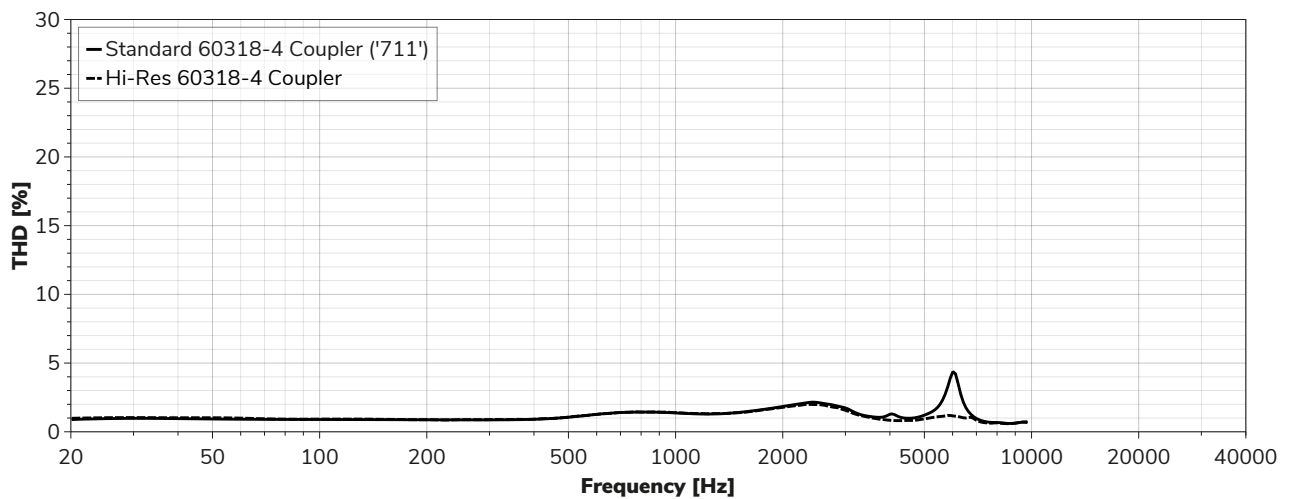

Figure 5: THD at $2.5 V_{RMS}$ ($3.5 V_p$) drive, measured with the standard 711-Coupler (IEC 60318-4) and with the Hi-Res Coupler at $10 V_p + 10 V_{DC}$ from GRAS. The latter replicates the frequency response above 10 kHz more accurately

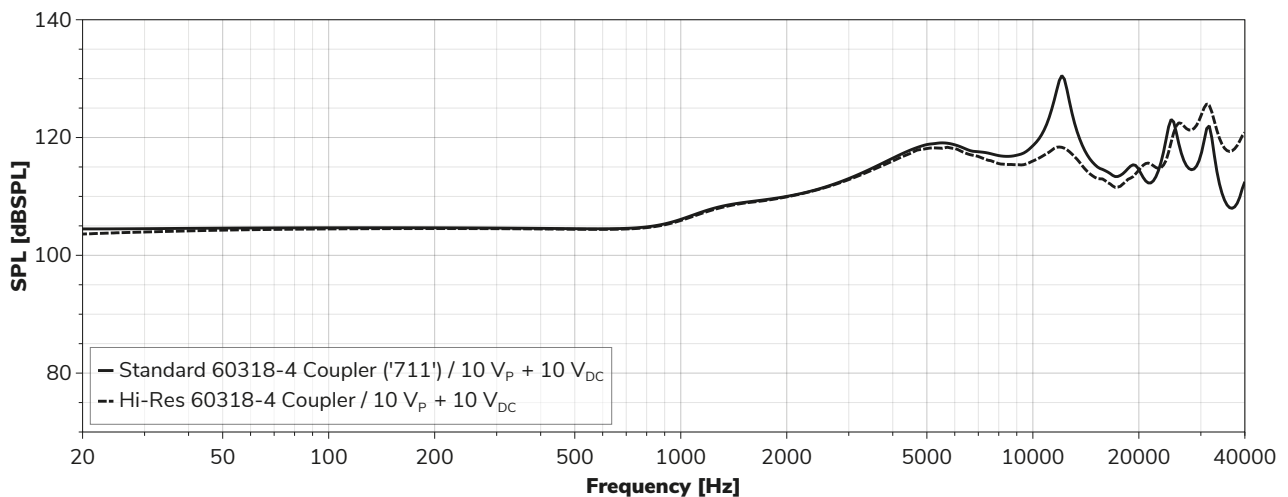

Figure 6: SPL at $7 V_{RMS}$ ($10 V_p$) + $10 V_{DC}$ drive, measured with the standard 711-Coupler (IEC 60318-4) and with the Hi-Res Coupler from GRAS, the latter replicates the frequency response above 10 kHz more accurately

The Active Linearization Algorithm ('ALA') is a signal processing algorithm developed by USound that optimizes the audio signal to compensate for non-linearities in the speaker. Applying it lowers the THD further while keeping the SPL unchanged (difference below 0.5 dB). The THD stays below 0.8% over the whole frequency range when using the standard Coupler IEC 60318-4 (Figure 7).

Please refer to the whitepaper [Active Linearization Algorithm for USound MEMS Speakers](#), available to download on the USound website, or contact sales@usound.com for further support.

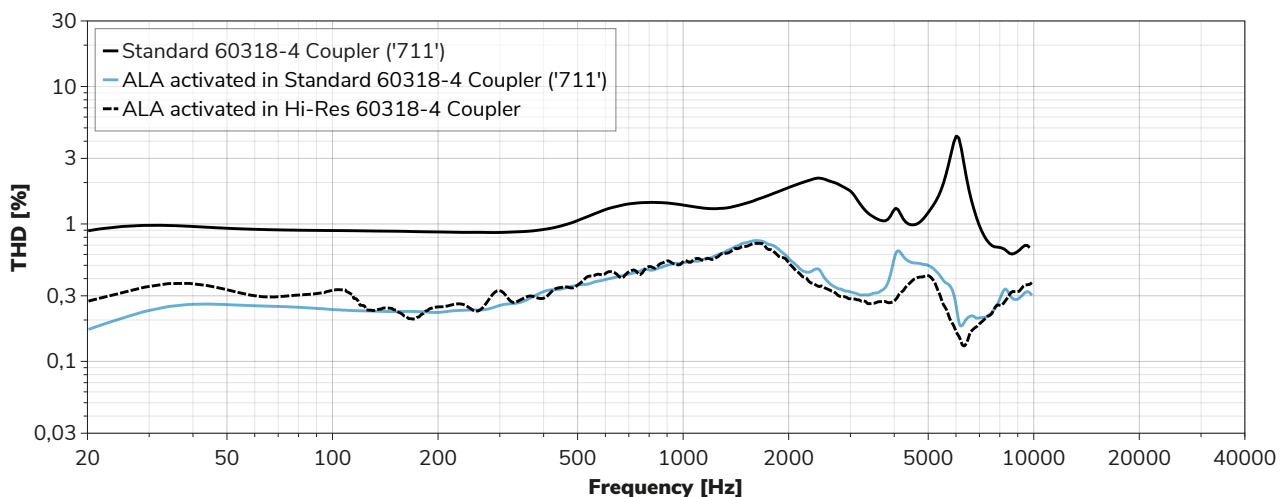

Figure 7: THD at $2.5 V_{RMS}$ ($3.5 V_p$) drive (in logarithmic scale), measured with and without the ALA (see above) with the standard 711-Coupler (IEC 60318-4) and with the Hi-Res Coupler from GRAS. The latter replicates the frequency response above 10 kHz more accurately.

REFERENCE DRIVING CIRCUIT

In Figure 8, the reference driving circuit is shown. It utilizes the amplifier MAX98309. The circuit itself is based on the typical application diagram from the MAX98309 datasheet, the amplifier is configured with a differential input signal but can also be modified according to the datasheet to a single-ended input.

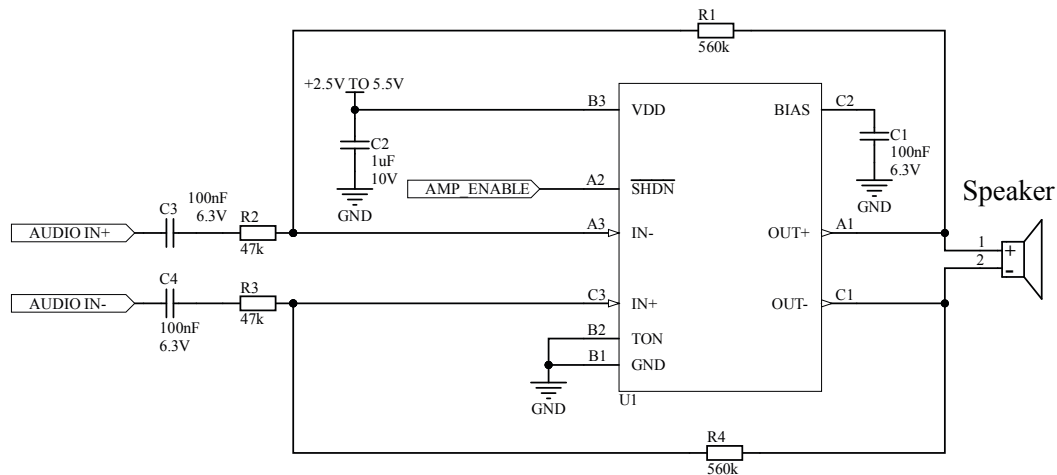

Figure 8: MAX98309 amplifier, including required passive components.

The gain (A_v) is defined by the feedback resistance R_f (R1 and R4) and input resistance R_{in} (R2 and R3): $A_v = R_f/R_{in}$. The default gain, shown in the circuit above, is 11.9 V/V (21.5 dB). It is recommended to choose the lowest gain that satisfies the output amplitude needs, as the overall noise will be the lowest.

In order to achieve the normal driving conditions for the MEMS speaker UA-C0601-2T the supply voltage for the MAX98309 is recommended to be 3.6V (or higher). This will allow for speaker voltages up to $3.5 V_p$. For higher voltages (for example $10 V_p + 10 V_{DC}$) the TI LM48580 is recommended.

For support on the TI LM48580 amplifier implementation or assistance on the cross-over design, please get in contact with the USound team (sales@usound.com).

HANDLING

GENERAL

It needs to be considered that MEMS devices consist of silicon structures, and therefore, they should be handled with care. Any bending of the MEMS speakers must be avoided while handling during the assembly process, otherwise the speaker can be damaged.

TWEEZERS

It is recommended to gently grip the speakers from the sides with blunt curved tweezers and avoid touching the membrane to preserve its functionality and form (Figure 9). Using sharp tweezers while manipulating the speakers can lead to accidentally piercing the membrane to a loss of functionality. The risk to damage the speaker can be further minimized if the speaker is handled with the membrane facing down, as shown in the picture below.



Figure 9: Left: not recommended tweezer type. Right: recommended tweezer type.

CONNECTIVITY

The speaker is driven by applying a voltage between the “+” and the “-” contacts. The bigger pad corresponds to the negative input, the smaller pad to the positive input (Figure 10).

For driving the speaker with voltages above $5 V_p$, an additional DC needs to be added to the signal, increasing the voltage potential on the “+” contact. The recommended DC level in this case is $10 V_{DC}$. This allows AC voltages up to $7 V_{RMS}$ ($10 V_p$)

A positive voltage on the positive pad will result in the membrane moving up (away from the pads).

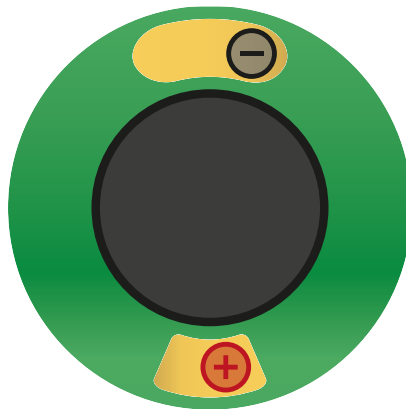

Figure 10: Electrical contacts of the MEMS speaker

REFLOW SOLDERING PROFILE

Conamara UA-C0501-2T allows low temperature reflow soldering with a peak temperature of 200°C. The reflow soldering profile is presented on Figure 11. The recommended parameters are presented in the Table 1. More than one reflow cycle is not recommended. The performance change between before/after reflowing is negligible.

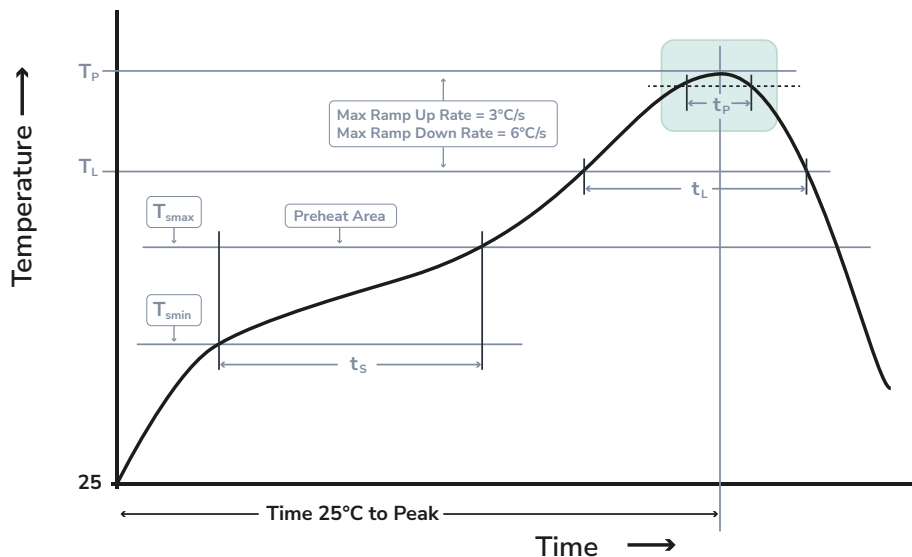

Figure 11: Reflow profile.

Step	Temperature T [°C]	Duration t [s]
Preheat	$T_{Smin} = 110$ $T_{Smax} = 145$	$t_{Smax} = 60$
Liquidous	$T_{Lmax} = 157$	$t_{Lmax} = 120$
Peak	$T_{Pmax} = 200$	$t_{Pmax} = 20$
Time 25 °C to Peak	-	$t_{max} = 240$

Table 1: Reflow soldering profile parameters overview.

SIMILAR PRODUCTS

Product Name	Description
Conamara 5 mm UA-C0501-2T	MEMS speaker for 2-way speaker solution in wearables and hearables, tweeter, 5 mm diameter.
Conamara 6 mm UA-C0601-2F	MEMS speaker for wearables and hearables, full bandwidth, 6 mm diameter.

COMPATIBLE PRODUCTS

Product Name	Description
Amalthea 1.0 UA-R3010	MEMS speaker array amplifier with a frequency range up to 80 kHz, can drive up to 40 MEMS speakers, including heatsink housing
Helike 1.0 UA-E3010	Development board for evaluating, rapid prototyping and designing audio solutions using USound MEMS speaker technology.
Carme kit 6 mm UJ-E1040C06	A speaker evaluation kit for testing the acoustic performance of the USound MEMS speaker Conamara 6 mm UA-C0601-2T.

IMPORTANT NOTICE AND DISCLAIMER

USound GmbH (“USound”) makes no warranties for the use of USound products, other than those expressly contained in USound’s applicable General Terms of Sale, located at www.usound.com. USound assumes no responsibility for any errors which may have crept into this document, reserves the right to change devices or specifications detailed herein at any time without notice, and does not make any commitment to update the information contained herein. No license to patents or other intellectual property rights of USound are granted in connection with the sale of USound products, neither expressly nor implicitly.

In respect of the intended use of USound products by the customer, the customer is solely responsible for observing existing patents and other intellectual property rights of third parties and for obtaining, as the case may be, the necessary licenses. For more information about USound patents visit <https://www.usound.com/patents/>.

Important note: The use of USound products as components in medical devices and/or medical applications, including but not limited to, safety and life supporting systems, where malfunctions of such USound products might result in damage to and/or injury or death of persons is expressly prohibited, as USound products are neither destined nor qualified for use as components in such medical devices and/or medical applications. The prohibited use of USound products in such medical devices and/or medical applications is exclusively at the risk of the customer.