

P	LTR	DESCRIPTION	DATE	DWN	APVD
A	I	REVISED ECR-10-019374	17SEP2010	T.T	T.M
B		REVISED	26FEB2021	H.O	E.I

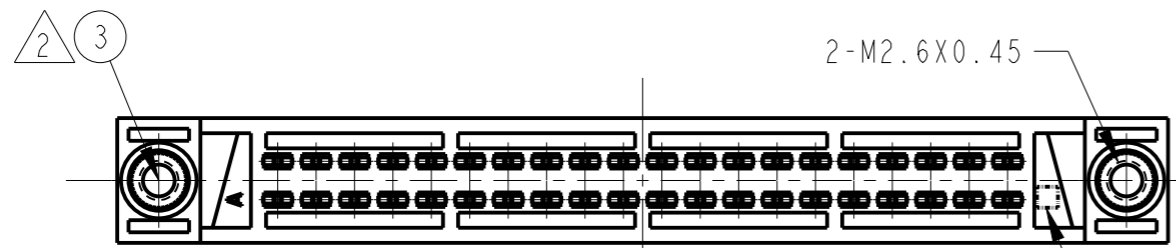

- 1 金めっき範囲.
- 2 FIXED NUTはトルク8kg・cmにて空回りしないこと。
- 3. 基板側のネジ"が締め付けられていない時は、嵌合側のネジ"を締め付けてはならない。
- 1 Au PLATING AREA.
- 2 TORQUE: 8kg・cm MIN.
- 3. WHEN THE SCREW BY THE SIDE OF BOARD IS NOT BOLTED, DON'T BOLT THE SCREW BY THE SIDE OF MATE.

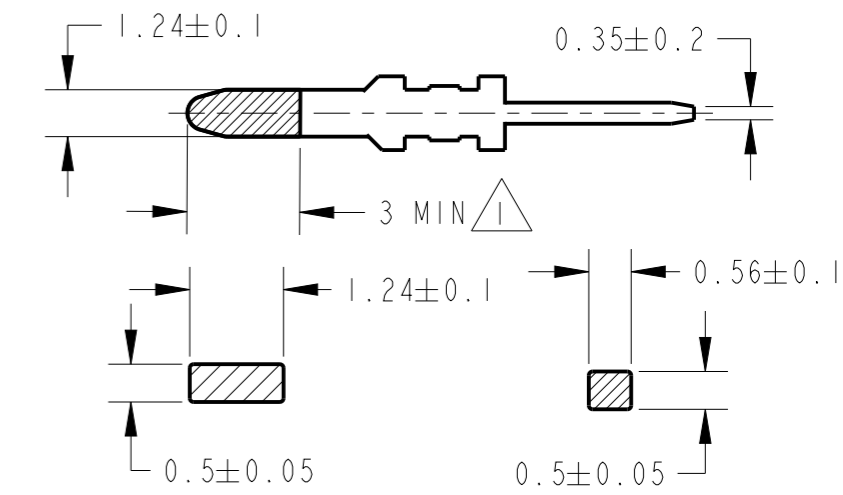
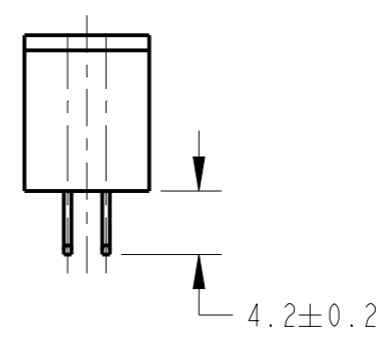
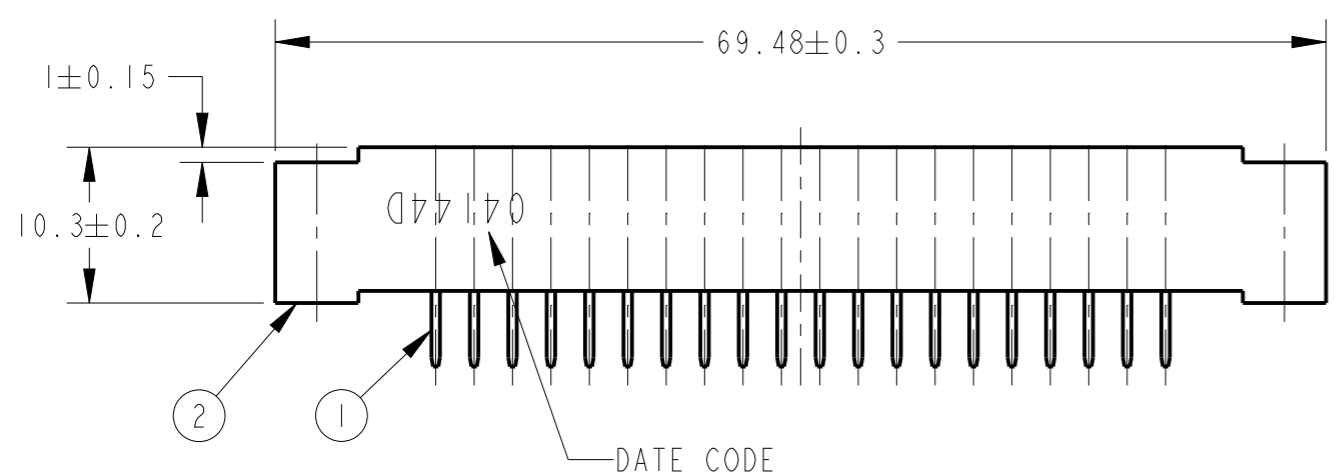
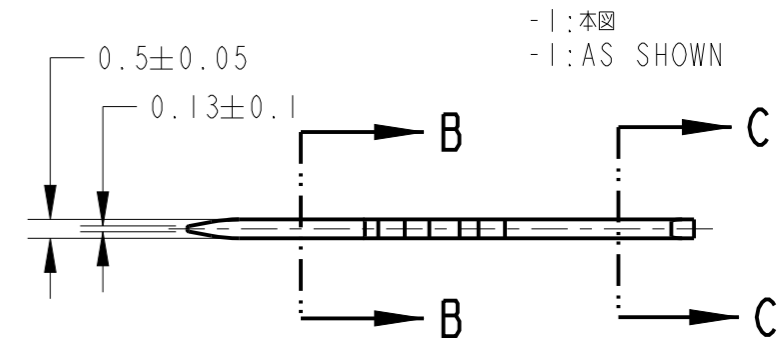
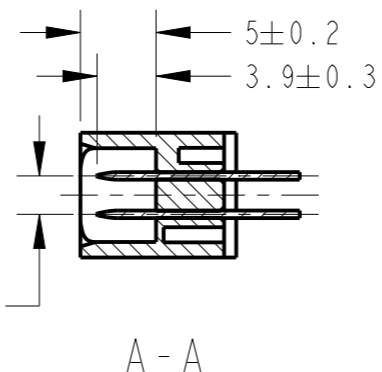
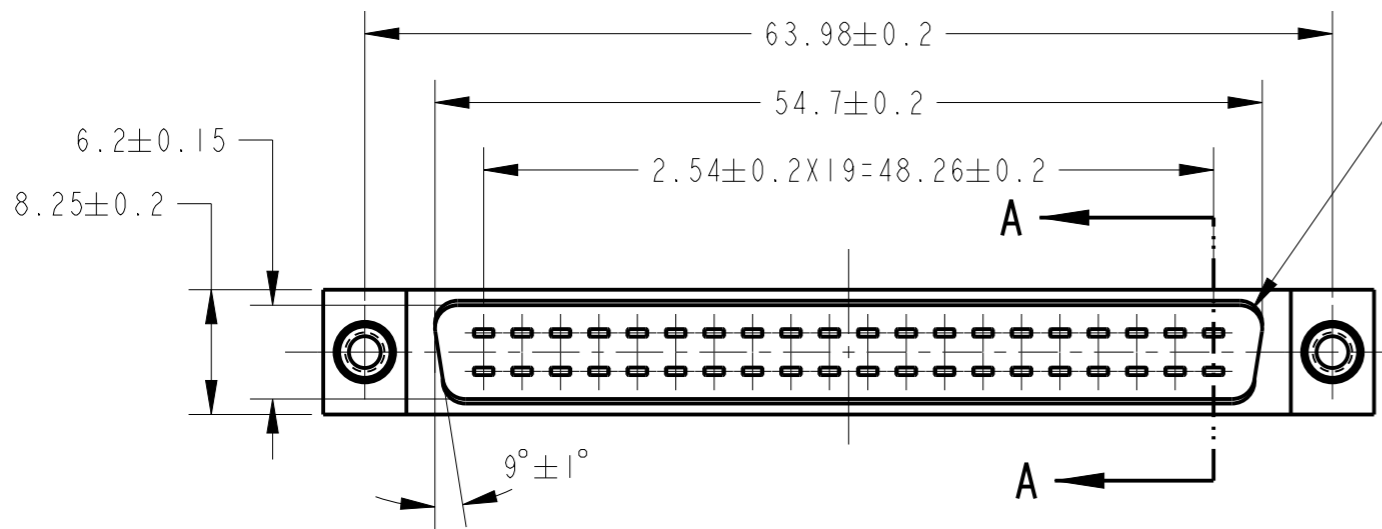
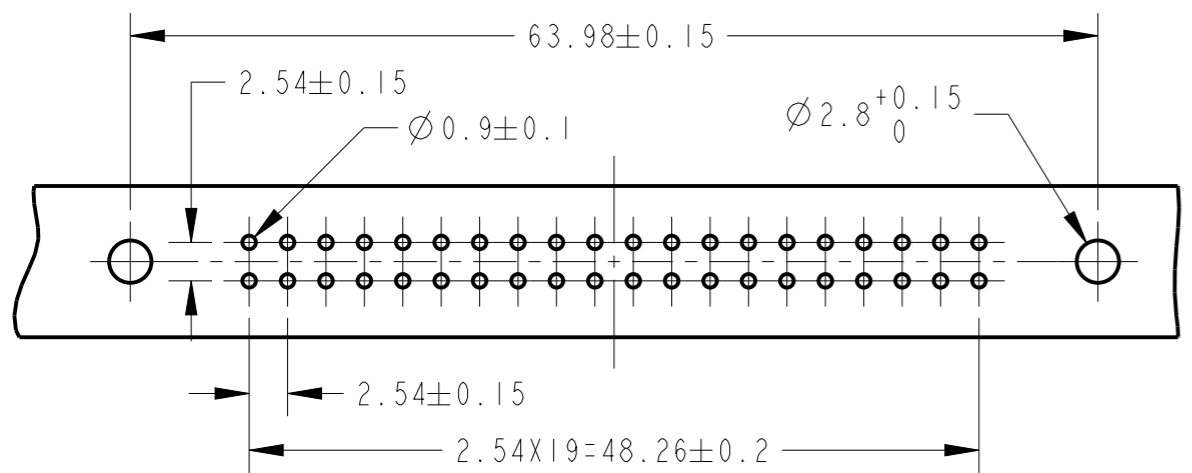

ITEM No.	NAME	FINISH	MATERIAL
3	FIXED NUT		BRASS
2	HDR HOUSING		THERMOPLASTIC POLYESTER(BLACK)
1	TAB POST	UNDER Ni, CONTACT AREA Au PL.0.3µMIN.TIN PLT.AT POST AREA.	BRASS

推奨基板寸法 (1.6±0.2)
RECOMMENDED P.C.BOARD DIM. (1.6±0.2)

THIS DRAWING IS A CONTROLLED DOCUMENT.

DIMENSIONS:	TOLERANCES UNLESS OTHERWISE SPECIFIED:
単位: 概 mm	一般公差 ± -
	0 PLC ± -
	1 PLC ± -
	2 PLC ± -
	3 PLC ± -
	4 PLC ± -
	ANGLES ± -
MATERIAL 材料	FINISH 仕上

DWN	J. AKASAKA	13FEB2004
CHK	D. MITSUGI	18MAR2004
APVD	S. MANABE	18MAR2004
PRODUCT SPEC	製品規格	108-5542
APPLICATION SPEC	取付適用規格	
WEIGHT		
CUSTOMER DRAWING		

WIRE RANGE 包合電線断面積 - INSULATION DIA 被覆外径 -

STE TE Connectivity

NAME 名称 40P HDR ASSY - V TYPE
PC. I/O CONN.

SIZE	CAGE CODE	DRAWING NO 番号	RESTRICTED TO
A3	00779	C=1747053	

SCALE 尺度 2:1 SHEET 1 OF 1 REV B