



FEATURES:

- Super wide Input range
- Extremely High Input range up to 1500VDC
- Operating temperature of -40 to +70°C
- Over current and Over Voltage protection
- No minimum load required
- High efficiency of up to 80%
- I/O Isolation of 4000VAC
- Reversed connection protection



Models
Single output

Model	Input Voltage (V)	Output Voltage (V)	Output Current max (A)	Isolation (VAC)	Max Capacitive Load(uF)	Efficiency (200VDC) (%)
AM15W-60012S-NZ**	100-1000	12	1.25	4000	2000	77
AM15W-60015S-NZ**	100-1000	15	1	4000	1200	78
AM15W-60024S-NZ**	100-1000	24	0.625	4000	470	80
AM15W-80012S-NZ***	200-1500	12	1.25	4000	2000	71*
AM15W-80015S-NZ***	200-1500	15	1	4000	1200	72*
AM15W-80024S-NZ***	200-1500	24	0.625	4000	470	74*

*Measured at 800VDC nominal input.

** For 600VDC input models add suffix “-ST” for optional screw terminal bottom plate or “-STD” for optional DIN Rail screw terminal bottom plate.

***For 800VDC input models add suffix “-ST” for optional DIN Rail screw terminal bottom plate with fuse and incorporated EMC filter or “-STS” for an optional DIN Rail screw terminal bottom plate only.

NOTE: All specifications in this datasheet are measured at an ambient temperature of 25°C, humidity<75%, nominal input voltage and at rated output load unless otherwise specified.

Input Specifications

Parameters	Nominal	Typical	Maximum	Units
Voltage range	600VDC		100-1000	VDC
	800VDC		200-1500	VDC
Input Current	600VDC input models, 200VDC		120	mA
	600VDC input models, 600VDC		40	mA
	600VDC input models, 1000VDC		22	mA
	800VDC input models, 200VDC		120	mA
	800VDC input models, 800VDC		30	mA
	800VDC input models, 1500VDC		16	mA
Inrush current	600VDC input models, 200VDC	7		A
	600VDC input models, 600VDC	20		A
	600VDC input models, 1000VDC	30		A
	800VDC input models, 200VDC	50		A
	800VDC input models, 1500VDC	150		A
External fuse	600VDC input models, Slow blow		2A/1500VDC	
	800VDC input models, Slow blow		4A/1500VDC	
Startup time	600VDC input models only		1	s
	800VDC input models only		3	s
Input under voltage protection	800VDC input models only, protection ON		170-185	VDC
	800VDC input models only, protection OFF		180-195	VDC

Isolation Specifications

Parameters	Conditions	Typical	Maximum	Units
Tested I/O voltage	1 min	4000		VAC

Output Specifications

Parameters	Conditions	Typical	Maximum	Units
Voltage accuracy	600VDC input models	±1	±2	%
	800VDC input models	±2		%
Line voltage regulation	600VDC input models	±0.5	±1	%
	800VDC input models	±1		%
Load voltage regulation	600VDC input models	±0.5	±1	%
	800VDC input models	±1		%
Over voltage protection	AM15W-60012S-NZ		15	VDC
	AM15W-60015S-NZ		19	VDC
	AM15W-60024S-NZ		28	VDC
	AM15W-80012S-NZ		20	VDC
	AM15W-80015S-NZ		20	VDC
	AM15W-80024S-NZ		30	VDC
Over current protection	600VDC input models	≥110		% of Iout
	800VDC input models	≥120		% of Iout
Short Circuit protection	Continuous			
Short circuit restart	Auto recovery			
Temperature coefficient		±0.02		%/°C
Ripple & Noise	20MHz Bandwidth, 600VDC input models	100	200	mV p-p
	20MHz Bandwidth, 800VDC input models	150	300	mV p-p

General Specifications

Parameters	Conditions	Typical	Maximum	Units
Switching frequency	600VDC input models, 100% load		75	KHz
	800VDC input models, 100% load	65		KHz
Operating temperature	With derating	-40 to 70		°C
Derating	600VDC input models, +50 to +70°C	2		%/°C
	800Vin, 12/15Vout, 200-300VDC, -40°C to 0°C	0.75		%/°C
	800Vin, 24Vout, 200-300VDC, -40°C to 0°C	1.5		%/°C
	800Vin, 1000-1500VDC, -40°C to -15°C	1.2		%/°C
	800VDC input models, +50°C to +70°C	1.5		%/°C
	800VDC input models, 2000m-5000m	6.7		%/km
Storage temperature	600VDC input models	-40 to 105		°C
	800VDC input models	-40 to 85		°C
Cooling	Natural convection			
Humidity			95	% RH
Case material	Heat resistant, black plastic (UL94-V0)			
Weight	600VDC input models, pin mountable	95		g
	600VDC input models, -ST mounting plate	150		g
	600VDC input models, -STD mounting plate	190		g
	800VDC input models, pin mountable	400		g
	800VDC input models, -ST mounting plate	710		g
	800VDC input models, -STS mounting plate	460		g
Dimensions (L x W x H)	600VDC input models, pin mountable	2.76 x 1.89 x 0.93inches, 70.0 x 48.0 x 23.5mm		
	600VDC input models, -ST mounting plate	3.78 x 2.13 x 1.26inches, 96.1 x 54.0 x 32.0mm		
	600VDC input models, -STD mounting plate	3.78 x 2.13 x 1.26inches, 96.1 x 54.0 x 36.6mm		
	800VDC input models, pin mountable	4.92 x 2.95 x 1.58inches, 125.0 x 75.0 x 40.0mm		
	800VDC input models, -ST mounting plate	5.75 x 5.43 x 2.17inches, 146.0 x 138.0 x 55.0mm		
	800VDC input models, -STS mounting plate	5.08 x 4.29 x 1.93inches, 129.0 x 109.0 x 49.0mm		
MTBF	>300,000 hrs (MIL-HDBK -217F, Ground Benign, t=+25°C)			
Soldering temperature	Manual soldering, duration 3 to 5 sec	360		°C
	Wave soldering, duration 5 to 10 sec	260		°C

Safety Specifications

Parameters		
Approvals	CE (for 800Vin models only)	
Standards	Design to meet CSA-C22.2 No.107.1-01, UL 1741, EN62109 (for 800Vin models only)	
	EMI - Conducted and radiated emission	EN55022, class A (with the recommended EMC circuit)
	Electrostatic Discharge Immunity	IEC 61000-4-2: Contact $\pm 6\text{KV}$ /Air $\pm 8\text{KV}$, Criteria B
	RF, Electromagnetic Field Immunity	IEC 61000-4-3: 10V/m, Criteria A
	Electrical Fast Transient/Burst Immunity (600Vin)	IEC 61000-4-4: $\pm 4\text{KV}$, Criteria B (with the recommended EMC circuit)
	Electrical Fast Transient/Burst Immunity (800Vin)	IEC 61000-4-4: $\pm 2\text{KV}$, Criteria B (with the recommended EMC circuit)
	Surge Immunity (600VDC Vin)	IEC 61000-4-5: $\pm 2\text{KV}$, Criteria B (with the recommended EMC circuit)
	Surge Immunity (800VDC Vin)	IEC 61000-4-5: $\pm 1\text{KV}$, Criteria B (with the recommended EMC circuit)
	RF, Conducted Disturbance Immunity	IEC 61000-4-6: 10Vrms, Criteria A
	Power frequency Magnetic Field Immunity (800Vin)	IEC 61000-4-8: 10A/m, Criteria A

*800VDC input models with -ST option do not require additional circuit to meet above standards.

Dimensions

600VDC input models

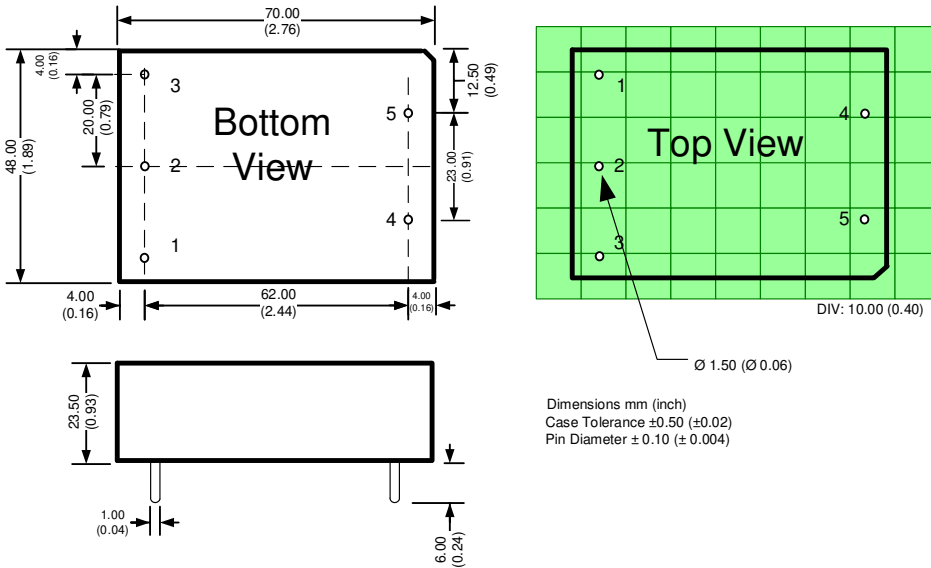

Pin Out Specifications

Pin	600VDC Input
1	N.C.
2	-Vin
3	+Vin
4	-Vout
5	+Vout

600VDC input models with optional -ST bottom plate

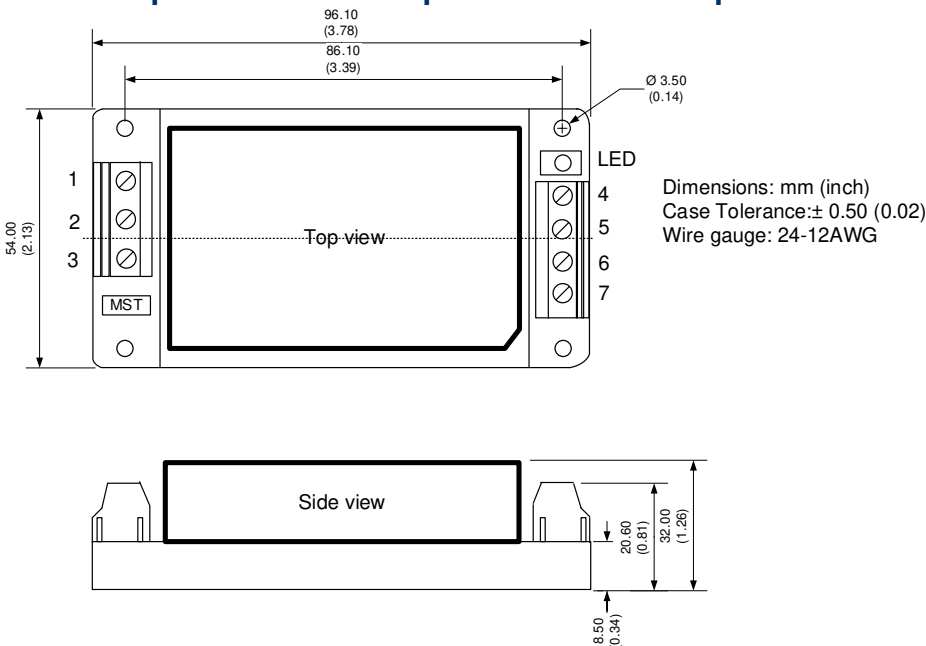

Pin Out Specifications

Pin	Single
1	-Vin
2	N.C.
3	+Vin
4	-Vout
5	N.C.
6	N.C.
7	N.C.
8	+Vout

600VDC input models with optional -STD bottom plate

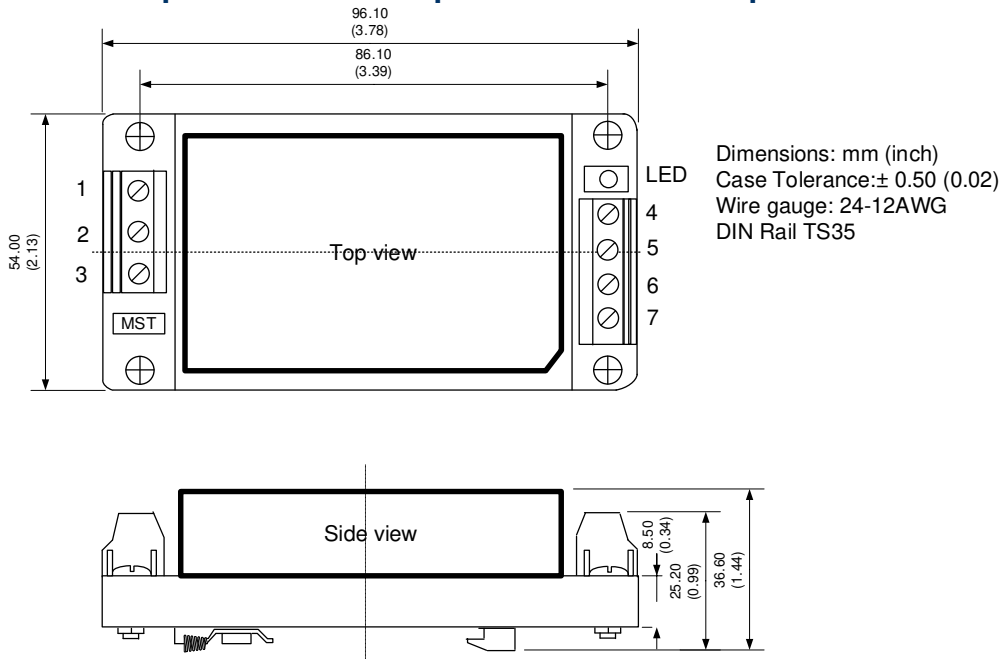

Pin Out Specifications

Pin	Single
1	-Vin
2	N.C.
3	+Vin
4	-Vout
5	N.C.
6	N.C.
7	+Vout

800VDC input models

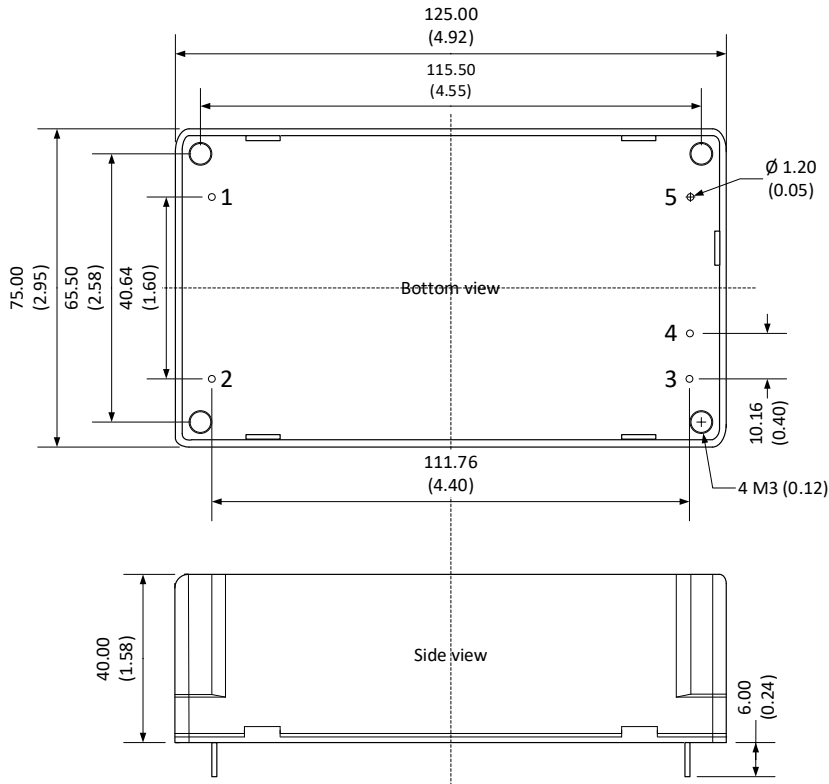

Pin Out Specifications

Pin	800VDC Input
1	+Vin
2	-Vin
3	+Vout
4	-Vout
5	N.C.

Dimensions mm (inch)
Case Tolerance ± 0.50 (± 0.02)
Pin Diameter Tolerance ± 0.10 (± 0.004)
Pin Length Tolerance ± 1.50 (± 0.06)

800VDC input models with optional -ST bottom plate

Pin Out Specifications

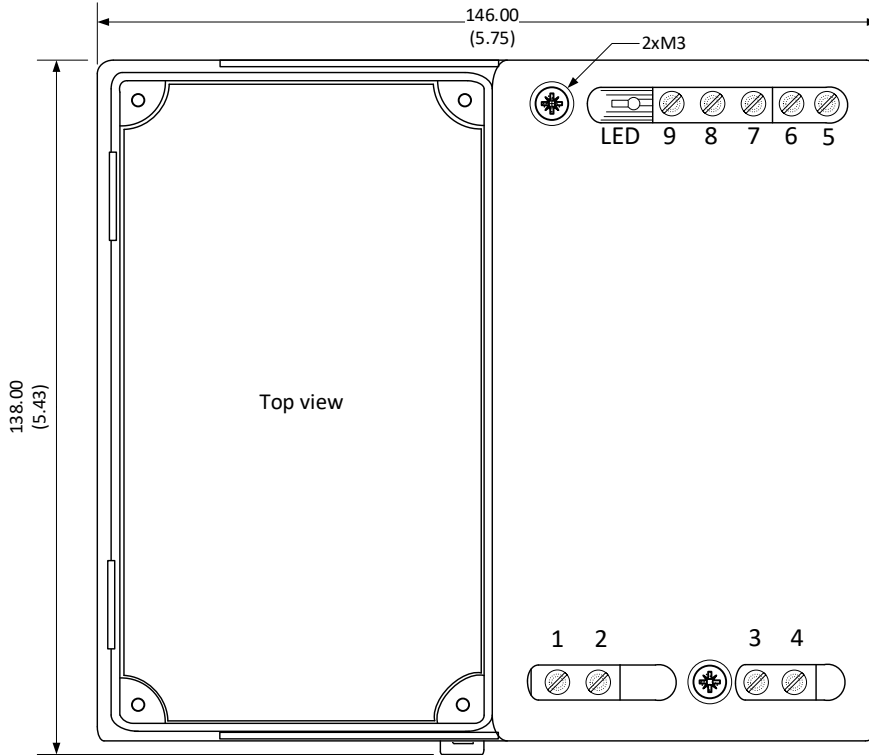

Pin	Single
1	-Vin
2	-Vin
3	+Vin
4	+Vin
5	+Vout
6	-Vout
7	N.C.
8	N.C.
9	N.C.

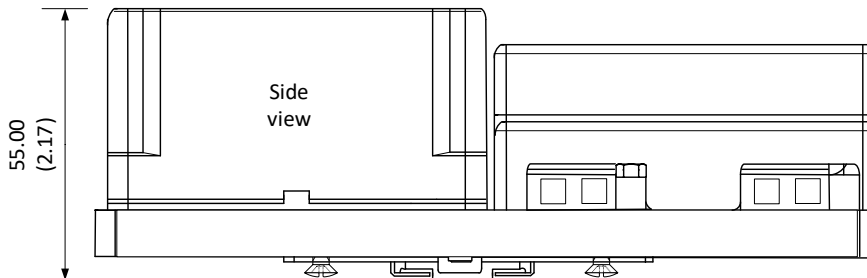

Dimensions mm (inch)
 Installed on DIN rail type TS35
 Wire: 24-12AWG
 Case Tolerance ± 0.50 (± 0.02)
 General Tolerance ± 1.00 (± 0.04)

NOTES:

1. To replace the internal fuse in the models with suffix "-ST", unscrew the 2 screws on the top side of the plate.
2. DIN rail metal holder needs to be grounded.
3. Horizontal mounting recommended.

800VDC input models with optional -STS bottom plate

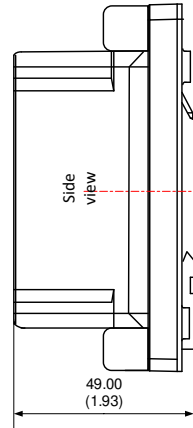
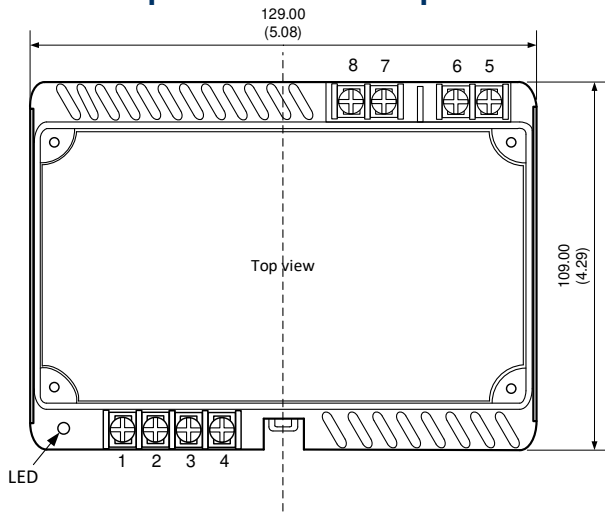

Dimensions mm (inch)
Installed on DIN rail type TS35
Wire: 24-12AWG
Tightening torque 0.4N-m max.
General Tolerance ± 1.00 (± 0.04)

Pin Out Specifications

Pin	Single
1	+V out
2	+V out
3	-V out
4	-V out
5	+V in
6	+V in
7	-V in
8	-V in

**Derating
600VDC input models**

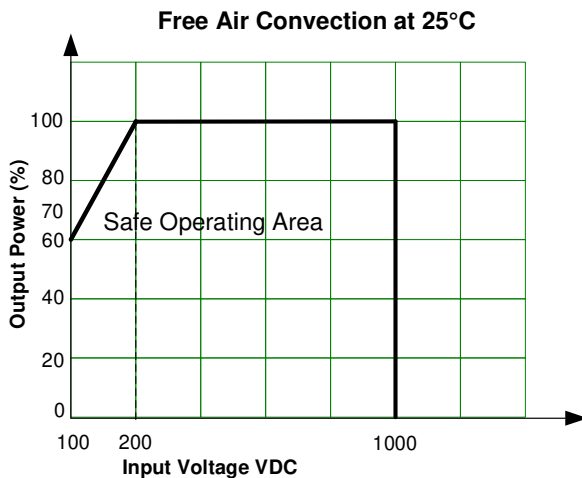
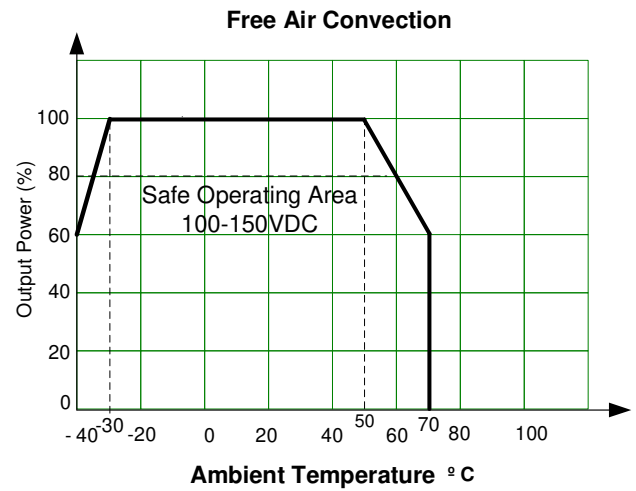
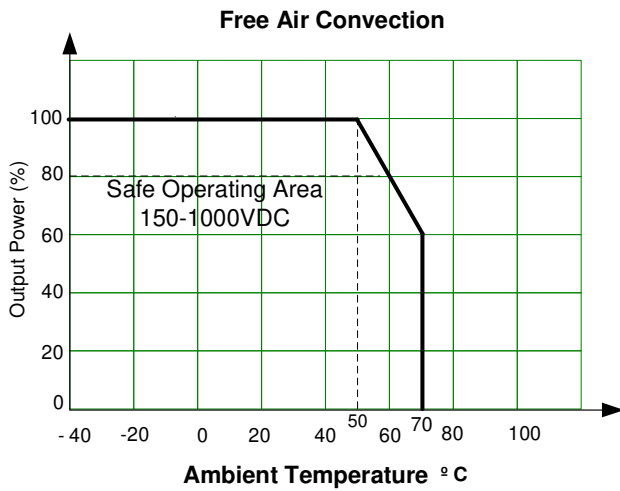

NOTE: 1. Derated Pout = Pout * temp. derating * Vin derating.
2. Sufficient air space for natural air flow around must be considered.

800VDC input models

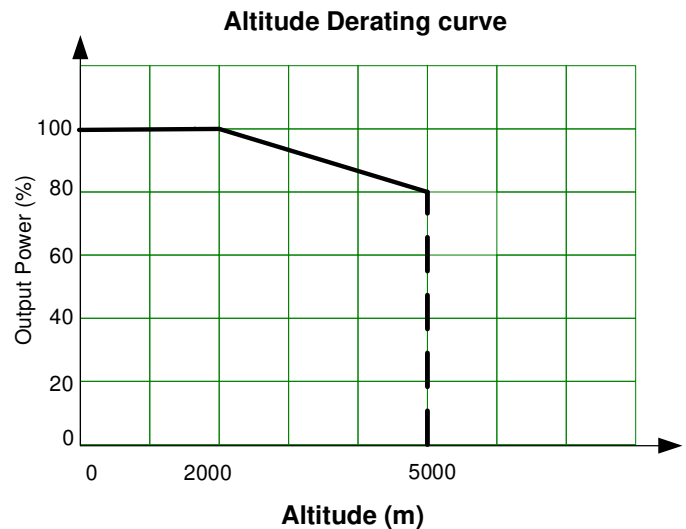
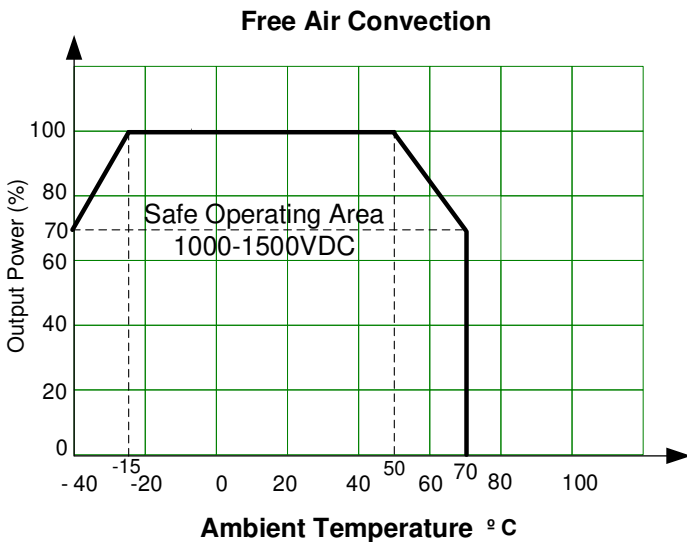
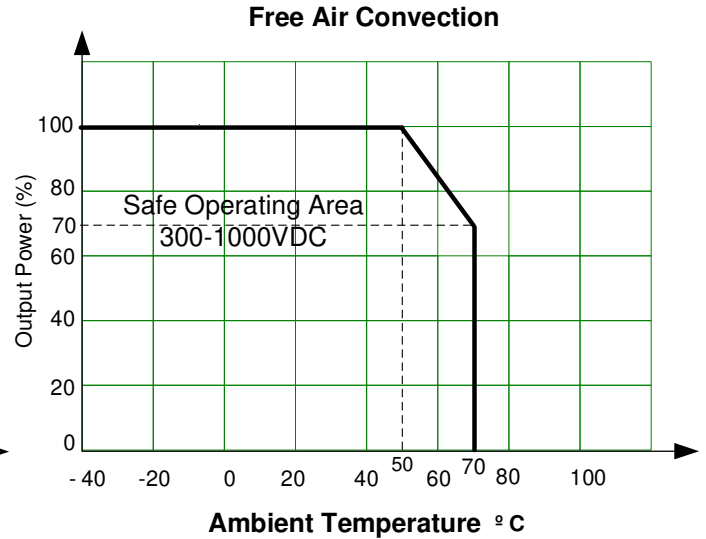
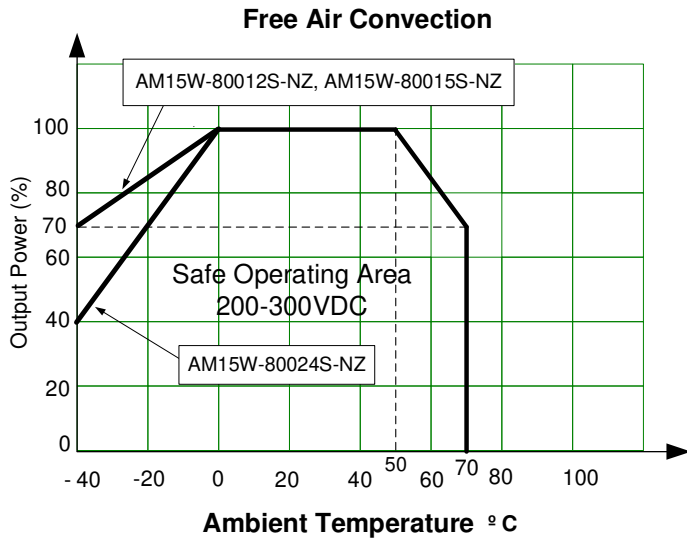

Typical Application circuit *

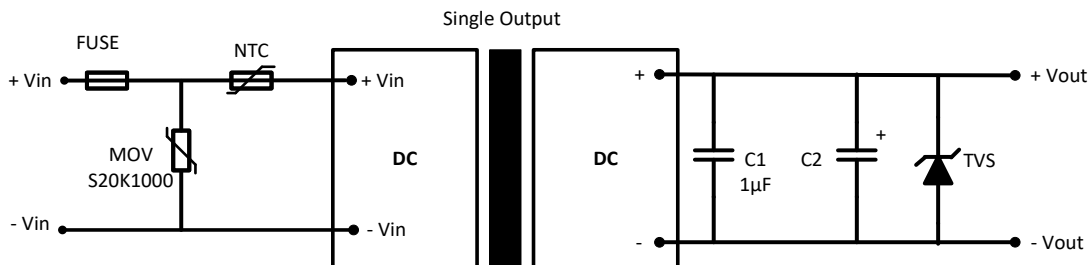

Model	C2	TVS
600VDC input models, 12 & 15 Vout	120µF	20V
600VDC input models, 24 Vout	68µF	33V
800VDC input models, 12 & 15 Vout	120µF	20V
800VDC input models, 24 Vout	68µF	30V

***NOTE:**
For 800VDC Input models NTC and MOV are not needed.
For 800VDC input models with suffix "-ST" this external circuit is not needed.
Choose capacitors with at least 20% voltage rating margin.

Recommended EMC Circuit

600VDC input models

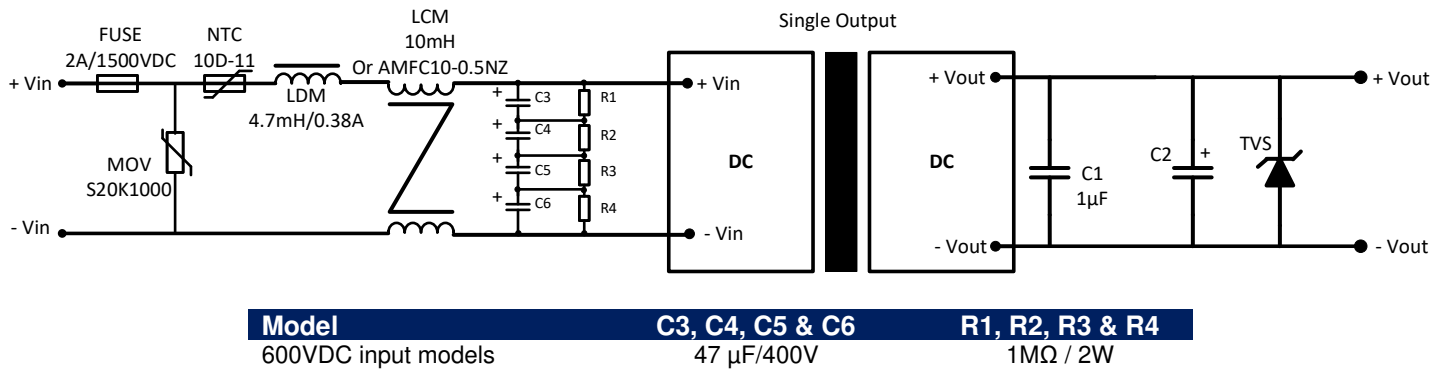

800VDC input models

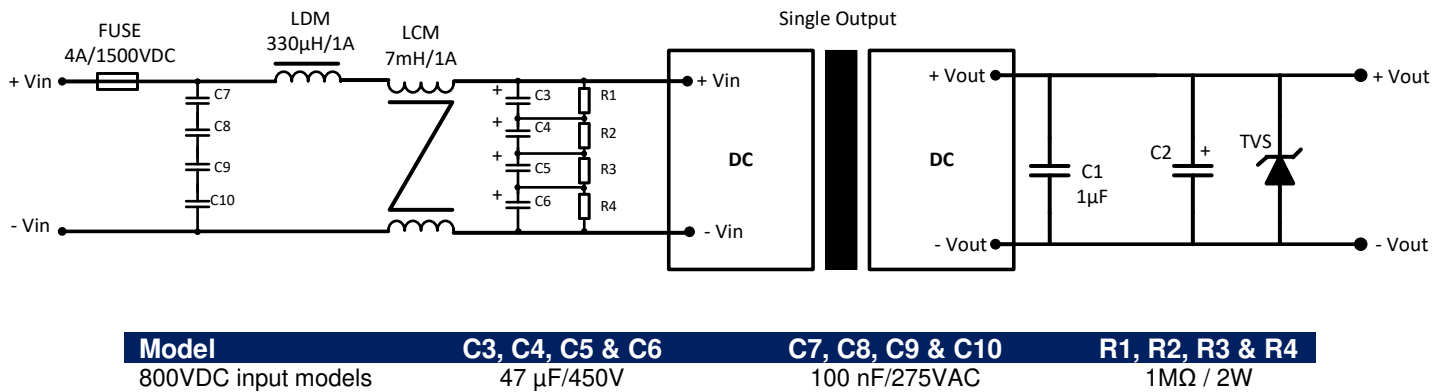

***NOTE:** For 800VDC input models with suffix “-ST” this external EMC circuit is not needed.

NOTE: 1. Datasheets are updated as needed and as such, specifications are subject to change without notice. Once printed or downloaded, datasheets are no longer controlled by Aimtec; refer to www.aimtec.com for the most current product specifications. 2. Product labels shown, including safety agency certifications on labels, may vary based on the date manufactured. 3. Mechanical drawings and specifications are for reference only. 4. All specifications are measured at an ambient temperature of 25°C, humidity < 75%, nominal input voltage and at rated output load unless otherwise specified. 5. Aimtec may not have conducted destructive testing or chemical analysis on all internal components and chemicals at the time of publishing this document. CAS numbers and other limited information are considered proprietary and may not be available for release. 6. This product is not designed for use in critical life support systems, equipment used in hazardous environments, nuclear control systems or other such applications which necessitate specific safety and regulatory standards other than the ones listed in this datasheet. 7. Warranty is in accordance with Aimtec’s standard Terms of Sale available at www.aimtec.com.