

NOTES:

1. MATERIALS AND FINISHES:
 BODY, RETAINING RING, WASHER,
 FERRULE AND BAYONET SLEEVE - BRASS, NICKEL PLATING
 OUTER CONTACT - BeCu, NICKEL PLATING
 CONTACT - PHOSPHOR BRONZE, GOLD PLATING
 INSULATORS - PTFE, NATURAL
 SPRING - STAINLESS STEEL, PASSIVATED
 GASKET - FLUOROSILICONE, BLACK

2. ELECTRICAL:
 A. IMPEDANCE: 75 OHM
 B. FREQUENCY RANGE: DC - 18 GHz
 C. RETURN LOSS: 20 dB MIN @ DC - 6 GHz
 15 dB MIN @ 6 - 12 GHz
 D. DIELECTRIC WITHSTANDING VOLTAGE: 1000 VRMS, MIN.
 E. INSULATION RESISTANCE: 10,000 MΩ MIN

3. MECHANICAL:
 A. DURABILITY: 500 CYCLES MIN.
 B. TEMPERATURE RANGE: -30° C TO +85° C

4. ENVIRONMENTAL:
 A. THERMAL SHOCK PER MIL-STD-202 METHOD 107
 TEST CONDITION B (EXCEPT HIGH TEMP @200°C)
 B. VIBRATION: MIL-STD-202 METHOD 204 TEST CONDITION B
 C. SHOCK: MIL-STD-202 METHOD 213 TEST CONDITION B
 D. CORROSION: MIL-STD-202 METHOD 101
 TEST CONDITION B 5% SALT SOLUTION

5. PACKAGING:
 A. QUANTITY: SINGLE PACK
 B. MARKING: BAG TO BE MARKED:
 "AMPHENOL RF, 34-1121-126 DATE CODE
 U.S. PATENT NO. 7,553,177"

6. HIGH DENSITY INSTALLATION/REMOVAL TOOL: 227-T2000-1694A.
 7. CABLE ASSEMBLY INSTRUCTIONS:
 A. TRIM CABLE AS SHOWN.
 B. CRIMP CONTACT TO CABLE CENTER CONDUCTOR
 WITH .042" SQUARE DIE
 C. CRIMP FERRULE WITH .278" HEX

8. SHOWS CABLE ENTRY DIMENSIONS.

THIRD ANGLE PROJ.

REVISIONS

REV	DESCRIPTION	DATE	ECO	APPR
A	RELEASE TO MFG.	25-May-18	08261	SV
B	NOTE 4 IN SHEET WAS CHANGED	7-Aug-18	08804	SH

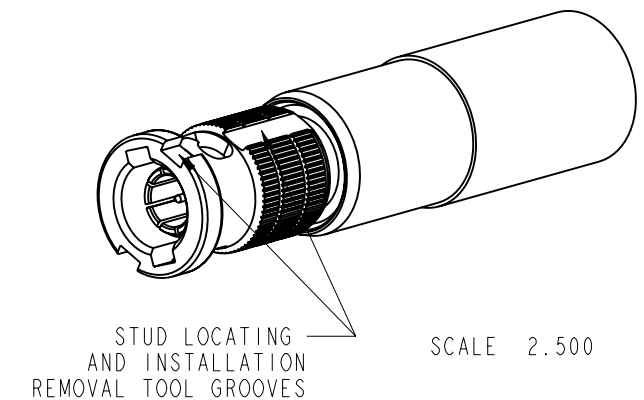
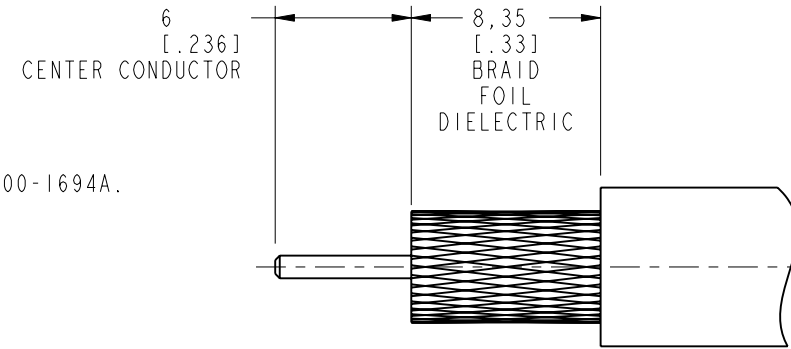

RECOMMENDED CABLE STRIPPING DIMENSIONS

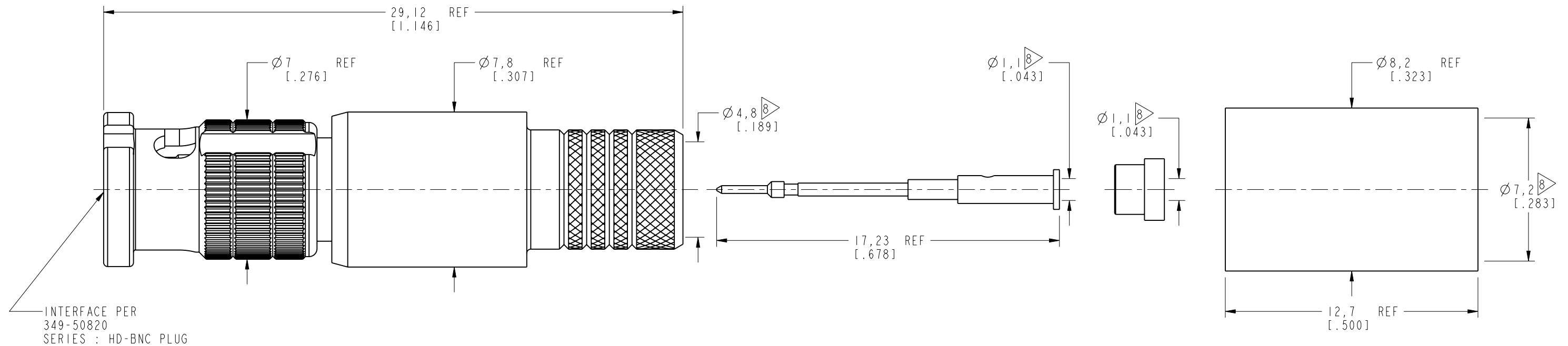

PROTECTED UNDER U.S. PATENT # 7,553,177

CUSTOMER OUTLINE DRAWING
 ALL OTHER SHEETS ARE FOR INTERNAL USE ONLY

UNLESS OTHERWISE SPECIFIED, DIMENSIONS ARE IN METRIC AND TOLERANCES ARE: <0.5mm ± 0.05mm 0.5 - 6mm ± 0.1mm 6 - 30mm ± 0.2mm 30 - 120mm ± 0.3mm ANGLES ± 1°	MATERIAL	DRAWN	DATE	TITLE HD-BNC STR PLUG FOR BELDEN 4694R CABLE	Amphenol RF www.amphenolrf.com
	SEE NOTES	W. ZENG	9-Aug-18		
NOTICE - These drawings, specifications, or other data (1) are, and remain the property of Amphenol corp. (2) must be returned upon request; and (3) are confidential and not to be disclosed to any person other than those to whom they are given by Amphenol Corp. the furnishing of these drawings, specifications, or other data by Amphenol Corp., or to any other person to anyone for any purpose is not to be regarded by implication or otherwise in any manner licensing, granting rights to permitting such holder or any other person to manufacture, use or sell any product, process or design, patented or otherwise, that may in any way be related to or disclosed by said drawings, specifications, or other data.	REFERENCE	ENGINEER	DATE	SCALE: 5.0:1.0	DRAWING NO. 34-1121-12G ITEM NO. 34-1121-12G PART NO. 34-1121-12G
	8048 AND --	SUNDE	8-Jun-18	SHEET 2 OF 2	
	CONFIGURATION LEVEL: In Work	APPROVED	DATE	DWG SIZE	REV
FINISH	S. HSIEH	10-Aug-18	B	B	