

注記 NOTES

- ① 材料及び仕上げ(めっき仕様) : TABLE 1, TABLE 2参照
MATERIAL AND FINISHES (PLATING SPECIFICATION) : SEE TABLE 1, TABLE 2
- ② 嵌合相手 : 505570シリーズ
MATE WITH : 505570 SERIES
- ③ 端子テール部及びネイルの平坦度 : 0.1mm以下
TAIL AND NAIL COPLANARITY : 0.1mm MAXIMUM
- ④ 極数=偶数に適用
APPLY FOR CIRCUIT SIZE=EVEN.
- ⑤ コネクタの仕様につきましては、製品仕様書(5055700001-PS PS 000)を参照して下さい。
PLEASE REFER TO THE PRODUCT SPECIFICATION (5055700001-PS PS 000)
- ⑥ 製品番号 MATERIAL No. 505575****

極数 CIRCUIT SIZE	↑↑↑
--------------------	-----

番号 NO.	カバーテープ COVER TAPE
7	無 WITHOUT
8	有 WITH

番号 NO.	ハウジング色 HOUSING COLOR
0	ナチュラル(白) NATURAL(WHITE)
1	黒 BLACK

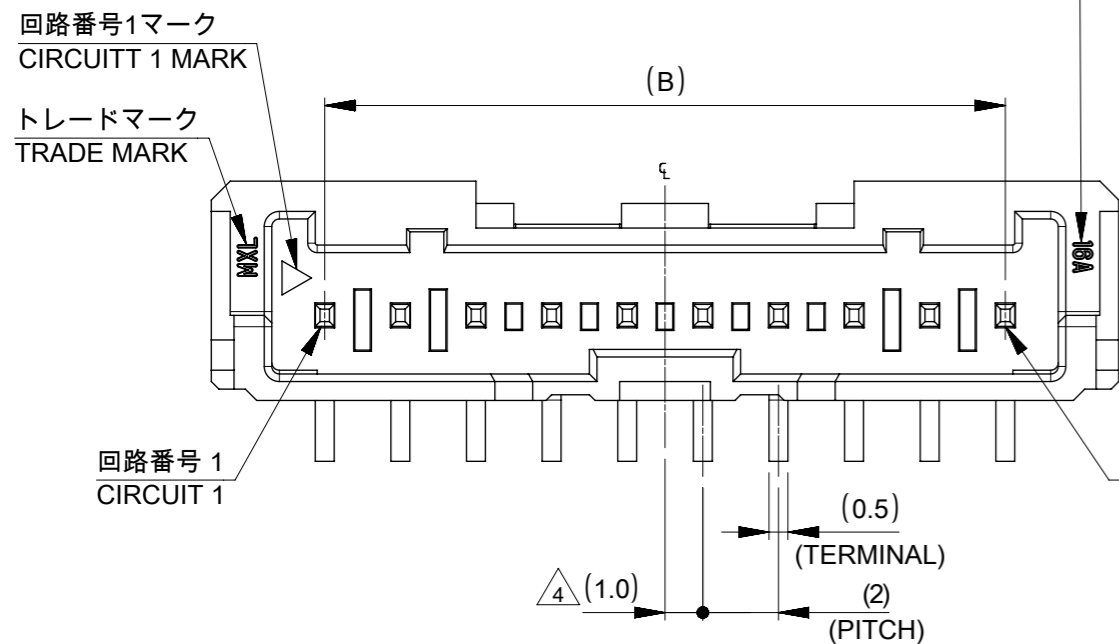

キャビティー及び金型番号
CAVITY & MOLD NO.

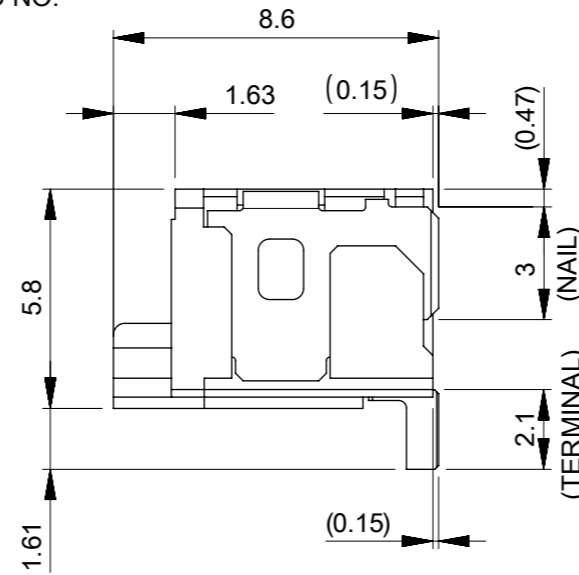

C	B	A	無 WITHOUT		有 WITH		カバーテープ COVER TAPE
			黒 BLACK	ナチュラル(白) NATURAL(WHITE)	黒 BLACK	ナチュラル(白) NATURAL(WHITE)	
34.53	30	36	5055751671	5055751670	5055751681	5055751680	16
32.53	28	34	5055751571	5055751570	5055751581	5055751580	15
30.53	26	32	5055751471	5055751470	5055751481	5055751480	14
28.53	24	30	5055751371	5055751370	5055751381	5055751380	13
26.53	22	28	5055751271	5055751270	5055751281	5055751280	12
24.53	20	26	5055751171	5055751170	5055751181	5055751180	11
22.53	18	24	5055751071	5055751070	5055751081	5055751080	10
20.53	16	22	5055750971	5055750970	5055750981	5055750980	9
18.53	14	20	5055750871	5055750870	5055750881	5055750880	8
16.53	12	18	5055750771	5055750770	5055750781	5055750780	7
14.53	10	16	5055750671	5055750670	5055750681	5055750680	6
12.53	8	14	5055750571	5055750570	5055750581	5055750580	5
10.53	6	12	5055750471	5055750470	5055750481	5055750480	4
8.53	4	10	5055750371	5055750370	5055750381	5055750380	3
6.53	2	8	5055750271	5055750270	5055750281	5055750280	2
			発注番号 ORDER NO.				極数 CIRCUIT SIZE
			キャリアテープ梱包 PACKAGING STYLE : CARRIER TAPE AND REEL				

① TABLE 1

番号 No.	部品 PART	材質 MATERIAL
①	ハウジング HOUSING	ポリアミド(PA), UL94 V-0, 色 : 注記6参照 POLYAMIDE(PA), UL94 V-0, COLOR: SEE NOTE6
②	ターミナル TERMINAL	黄銅 BRASS
		錫めっき : 1.0 micro-meter MINIMUM MATTE TIN PLATING
③	ネイル NAIL	リン青銅 PHOSPHOR BRONZE
		錫めっき : 1.0 micro-meter MINIMUM MATTE TIN PLATING
④	カバーテープ COVER TAPE	ニッケルめっき (下地) : 1.0 micro-meter MINIMUM NICKEL (UNDER PLATING) PLATING
		ポリイミド POLYIMIDE

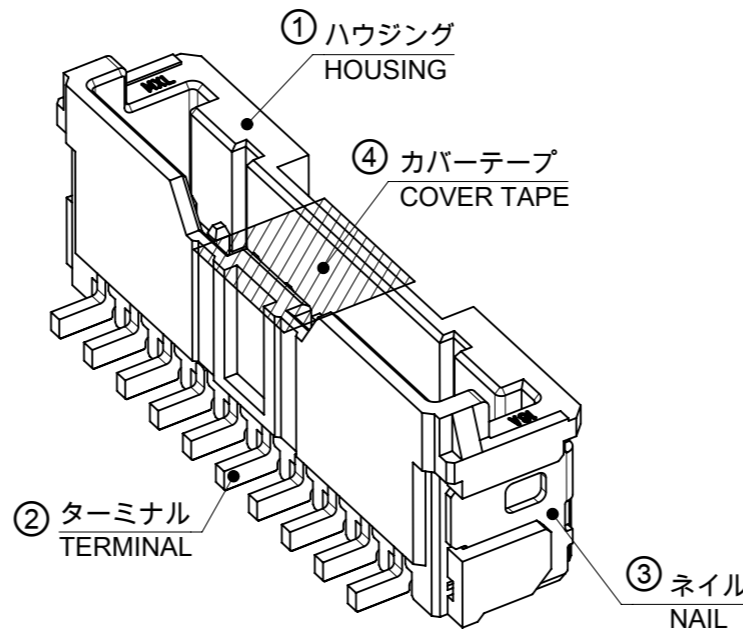

THIS DRAWING CONTAINS INFORMATION THAT IS PROPRIETARY TO MOLEX ELECTRONIC TECHNOLOGIES, LLC AND SHOULD NOT BE USED WITHOUT WRITTEN PERMISSION

DIMENSION UNITS mm	SCALE NTS	CURRENT REV DESC:		molex		
GENERAL TOLERANCES (UNLESS SPECIFIED)		EC NO: 624379				
ANGULAR TOL ± 3.0°	4 PLACES ± 0.2	DRWN: TENAGASE	2019/09/10	PRODUCT CUSTOMER DRAWING		
3 PLACES ± 0.2	2 PLACES ± 0.2	CHK'D: AIDA	2019/09/20	DOCUMENT NUMBER		
1 PLACE ± 0.2	0 PLACES ± 0.2	APPR: KOMURAKAMI	2019/09/20	5055750001		
DRAFT WHERE APPLICABLE MUST REMAIN WITHIN DIMENSIONS		THIRD ANGLE PROJECTION		DRWN: TENAGASE	2016/06/07	DOC TYPE
				APPR: TKANEKO	2016/06/23	DOC PART
				SERIES		REVISION
				A3-SIZE		000
				505575		C
				MATERIAL NUMBER		SHEET NUMBER
				CUSTOMER		1 OF 4
				GENERAL		

製品形状
PRODUCT SHAPE

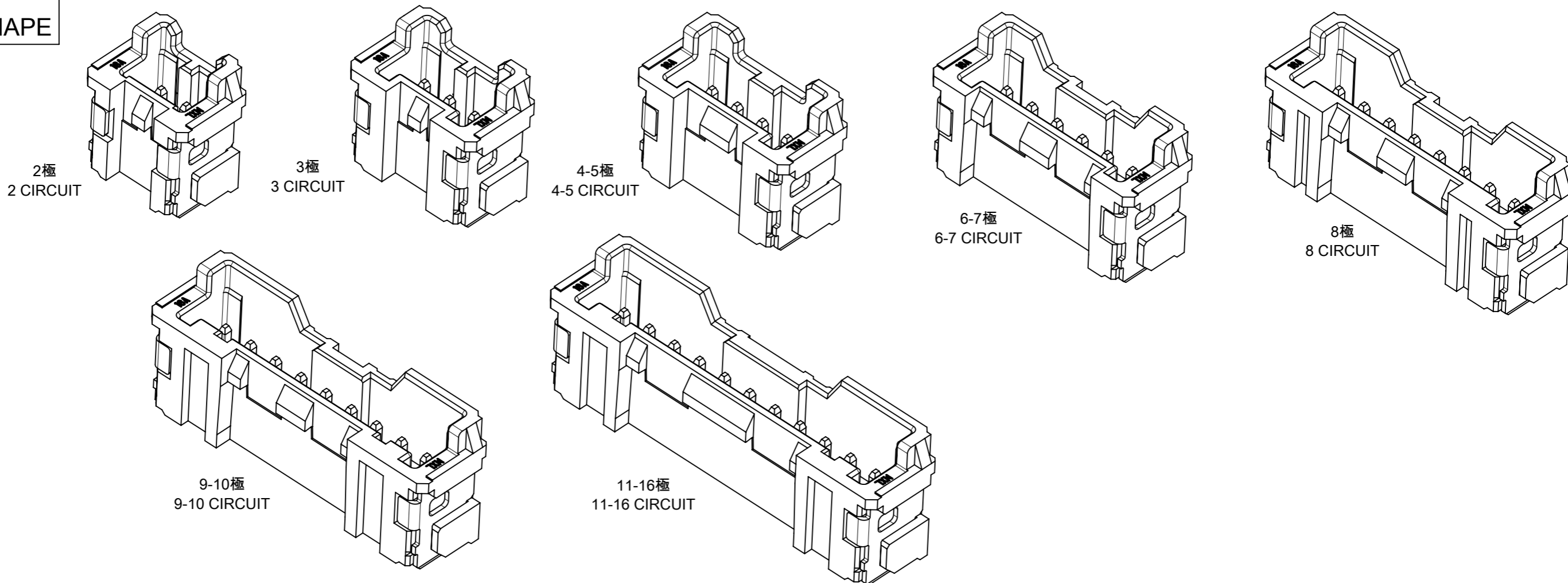

基板パターンレイアウト
PWB PATTERN LAYOUT

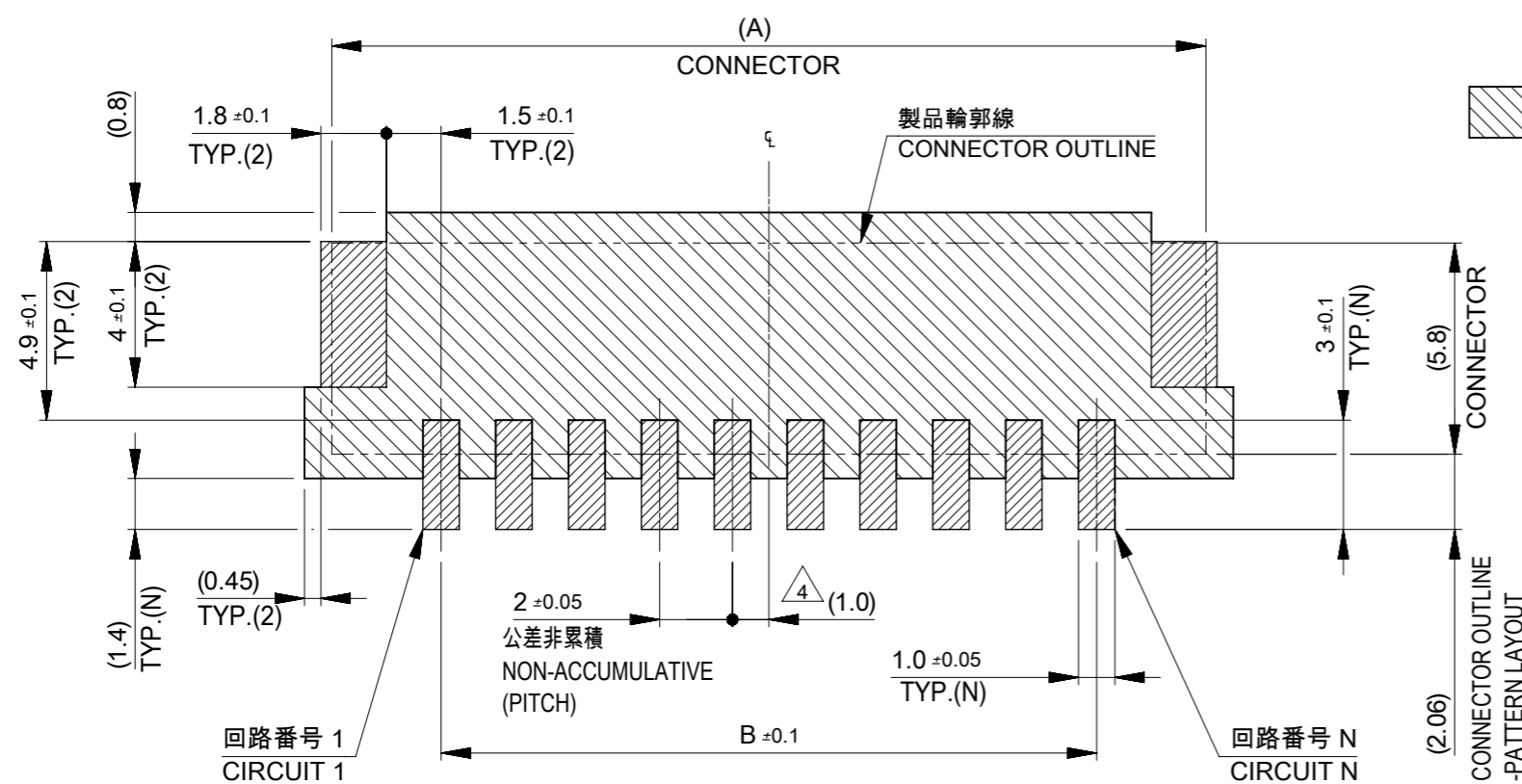

基板パターンレイアウト(参考)
(参考: 基板厚1.6mm, メタルマスク厚み0.15mm, マスク開口率100%)
PWB PATTERN LAYOUT (REFERENCE)
(REFERENCE: PWB THICKNESS 1.6mm, METAL MASK THICKNESS 0.15mm, APERTURE RATIO 100%)

パターン非推奨エリア
パターンを引き回す際には製品機能に影響がないことを御確認ください。
PATTERN IS NOT RECOMMENDED ON THE HATCHING AREA.
PLEASE CHECK NOT TO HAVE PROBLEM FOR PRODUCT FUNCTION
WHEN SETTING PATTERN ON THE HATCHING AREA.

THIS DRAWING CONTAINS INFORMATION THAT IS PROPRIETARY TO MOLEX ELECTRONIC TECHNOLOGIES, LLC AND SHOULD NOT BE USED WITHOUT WRITTEN PERMISSION		CURRENT REV DESC:		molex	
DIMENSION UNITS	SCALE				
mm	NTS			MICRO-LOCK PLUS 2.0W/B SINGLE ROW VERTICAL SMT PLUG ASSEMBLY	
GENERAL TOLERANCES (UNLESS SPECIFIED)		EC NO: 624379		DOCUMENT NUMBER	
ANGULAR TOL	± 3.0°	DRWN: TENAGASE	2019/09/10	5055750001	DOC TYPE
4 PLACES	± 0.2	CHK'D: AIDA	2019/09/20	PSD	DOC PART
3 PLACES	± 0.2	APPR: KOMURAKAMI	2019/09/20	000	REVISION
2 PLACES	± 0.2	INITIAL REVISION:		C	
1 PLACE	± 0.2	DRWN: TENAGASE	2016/06/07	SHEET NUMBER	
0 PLACES	± 0.2	APPR: TKANEKO	2016/06/23	2 OF 4	
DRAFT WHERE APPLICABLE MUST REMAIN WITHIN DIMENSIONS		THIRD ANGLE PROJECTION	DRAWING	SERIES	MATERIAL NUMBER
			A3-SIZE	505575	CUSTOMER
				GENERAL	

吸着エリア
VACUUM AREA

カバーテープ無
WITHOUT COVER TAPE
505575**7*

カバーテープ有
WITH COVER TAPE
505575**8*

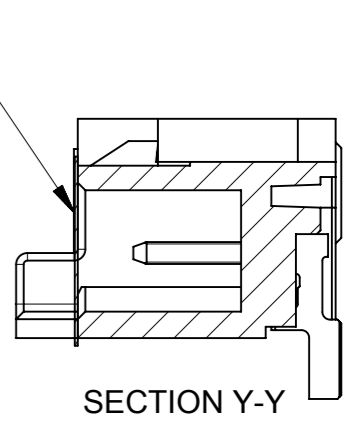
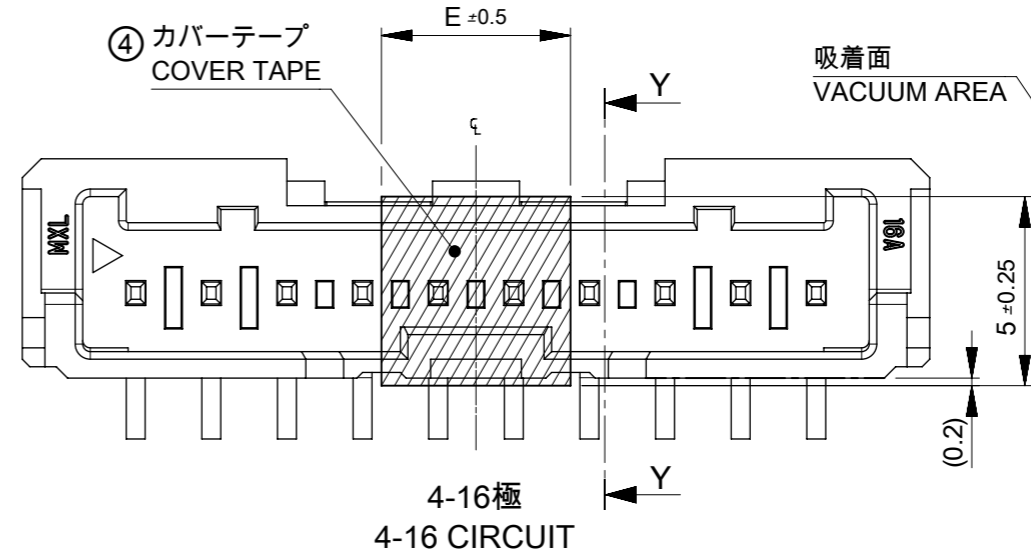
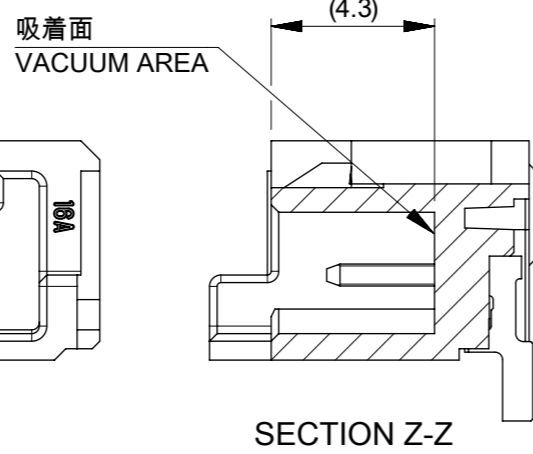
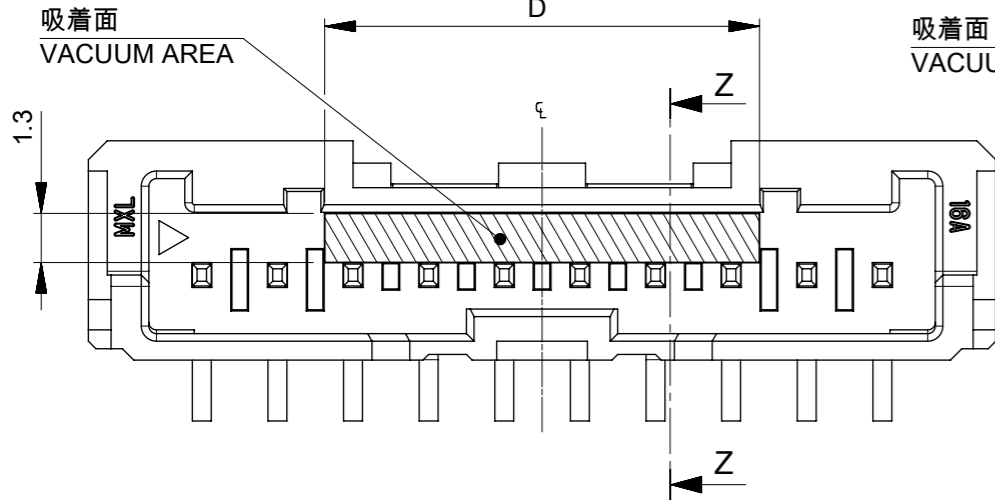

4-16極
4-16 CIRCUIT

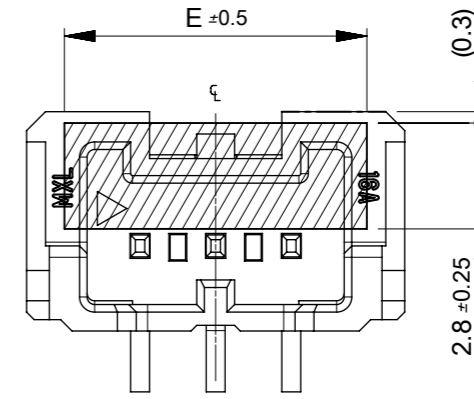

2-3極
2-3 CIRCUIT

嵌合状態図
MATED CONNECTORS

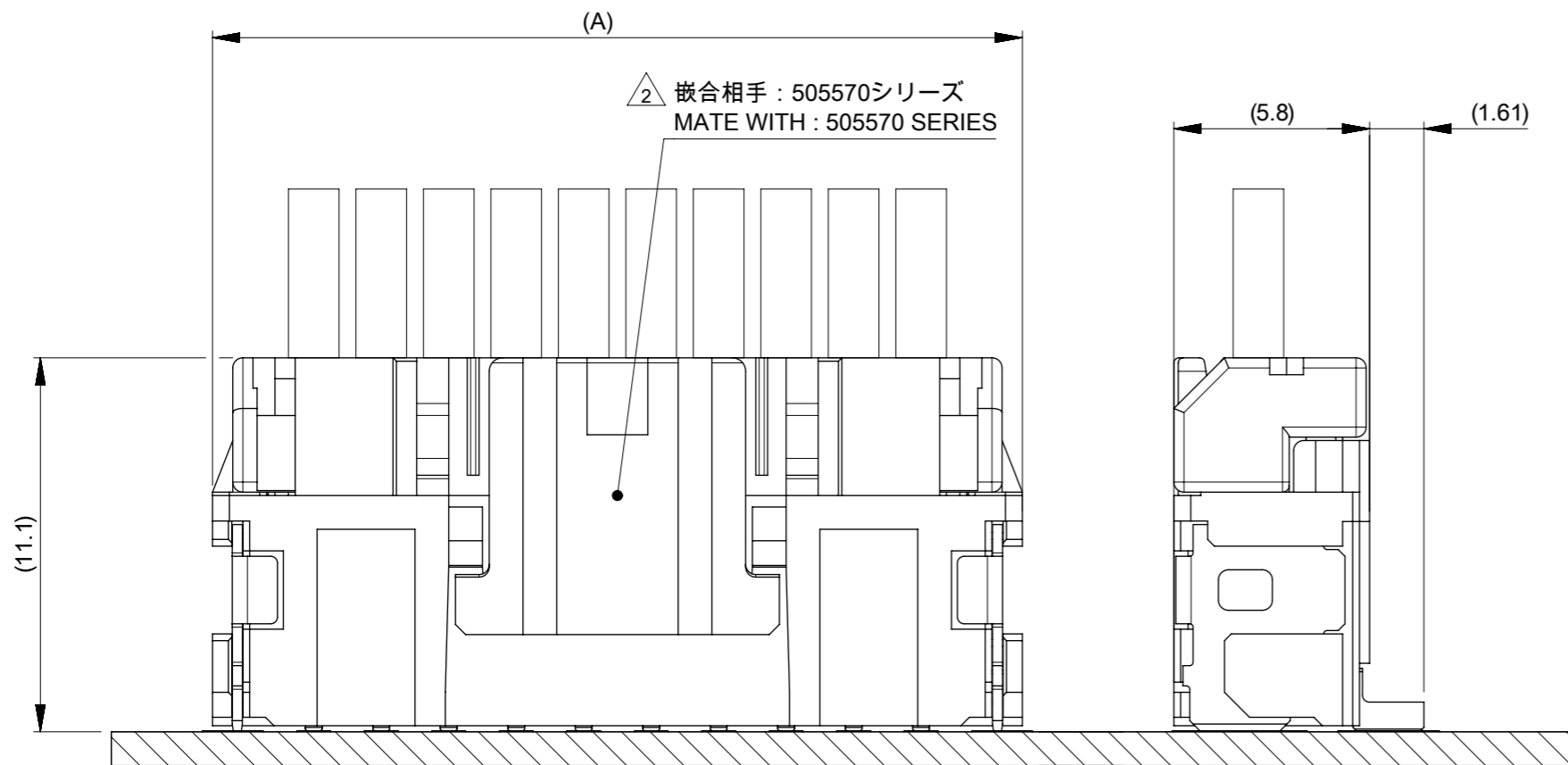

5	11.5	16
		15
4	9.5	14
		13
		12
		11
		10
		9
		8
		7
8	4.5	6
		5
		4
6	2.5	3
		2
E	D	極数 CIRCUIT SIZE

THIS DRAWING CONTAINS INFORMATION THAT IS PROPRIETARY TO MOLEX ELECTRONIC TECHNOLOGIES, LLC AND SHOULD NOT BE USED WITHOUT WRITTEN PERMISSION

DIMENSION UNITS mm	SCALE NTS	CURRENT REV DESC:		molex		
GENERAL TOLERANCES (UNLESS SPECIFIED)		EC NO: 624379				
ANGULAR TOL ± 3.0°	4 PLACES ± 0.2	DRWN: TENAGASE	2019/09/10	SINGLE ROW VERTICAL SMT PLUG ASSEMBLY		
3 PLACES ± 0.2	2 PLACES ± 0.2	CHK'D: AIDA	2019/09/20	PRODUCT CUSTOMER DRAWING		
1 PLACE ± 0.2	0 PLACES ± 0.2	APPR: KOMURAKAMI	2019/09/20	DOCUMENT NUMBER		
DRAFT WHERE APPLICABLE MUST REMAIN WITHIN DIMENSIONS		INITIAL REVISION:		5055750001		
THIRD ANGLE PROJECTION		DRWN: TENAGASE	2016/06/07	DOC TYPE	DOC PART	REVISION
DRAWING		APPR: TKANEKO	2016/06/23	PSD	000	C
SERIES		MATERIAL NUMBER		CUSTOMER		
A3-SIZE		505575		GENERAL		
SHEET NUMBER		3 OF 4				

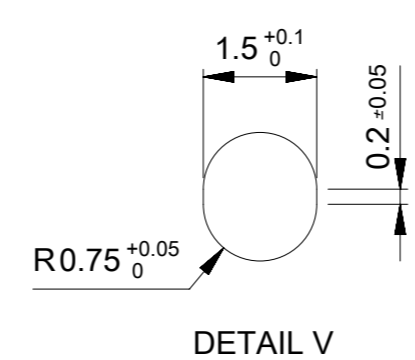
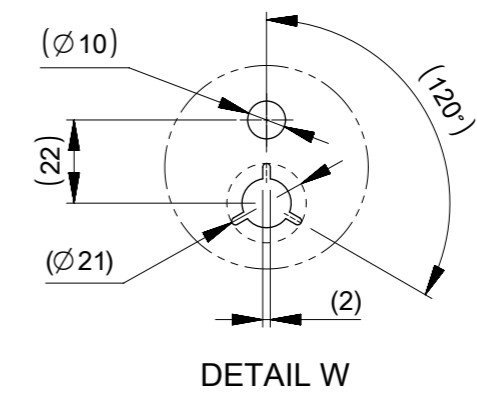
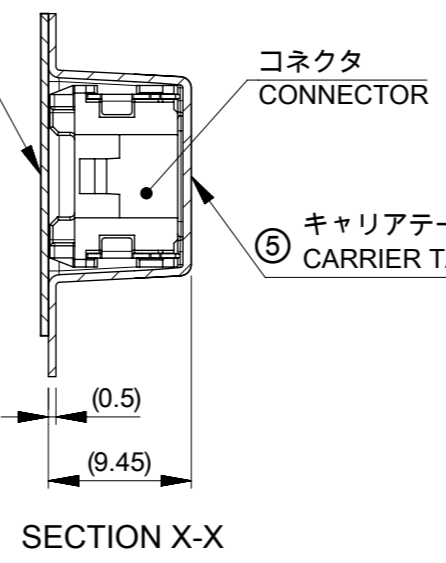
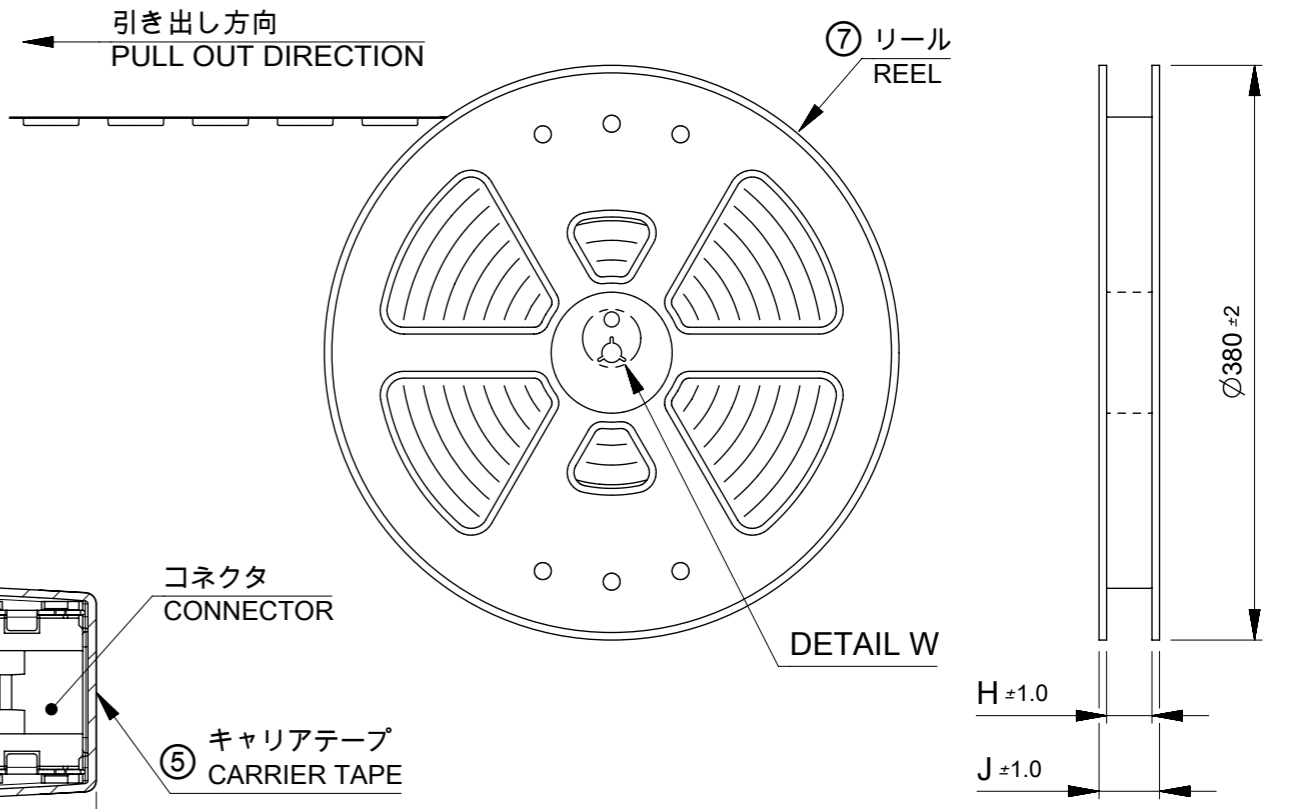
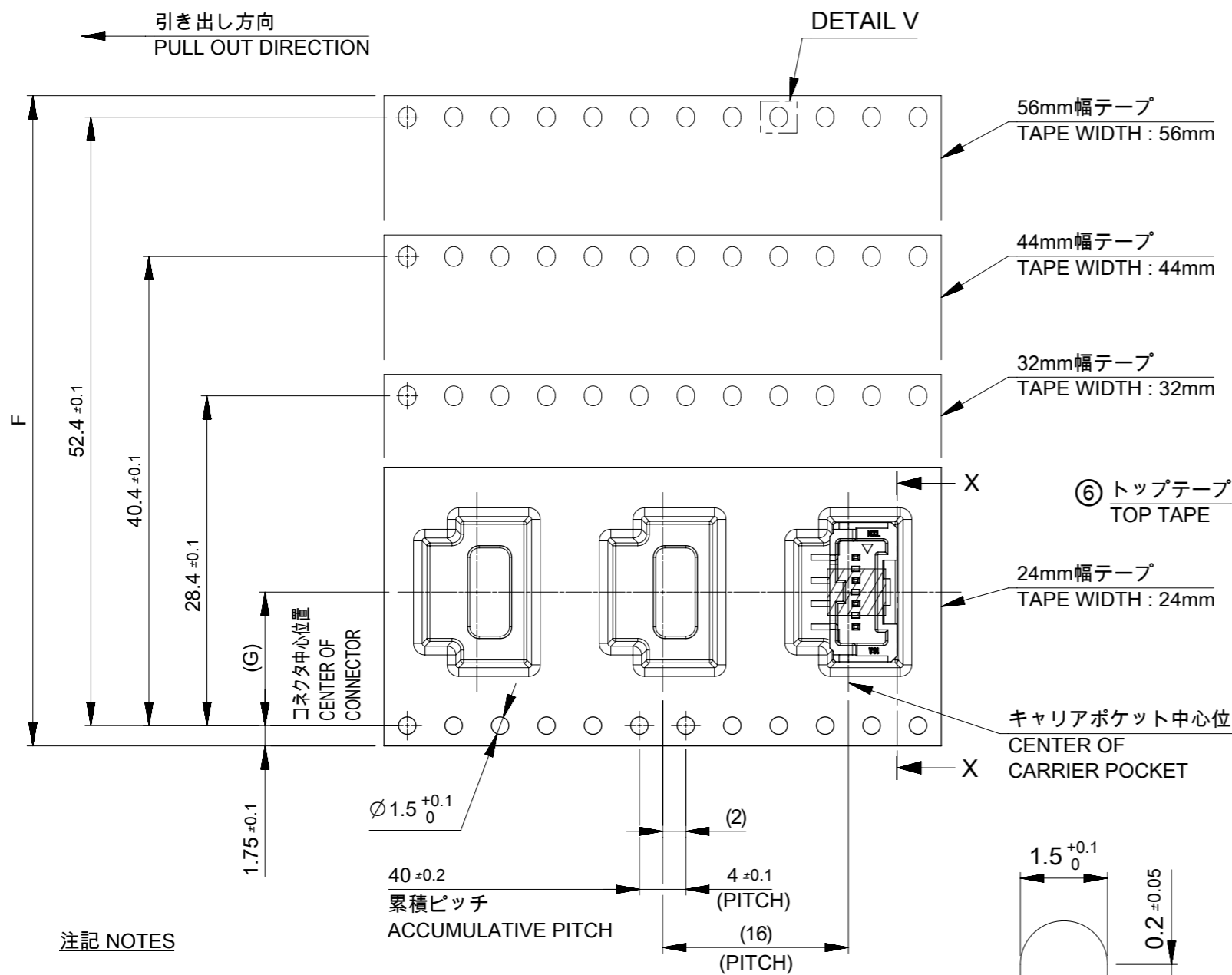

注記 NOTES

- 7. 梱包数量 : 600個
NUMBER OF CONNECTORS : 600 PIECES/REEL
- 8. 梱包仕様書 : 5055759200 PS 200
PACKING SPECIFICATION : 5055759200 PS 200
- 9. リードテープ長さ
LEAD TAPE LENGTH

10. トップテープの剥離強度については、IEC 60286-3に準拠
TOP TAPE PEEL FORCE IS DEFINED BY IEC 60286-3.

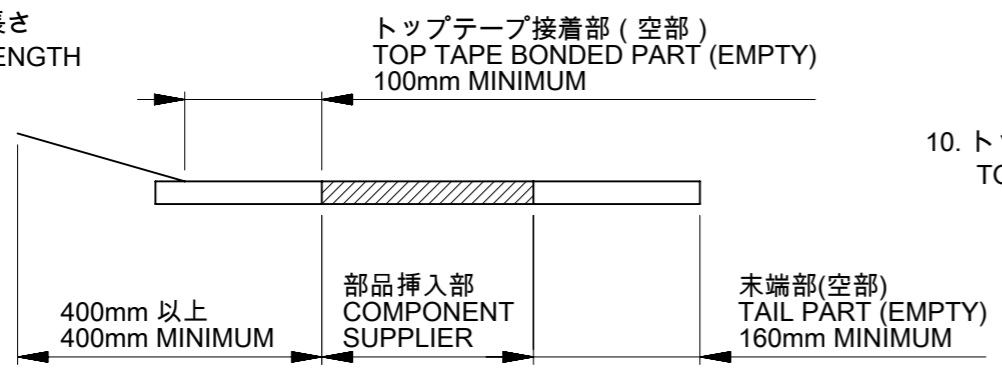

61.4	57.4	26.2	56±0.3	16
				15
				14
				13
				12
49.4	45.4	20.2	44±0.3	11
				10
				9
				8
37.4	33.4	14.2	32±0.3	7
				6
				5
				4
29.4	25.4	11.5	24 ±0.3 -0.1	3
				2
J	H	G	F	極数 CIRCUIT SIZE

TABLE 2

番号 No.	部品 PART	材質 MATERIAL
⑤	キャリアテープ CARRIER TAPE	ポリスチレン(PS) POLYSTYRENE(PS)
⑥	トップテープ TOP TAPE	ポリエチレン(PE), その他 POLYETHYLENE(PE), OTHER
⑦	リール REEL	ポリスチレン(PS), [リサイクル材を含む] POLYSTYRENE(PS) [RECYCLE MATERIAL CONTAINED]

THIS DRAWING CONTAINS INFORMATION THAT IS PROPRIETARY TO MOLEX ELECTRONIC TECHNOLOGIES, LLC AND SHOULD NOT BE USED WITHOUT WRITTEN PERMISSION

DIMENSION UNITS mm	SCALE NTS	CURRENT REV DESC:		molex		
GENERAL TOLERANCES (UNLESS SPECIFIED)		EC NO: 624379				
ANGULAR TOL	± 3.0°	DRWN: TENAGASE	2019/09/10	SINGLE ROW VERTICAL SMT PLUG ASSEMBLY		
4 PLACES	± 0.2	CHK'D: AIDA	2019/09/20	PRODUCT CUSTOMER DRAWING		
3 PLACES	± 0.2	APPR: KOMURAKAMI	2019/09/20	DOCUMENT NUMBER		
2 PLACES	± 0.2	INITIAL REVISION:		5055750001		
1 PLACE	± 0.2	DRWN: TENAGASE	2016/06/07	DOC TYPE	DOC PART	REVISION
0 PLACES	± 0.2	APPR: TKANEKO	2016/06/23	PSD	000	C
DRAFT WHERE APPLICABLE MUST REMAIN WITHIN DIMENSIONS		THIRD ANGLE PROJECTION	DRAWING	SERIES	MATERIAL NUMBER	CUSTOMER
			A3-SIZE	505575	GENERAL	SHEET NUMBER
						4 OF 4