

NOTES:

- MATERIAL:
 - HOUSING: HIGH TEMPERATURE THERMOPLASTIC, 30% GLASS FILLED, BLACK, UL94V-0.
 - TAIL GUIDER: HIGH TEMPERATURE THERMOPLASTIC, 30% GLASS FILLED, BLACK, UL94V-0.
 - TERMINAL-1: COPPER ALLOY.
 - TERMINAL-2: COPPER ALLOY.
 - METAL SHELL: STAINLESS STEEL.
- TERMINAL PLATING:
 - CONTACT AREA: GOLD PLATING. SEE TABLE
 - SOLDER AREA: MATTE TIN PLATING, 2.0 MICROMETERS MINIMUM.
 - UNDER PLATING: NICKEL PLATING, 2.0 MICROMETERS MINIMUM.
- METAL SHELL PLATING: SOLDERABLE NICKEL PLATING.
- PRODUCT SPECIFICATION: PS-47403-001.
- PACKAGE SPECIFICATION: PK-105124-001.
- PRODUCT COMPLIANT TO RoSH DIRECTIVE 2002/95/EC AND ELV DIRECTIVE 2000/53/EC.

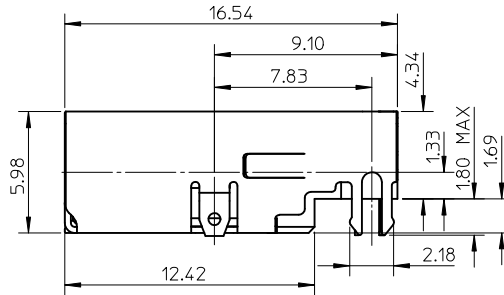
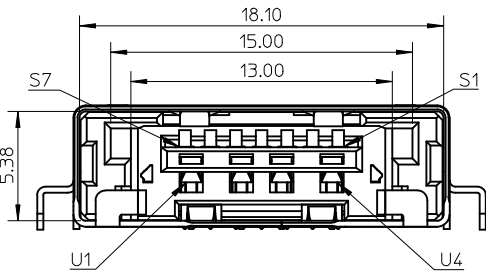

PIN ASSIGNMENT

USB		ESATA	
NAME	TYPE	NAME	TYPE
U1	VBUS	S1	GND
U2	D-	S2	A+
U3	D+	S3	A-
U4	GND	S4	GND
		S5	B-
		S6	B+
		S7	GND

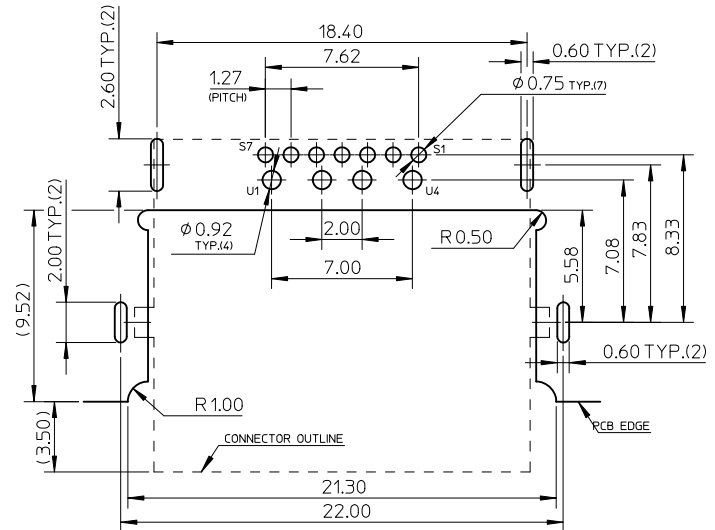

RECOMMEND PCB LAYOUT T=1.40
PCB TOLERANCE = ±0.05

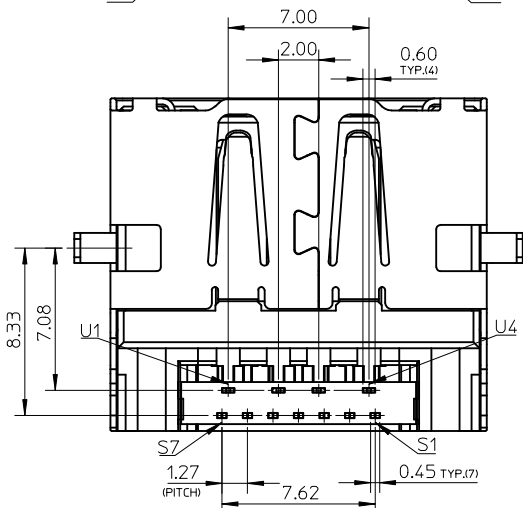

P/N	GOLD PLATING SPEC
105124-1000	GOLD FLASH
105124-1001	15u" MINIMUM
105124-1002	30u" MINIMUM

<p>NEW RELEASE EC NO: SH2010-0293 DRAWING: 2010/01/20 CHKD: STARY SONG 2009/08/05 APPR: RZHANG 2010/06/02</p>	<p>QUALITY SYMBOLS F=0 E=0 E=0</p>	<p>GENERAL TOLERANCES (UNLESS SPECIFIED)</p> <table border="1"> <thead> <tr> <th></th> <th>mm</th> <th>INCH</th> </tr> </thead> <tbody> <tr> <td>4 PLACES</td> <td>±---</td> <td>±---</td> </tr> <tr> <td>3 PLACES</td> <td>±---</td> <td>±---</td> </tr> <tr> <td>2 PLACES</td> <td>±0.25</td> <td>±---</td> </tr> <tr> <td>1 PLACE</td> <td>±0.25</td> <td>±---</td> </tr> </tbody> </table>			mm	INCH	4 PLACES	±---	±---	3 PLACES	±---	±---	2 PLACES	±0.25	±---	1 PLACE	±0.25	±---	<p>DIMENSION STYLE MM ONLY</p>	<p>SCALE 4:1</p>	<p>DESIGN UNITS METRIC</p>	<p>THIRD ANGLE PROJECTION</p>
			mm	INCH																		
		4 PLACES	±---	±---																		
		3 PLACES	±---	±---																		
2 PLACES	±0.25	±---																				
1 PLACE	±0.25	±---																				
<p>DRAFT WHERE APPLICABLE MUST REMAIN WITHIN DIMENSIONS</p>		<p>DRAWN BY: DIXON LI CHECKED BY: STARY SONG APPROVED BY: ROST ZHANG</p>	<p>DATE: 2009/08/05 DATE: 2009/08/05 DATE: 2009/08/05</p>	<p>TITLE COMBO OF ESATA & USB TOP MOUNT, SINK TYPE</p>																		
<p>SIZE A3</p>		<p>SEE CHART</p>			<p>MOLEX INCORPORATED</p>		<p>SHEET NO. 1 OF 1</p>															
<p>THIS DRAWING CONTAINS INFORMATION THAT IS PROPRIETARY TO MOLEX INCORPORATED AND SHOULD NOT BE USED WITHOUT WRITTEN PERMISSION</p>							<p>DOCUMENT NO. SD-105124-100</p>															