

REVISIONS					
P	LTR	DESCRIPTION	DATE	DWN	APVD
E1		REVISED PER ECN-22-150900	22APR2022	RK	CSD

**METRIC**  
DIMENSIONS LISTED IN mm [ INCHES ]

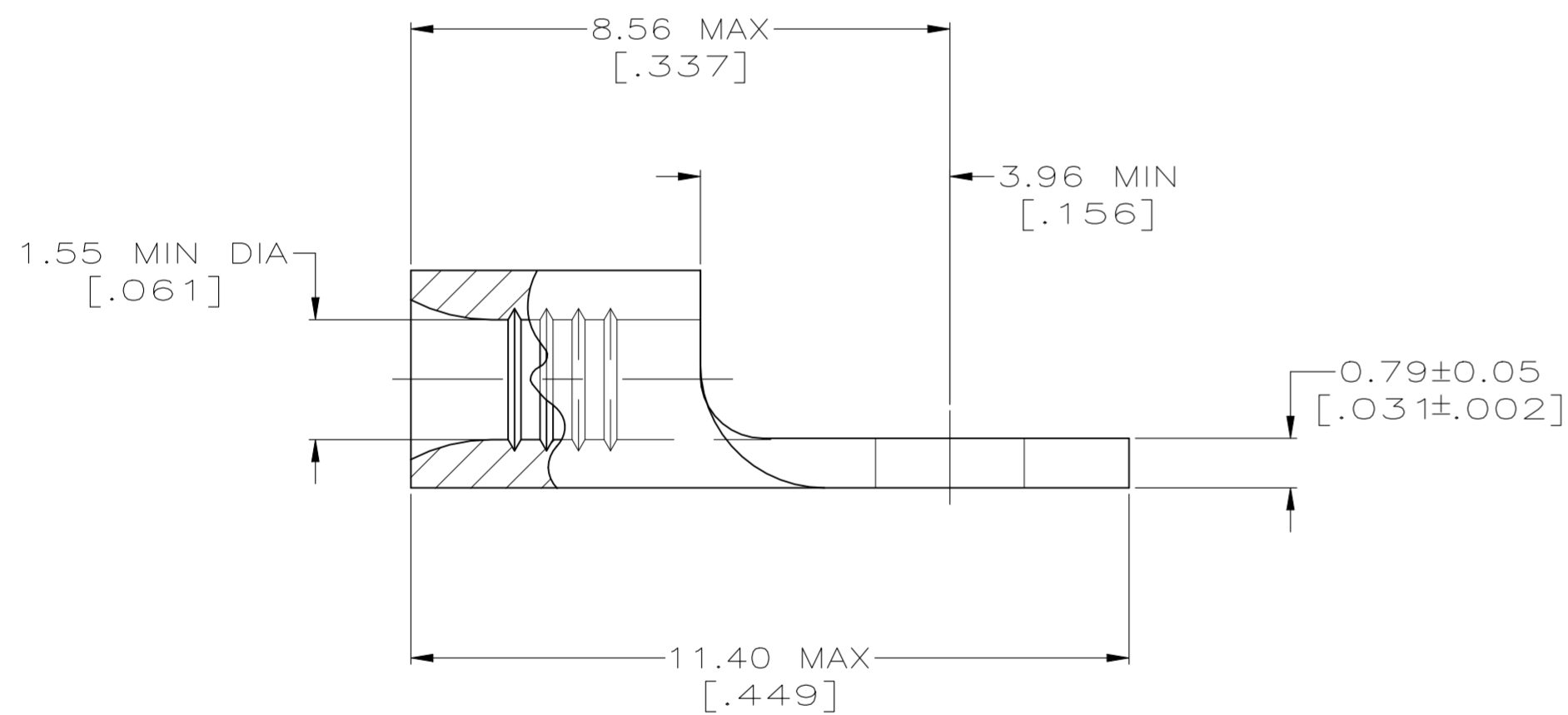
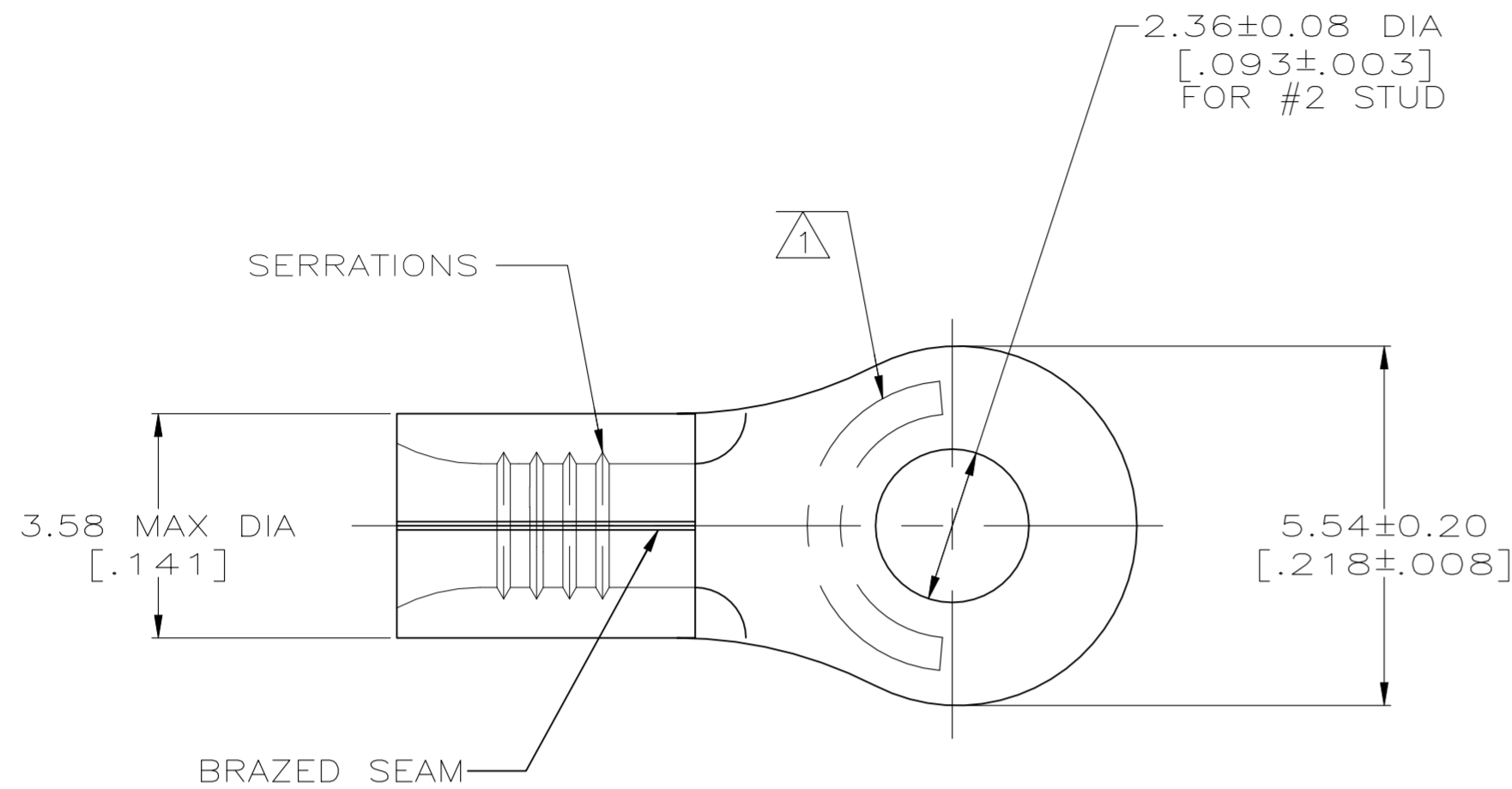

<b>AMP</b> WIRE RANGE	E13288 Listed
22-16 AWG SOLID OR STRANDED	22-16 AWG SOLID OR STRANDED

LR7189 Certified
22-16 AWG SOLID OR STRANDED

1 STAMP AMP 22-18\* APPROX AS SHOWN  
22-16 TERMINALS ARE STAMPED 22-18 IN  
ACCORDANCE WITH MILITARY SPECIFICATION  
MIL-T-7928; COMMERCIAL WIRE RANGE IS 22-16

5000	ON TAPE	2-34103-1
----	LOOSE PIECE	34103
QUANTITY	PACKAGING TYPE	PART NO

<b>AMP INCORPORATED CUSTOMER SERVICE SYSTEMS</b>		MAX RECOMMENDED OPERATING TEMPERATURE: 170° C MAX
FOR ADDITIONAL PRODUCT INFORMATION OR COPIES OF DRAWINGS AND TECHNICAL DOCUMENTS	PRODUCT INFORMATION CENTER 1-800-522-6752	VOLTAGE RATING: NOT APPLICABLE
FOR APPLICATION TOOLING INFORMATION	TOOLING ASSISTANCE CENTER 1-800-722-1111	WIRE CROSS SECTIONAL AREA RANGE: 0.26-1.65mm <sup>2</sup> [509-3,260] CIR MILS SOLID OR STRANDED
FOR ORDER ENTRY	1-800-526-5142	THIS DRAWING IS A CONTROLLED DOCUMENT FOR AMP INCORPORATED. IT IS SUBJECT TO CHANGE AND THE CONTROLLING ENGINEERING ORGANIZATION SHOULD BE CONTACTED FOR THE LATEST REVISION.

THIS DRAWING IS A CONTROLLED DOCUMENT.		DWN TA BRINKMAN 1-27-93	TE Connectivity	
DIMENSIONS: mm[INCHES]		CHK DA PATTERSON 1-27-93		
TOLERANCES UNLESS OTHERWISE SPECIFIED:		APVD DE MILLER 1-27-93	NAME TERMINAL, RING TONGUE, SOLISTRAND TM	
0 PLC ± - 1 PLC ± - 2 PLC ± - 3 PLC ± - 4 PLC ± - ANGLES ± -		PRODUCT SPEC -	SIZE A2	
MATERIAL COPPER PER ASTM B-152 ANNEALED		FINISH TIN PLATE 0.00254[.000100] MIN THK PER MIL-T-10727	APPLICATION SPEC -	CAGE CODE 00779
		WEIGHT -	DRAWING NO C-34103	RESTRICTED TO -
		CUSTOMER DRAWING	SCALE 10:1	SHEET 1 of 1
			REV E1	