

## Predefined gesture detection system based on FlightSense technology sensors



### Features

- CAN bus interface for remote control support
- Serial interface for remote communication support
- Input voltage: 12 V battery bus
- Size: 250 mm x 86 mm
- Included in the [AutoDevKit](#) ecosystem

### Description

The [AEK-SNS-2TOFM1](#) includes two Time-of-Flight distance-ranging sensors placed at a distance of 23 cm one from the other.

The on-board [SPC582B60E1](#) microcontroller reads the sensor data and detects a predefined hand/foot gesture.

This solution is designed for power liftgate applications, to open/close the trunk with a predefined foot movement.

The [AEK-SNS-2TOFM1](#) evaluation board firmware is preloaded. It is enabled for an external CAN bus driving.

The [AutoDevKit](#) software library ([STSW-AUTODEVKIT](#)) includes a CAN bus-driving example based on the [SPC58EC Chorus 4M](#).

Product summary	
Predefined gesture detection system based on FlightSense technology sensors	<a href="#">AEK-SNS-2TOFM1</a>
32-bit power architecture MCU for automotive general purpose applications - Chorus family	<a href="#">SPC582B60E1MH00Y</a>
AutoDevKit library plugin for SPC5-STUDIO	<a href="#">STSW-AUTODEVKIT</a>
Code generator, quick resource configurator and Eclipse development environment for SPC5 MCUs	<a href="#">SPC5-Studio</a>
Application	<a href="#">Trunk Control System/</a> <a href="#">Motion Sensing/</a> <a href="#">Presence Sensing</a>

# 1 Block diagram

Figure 1. AEK-SNS-2TOFM1 block diagram

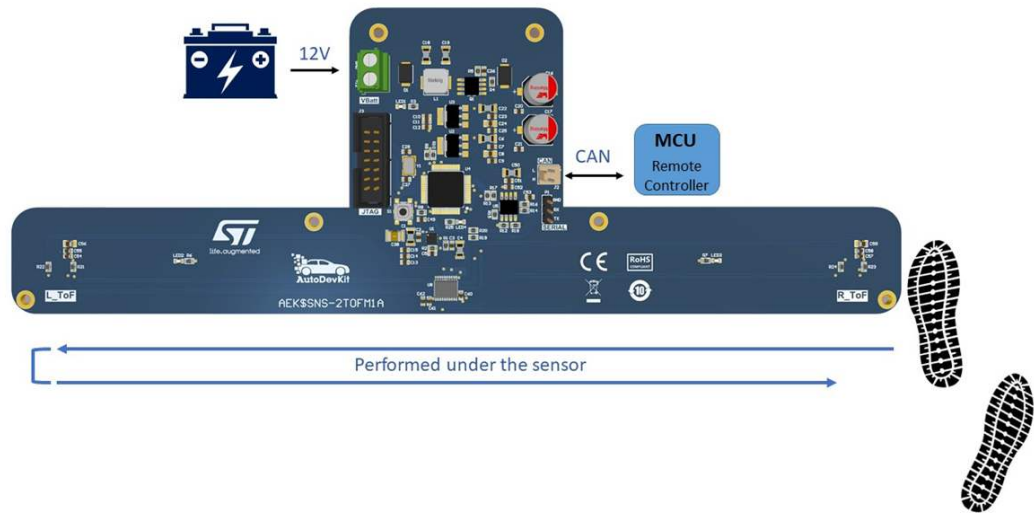

## 2 Schematic diagrams

Figure 2. AEK-SNS-2TOFM1 circuit schematic (1 of 5)

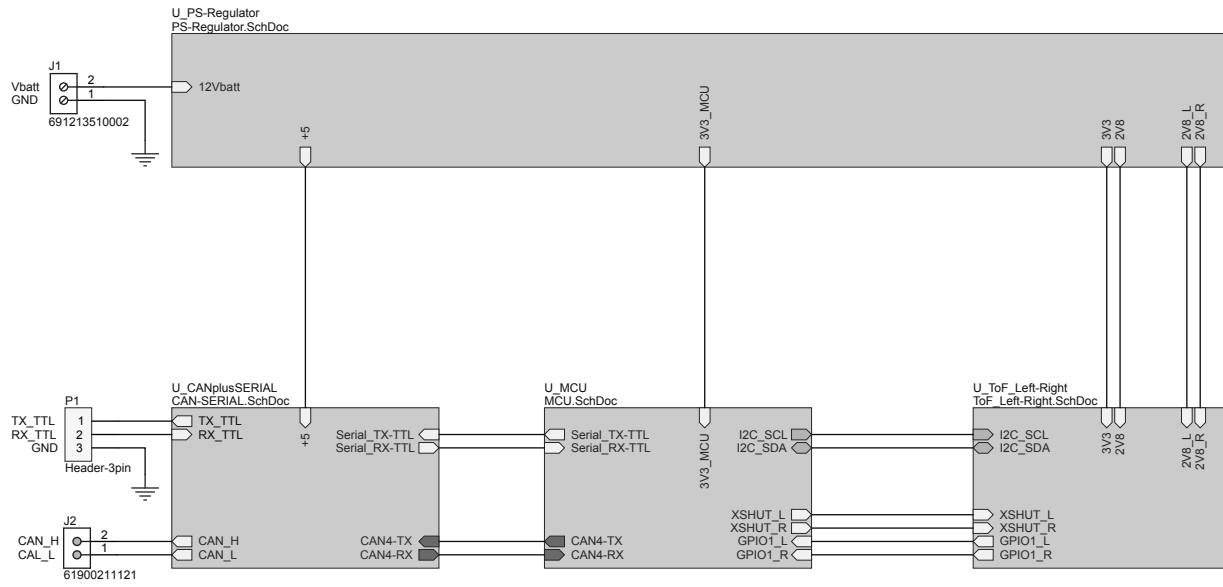

Figure 3. AEK-SNS-2TOFM1 circuit schematic (2 of 5)

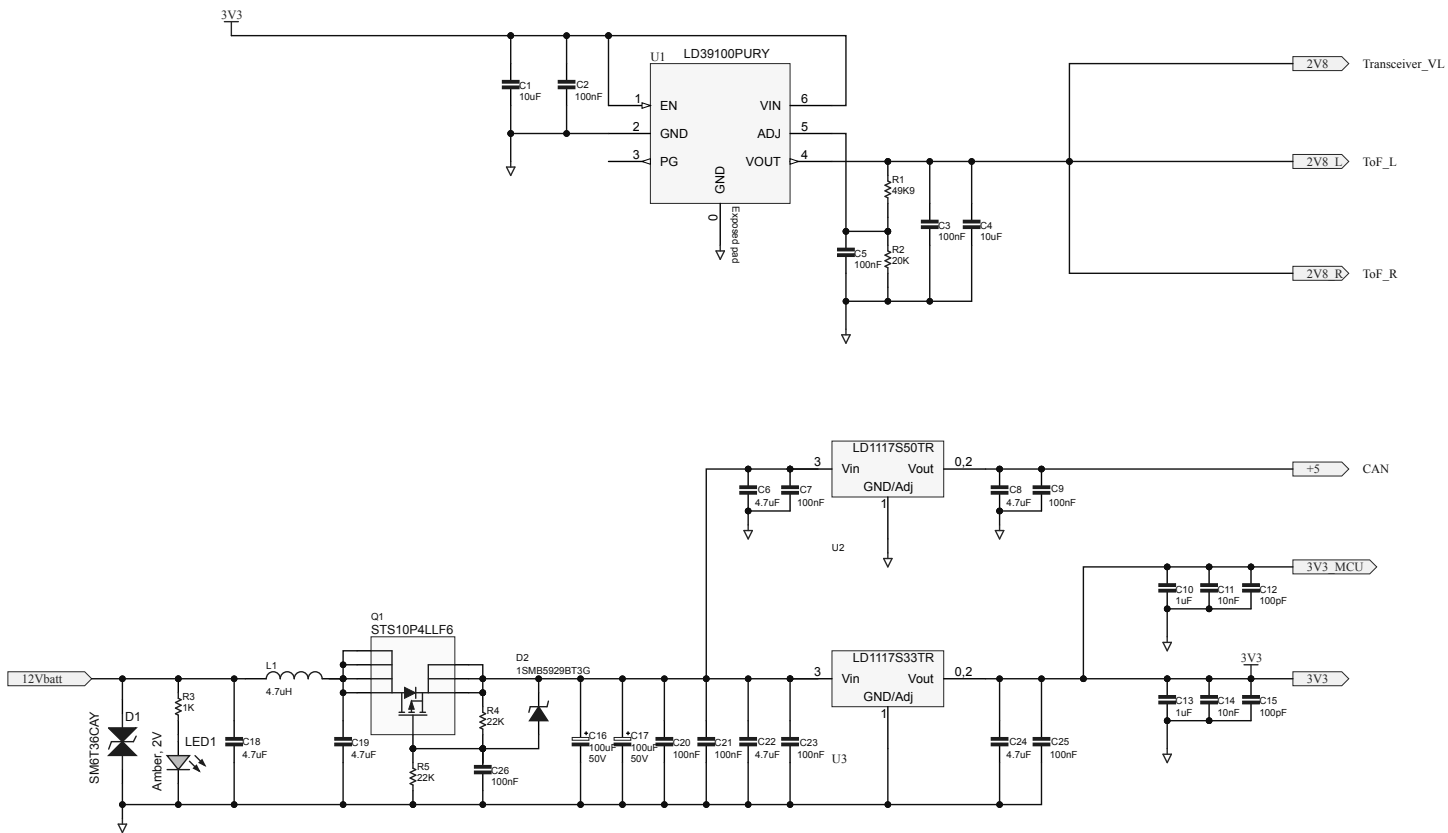

Figure 4. AEK-SNS-2TOFM1 circuit schematic (3 of 5)

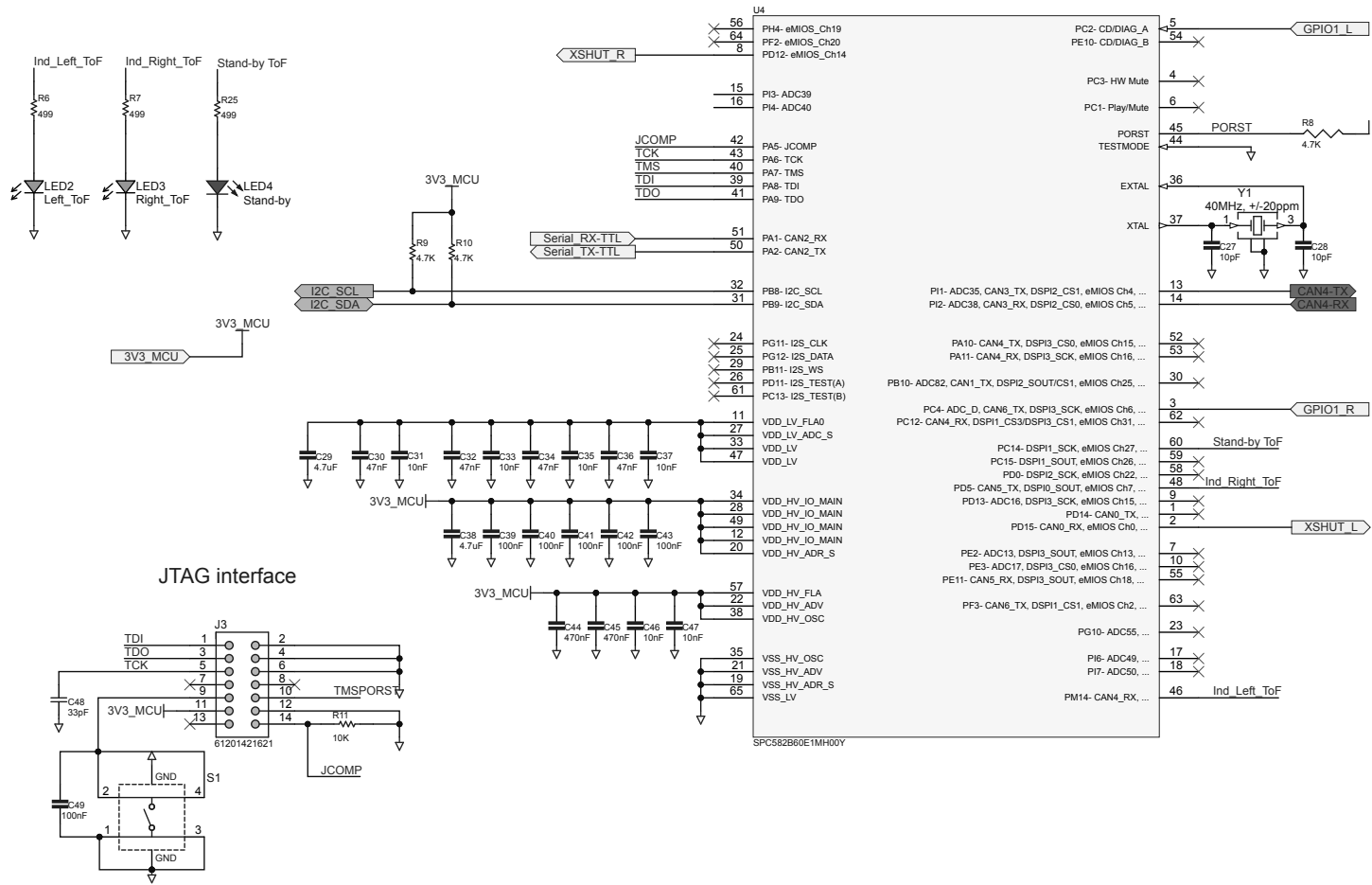

Figure 5. AEK-SNS-2TOFM1 circuit schematic (4 of 5)

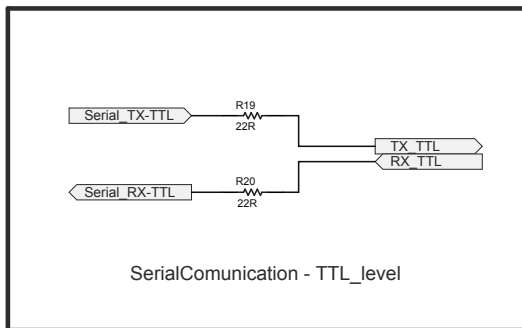
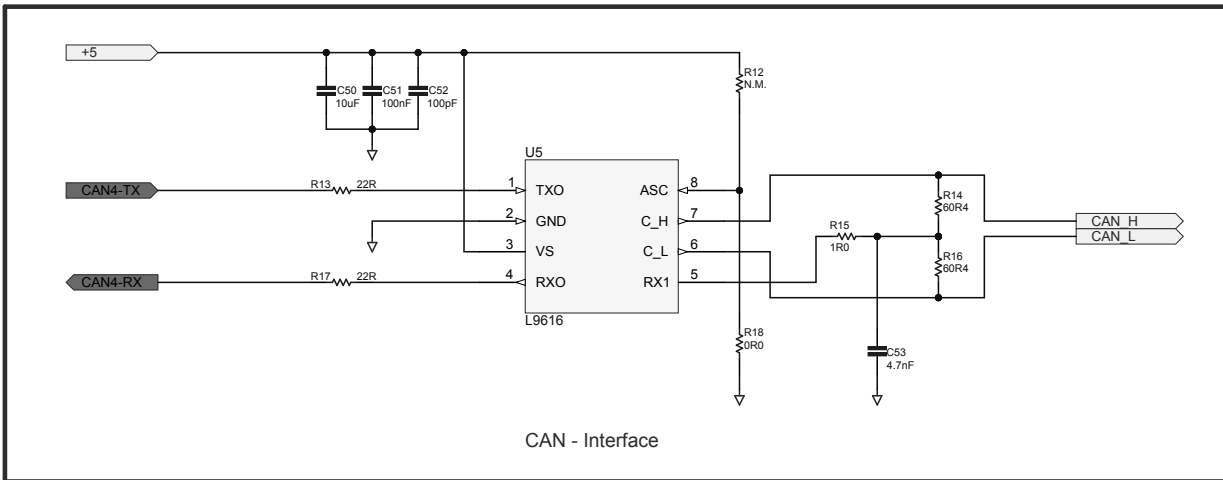
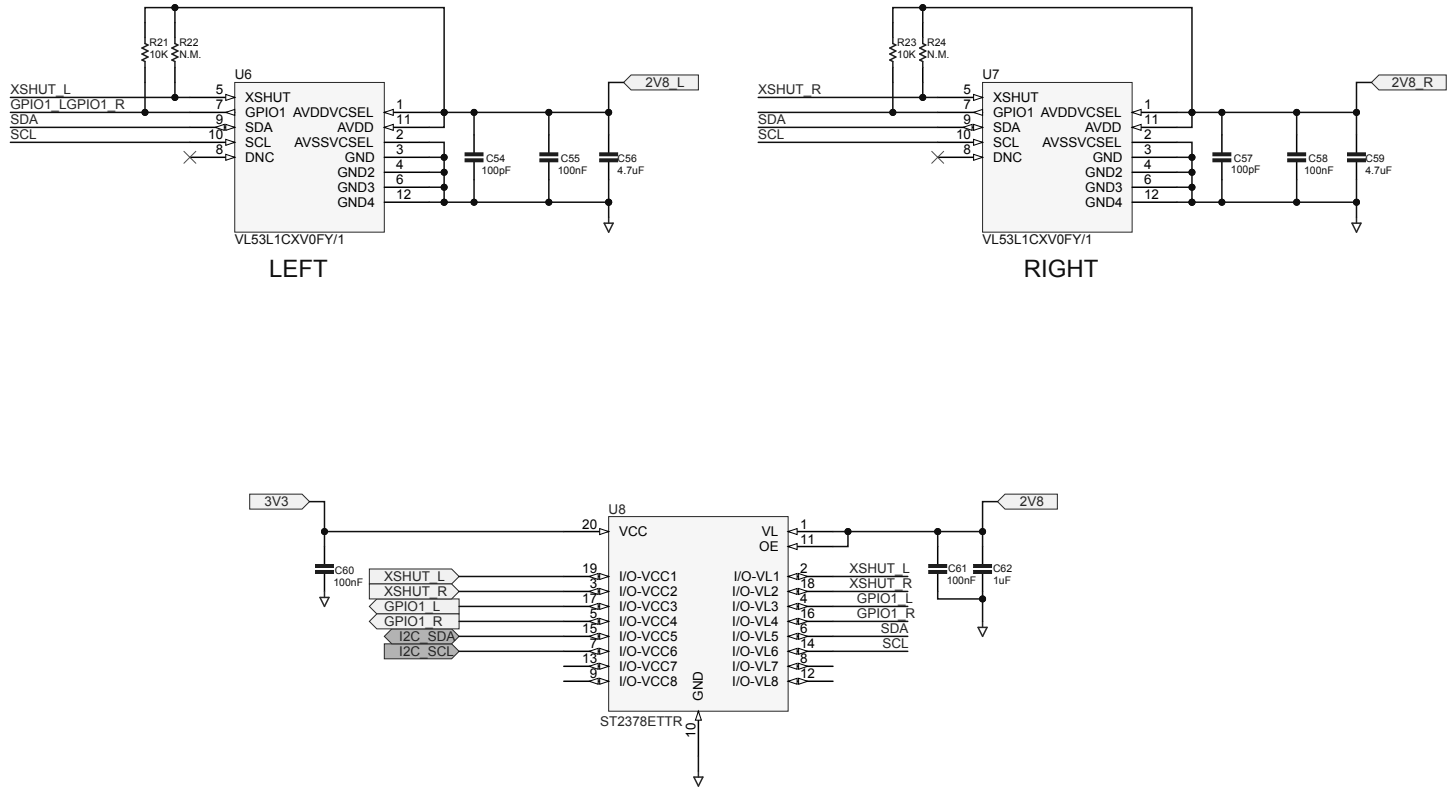

Figure 6. AEK-SNS-2TOFM1 circuit schematic (5 of 5)



### 3 Board versions

**Table 1. AEK-SNS-2TOFM1 versions**

PCB version	Schematic diagrams	Bill of materials
AEK\$SNS-2TOFM1A <sup>(1)</sup>	AEK\$SNS-2TOFM1A schematic diagrams	AEK\$SNS-2TOFM1A bill of materials

1. This code identifies the AEK-SNS-2TOFM1 evaluation board first version. It is printed on the board PCB.



## Revision history

**Table 2. Document revision history**

Date	Revision	Changes
24-May-2022	1	Initial release.

**IMPORTANT NOTICE – READ CAREFULLY**

STMicroelectronics NV and its subsidiaries (“ST”) reserve the right to make changes, corrections, enhancements, modifications, and improvements to ST products and/or to this document at any time without notice. Purchasers should obtain the latest relevant information on ST products before placing orders. ST products are sold pursuant to ST’s terms and conditions of sale in place at the time of order acknowledgment.

Purchasers are solely responsible for the choice, selection, and use of ST products and ST assumes no liability for application assistance or the design of purchasers’ products.

No license, express or implied, to any intellectual property right is granted by ST herein.

Resale of ST products with provisions different from the information set forth herein shall void any warranty granted by ST for such product.

ST and the ST logo are trademarks of ST. For additional information about ST trademarks, refer to [www.st.com/trademarks](http://www.st.com/trademarks). All other product or service names are the property of their respective owners.

Information in this document supersedes and replaces information previously supplied in any prior versions of this document.

© 2022 STMicroelectronics – All rights reserved