

SPECIFICATIONS

PARAMETERS	VALUES	UNITS
RATED INPUT POWER	1	W
MAX INPUT POWER	1.5	W
IMPEDANCE	8 ± 15%	OHM
OUTPUT SPL @ 1W/1M (AT 0.6, 0.8, 1.0, 1.2 kHz)	83 ± 3	dB
DISTORTION (MAX.)	5%	-
RESONANT FREQUENCY	450 ± 20%	Hz
FREQUENCY RANGE	450 ~ 6000	Hz
HOUSING MATERIAL	METAL	-
CONE MATERIAL	MYLAR	-
MAGNET MATERIAL	N35	-
OPERATING TEMPERATURE	-20 ~ +60	°C
STORAGE TEMPERATURE	-30 ~ +60	°C
WEIGHT	9	grams

THIS DOCUMENT CONTAINS DATA PROPRIETARY TO PROJECTS UNLIMITED, INC. ANY USE OR REPRODUCTION, IN ANY FORM, WITHOUT PRIOR WRITTEN PERMISSION OF PROJECTS UNLIMITED, INC. IS PROHIBITED.
©2003, Projects Unlimited Inc.

REVISION HISTORY

LTR	DESCRIPTION	DATE	APPROVED
-	RELEASED FROM ENGINEERING	2/20/2006	
A	ADDED STORAGE TEMPERATURE	2/26/2009	B.R.
B	REVISED TO INENTOR 3-D DRAWING TEMPLATE	5/23/2009	B.R.
C	REVISED SPL AND WEIGHT	11/1/2013	M.L.

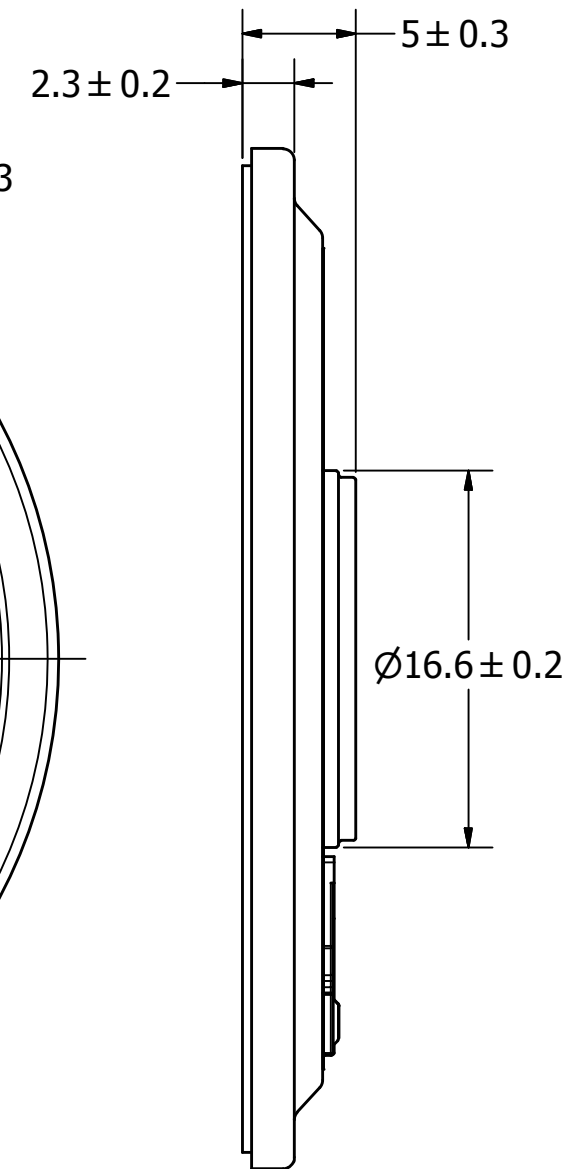
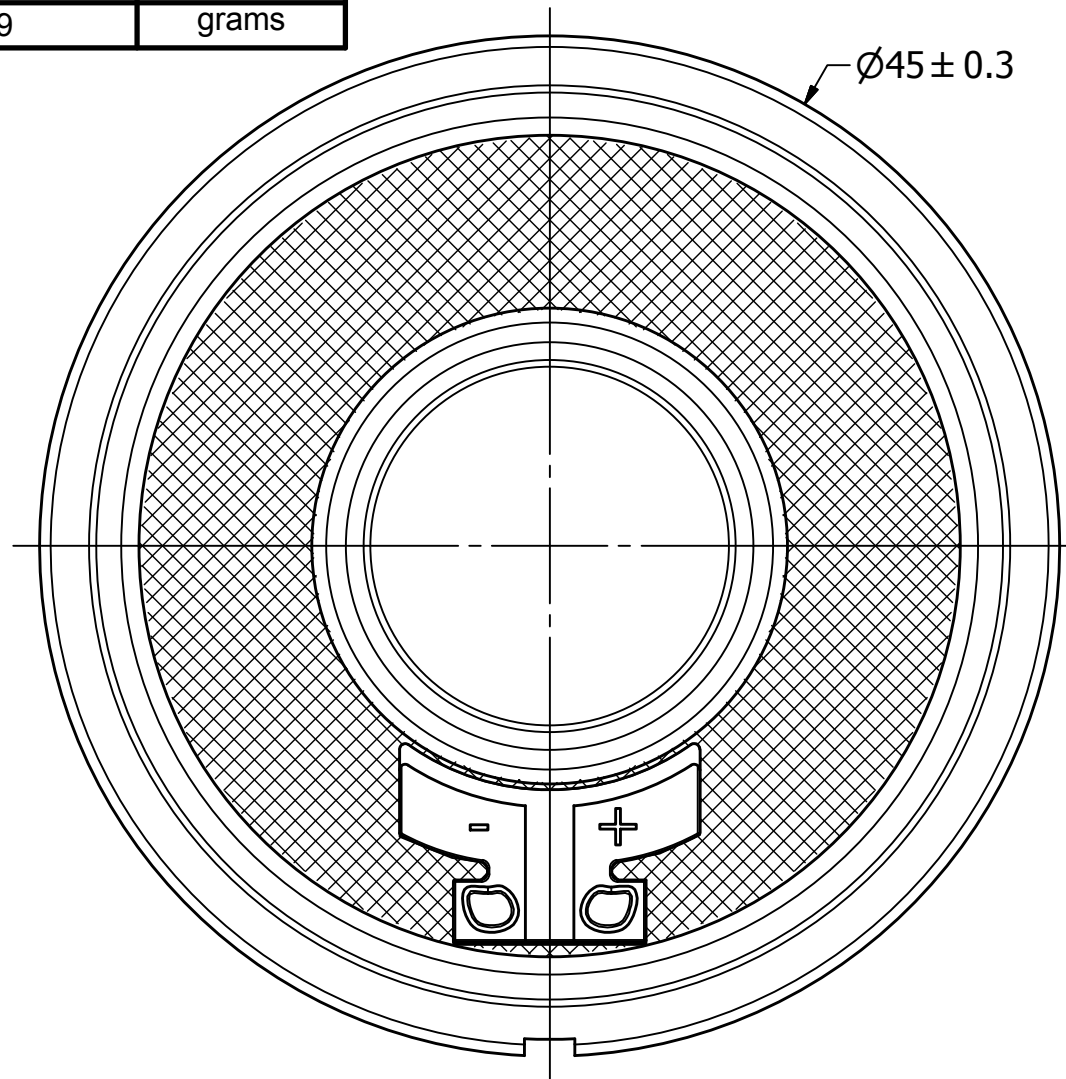

NOTES:

1. ALL DIMENSIONS ARE IN MILLIMETERS.
2. SPECIFICATIONS SUBJECT TO CHANGE OR WITHDRAWL WITHOUT NOTICE.
3. THIS PART IS RoHS 2011/65/EU COMPLIANT.

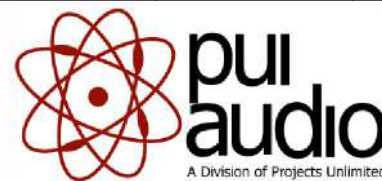
UNLESS OTHERWISE SPECIFIED: DIMENSIONS ARE IN MILLIMETERS, TOLERANCES ARE ±0.5 AND ANGLES ARE ±3°.	SIZE A3	Designed by	Date	Checked by	Date	Approved by	Date	Drawn Date
		J.A.F.	2/20/2006	E.P.	2/20/2006	B.R.	2/20/2006	5/23/2009
AS04508MR-3-R.idw				AS04508MR-3-R Speaker		Edition	Sheet	
						-	1 / 1	