

# TLE2662

## DUAL $\mu$ POWER JFET-INPUT OPERATIONAL AMPLIFIER WITH SWITCHED-CAPACITOR VOLTAGE CONVERTER

SLOS118B – DECEMBER 1992 – REVISED AUGUST 1994

- Single-Supply Operation With Rail-to-Rail Inputs
- $V_{OL} = 0.000\text{ V}$  While Sinking 25 mA
- Wide  $V_{CC}$  Range . . . 3.5 V to 15 V
- SCOUT Supplies up to 100 mA for External Loads
- Shutdown Mode
- External 2.5-V Voltage Reference Available

### description

The TLE2662 offers the advantages of JFET-input operational amplifiers and rail-to-rail common-mode input voltage range with the convenience of single-supply operation. By combining a switched-capacitor voltage converter with a dual operational amplifier in a single package, Texas Instruments now gives circuit designers new options for conditioning low-level signals in single-supply systems.

The TLE2662 features two low power, high-output drive JFET-input operational amplifiers with a switched-capacitor building block. Using two external capacitors, the switched-capacitor network can be configured as a voltage inverter, generating a negative supply voltage capable of sourcing up to 100 mA. This supply functions not only as the amplifier negative rail but is also available to drive external circuitry. In this configuration, the amplifier common-mode input voltage range extends from the positive rail to below ground, providing true rail-to-rail inputs from a single supply. Furthermore, the outputs can swing to and below ground while sinking over 25 mA. This feature was previously unavailable in operational amplifier circuits. The TLE2662 operational amplifier section has output stages that can drive 100- $\Omega$  loads to 2.5 V from a 5-V rail. With a 10-k $\Omega$  load, the output swing extends to 3.5 V and can include the positive rail with a pullup resistor.

This operational amplifier offers the high slew rate, wide bandwidth, and high input impedance commonly associated with JFET-input amplifiers, making the TLE2662 operational amplifier section suited for amplifying fast signals without loading the signal source. When not sourcing or sinking current into a load, the amplifier consumes only microamperes of supply current, thereby reducing the drain on and extending the life of the power supply.

The TLE2662 features a shutdown pin (FB/SD), which can be used to disable the switched capacitor section. When disabled, the voltage converter block draws less than 150  $\mu$ A from the power supply. This feature, combined with the operational amplifier's low quiescent current, makes the TLE2662 a real power saver in the standby mode.

The switched-capacitor building block also provides an on-board regulator; with the addition of an external divider, a well-regulated output voltage is easily obtained. Additional filtering can be added to minimize switching noise. The internal oscillator runs at a nominal frequency of 25 kHz. This can be synchronized to an external clock signal or can be varied using an external capacitor. A 2.5-V reference is brought out to SCREF for use with the on-board regulator or external circuitry.

The TLE2662 is characterized for operation over the industrial temperature range of  $-40^{\circ}\text{C}$  to  $85^{\circ}\text{C}$ . This device is available in a 16-pin wide-body surface-mount package.

DW PACKAGE  
(TOP VIEW)

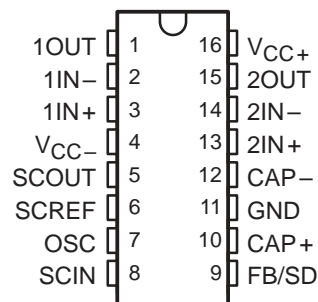

#### AVAILABLE OPTION

$T_A$	PACKAGE
	SMALL OUTLINE (DW)
$-40^{\circ}\text{C}$ to $85^{\circ}\text{C}$	TLE2662IDW

The DW package is available taped and reeled. Add the suffix R to the device type (i.e., TLE2662IDWR).

**TLE2662**  
**DUAL  $\mu$ POWER JFET-INPUT OPERATIONAL AMPLIFIER**  
**WITH SWITCHED-CAPACITOR VOLTAGE CONVERTER**

SLOS118B – DECEMBER 1992 – REVISED AUGUST 1994

**functional block diagram**

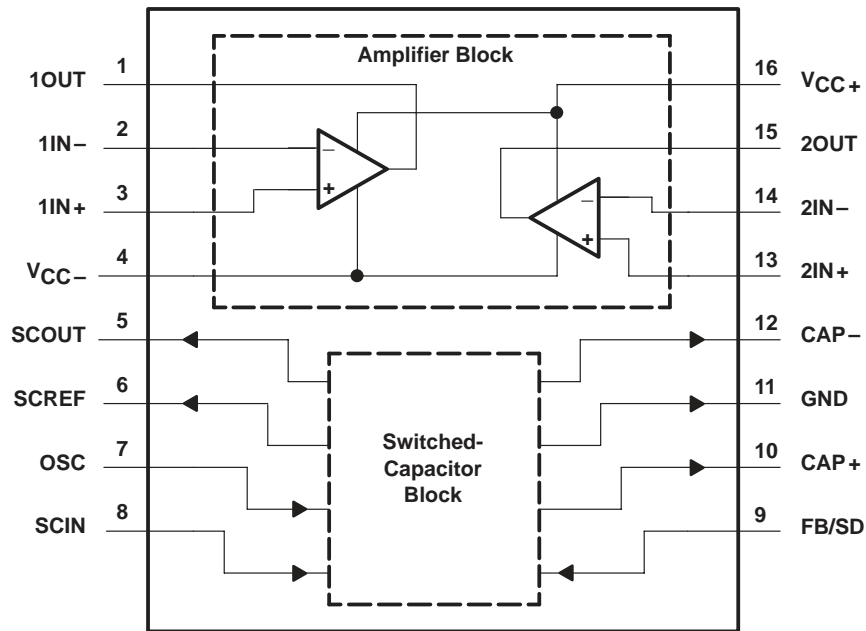

**ACTUAL DEVICE COMPONENT COUNT**

AMPLIFIER BLOCK		SWITCHED-CAPACITOR BLOCK	
Transistors	42	Transistors	71
Resistors	9	Resistors	44
Diodes	3	Diodes	2
Capacitors	2	Capacitors	5

# TLE2662

## DUAL $\mu$ POWER JFET-INPUT OPERATIONAL AMPLIFIER WITH SWITCHED-CAPACITOR VOLTAGE CONVERTER

SLOS118B – DECEMBER 1992 – REVISED AUGUST 1994

### absolute maximum ratings over operating free-air temperature range (unless otherwise noted)†

Supply voltage, SCIN (see Note 1)	16 V
Supply voltage, $V_{CC+}$ (see Note 2)	16 V
Supply voltage, $V_{CC-}$ (see Note 2)	-16 V
Differential input voltage, $V_{ID}$ (see Note 3)	32 V
Input voltage, $V_I$ (any input of amplifier) (see Note 2)	$V_{CC\pm}$
FB/SD (see Note 1)	0 V to SCIN
OSC (see Note 1)	0 V to SCREF
Input current, $I_I$ (each input of amplifier)	$\pm 1$ mA
Output current, $I_O$ (each output of amplifier)	$\pm 80$ mA
Total current into $V_{CC+}$	80 mA
Total current out of $V_{CC-}$	80 mA
Duration of short-circuit current at (or below) $T_A = 25^\circ\text{C}$ (see Note 4)	unlimited
Continuous total dissipation	See Dissipation Rating Table
Junction temperature (see Note 5)	150°C
Operating free-air temperature range, $T_A$	-40°C to 85°C
Storage temperature range	-65°C to 150°C
Lead temperature 1,6 mm (1/16 inch) from case for 10 seconds	260°C

† Stresses beyond those listed under “absolute maximum ratings” may cause permanent damage to the device. These are stress ratings only, and functional operation of the device at these or any other conditions beyond those indicated under “recommended operating conditions” is not implied. Exposure to absolute-maximum-rated conditions for extended periods may affect device reliability.

- NOTES:
- Voltage values are with respect to the switched-capacitor block GND.
  - Voltage values, except differential voltages, are with respect to the midpoint between  $V_{CC+}$  and  $V_{CC-}$ .
  - Differential voltages are at IN+ with respect to IN-.
  - The output can be shorted to either supply. Temperature and/or supply voltages must be limited to ensure that the maximum dissipation rating is not exceeded.
  - The devices are functional up to the absolute maximum junction temperature.

**DISSIPATION RATING TABLE**

PACKAGE	$T_A \leq 25^\circ\text{C}$ POWER RATING	DERATING FACTOR ABOVE $T_A = 25^\circ\text{C}$	$T_A = 70^\circ\text{C}$ POWER RATING	$T_A = 85^\circ\text{C}$ POWER RATING
DW	1025 mW	8.2 mW/°C	656 mW	533 mW

### recommended operating conditions

		MIN	MAX	UNIT
Supply voltage, $V_{CC+}/SCIN$		3.5	15	V
Common-mode input voltage, $V_{IC}$	$V_{CC\pm} = \pm 5$ V	-1.6	4	V
	$V_{CC\pm} = \pm 15$ V	-11	13	
Operating free-air temperature, $T_A$		-40	85	°C
Output current at SCOUT, $I_O$		0	100	mA



## OPERATIONAL AMPLIFIER SECTION

electrical characteristics at specified free-air temperature,  $V_{CC\pm} = \pm 5$  V (unless otherwise noted)

PARAMETER		TEST CONDITIONS†	$T_A$ ‡	MIN	TYP	MAX	UNIT	
$V_{IO}$	Input offset voltage	$V_{IC} = 0, \quad R_S = 50 \Omega$	25°C		1	5	mV	
			Full range			6.3		
$\alpha_{VIO}$	Temperature coefficient of input offset voltage		Full range		6		$\mu\text{V}/^\circ\text{C}$	
				25°C	0.04		$\mu\text{V}/\text{mo}$	
$I_{IO}$	Input offset current		25°C		1		pA	
			Full range			2	nA	
$I_{IB}$	Input bias current		25°C		3		pA	
			Full range			4	nA	
$V_{ICR}$	Common-mode input voltage range		25°C		-1.6 to 4	-2 to 6		V
			Full range		-1.6 to 4			V
$V_{OM+}$	Maximum positive peak output voltage swing	$I_L = 2$ mA	25°C	3.4	3.7		V	
			Full range		3			
		$I_L = 20$ mA	25°C	2.5	3.1			
			Full range		2			
$V_{OM-}$	Maximum negative peak output voltage swing	$I_L = 2$ mA	25°C	-3.4	-3.9		V	
			Full range		-3			
		$I_L = 20$ mA	25°C	-2.5	-2.7			
			Full range		-2			
$A_{VD}$	Large-signal differential voltage amplification	$V_O = \pm 2.8$ V, $R_L = 10$ k $\Omega$	25°C	15	80		V/mV	
			Full range		2			
		$V_O = 0$ to 2 V, $R_L = 100 \Omega$	25°C	0.75	45			
			Full range		0.5			
		$V_O = 0$ to -2 V, $R_L = 100 \Omega$	25°C	0.5	3			
			Full range		0.25			
$r_i$	Input resistance		25°C		$10^{12}$	$\Omega$		
$C_i$	Input capacitance		25°C		4	pF		
$Z_o$	Open-loop output impedance	$I_O = 0$	25°C		560	$\Omega$		
CMRR	Common-mode rejection ratio	$R_S = 50 \Omega,$ $V_{IC} = V_{ICRmin}$	25°C	65	82		dB	
			Full range		65			
$k_{SVR}$	Supply-voltage rejection ratio ( $\Delta V_{CC\pm} / \Delta V_{IO}$ )	$V_{CC\pm} = \pm 5$ V to $\pm 15$ V, $R_S = 50 \Omega$	25°C	75	93		dB	
			Full range		65			
$I_{CC}$	Supply current	$I_L = 0$	25°C	560	620		$\mu\text{A}$	
			Full range			640		

† Data applies for the amplifier block only; the switched-capacitor block is not supplying  $V_{CC-}$  supply.

‡ Full range is -40°C to 85°C.

NOTE 6: Typical values are based on the input offset voltage shift observed through 168 hours of operating life test at  $T_A = 150^\circ\text{C}$  extrapolated to  $T_A = 25^\circ\text{C}$  using the Arrhenius equation and assuming an activation energy of 0.96 eV.

**TLE2662**  
**DUAL  $\mu$ POWER JFET-INPUT OPERATIONAL AMPLIFIER**  
**WITH SWITCHED-CAPACITOR VOLTAGE CONVERTER**

SLOS118B – DECEMBER 1992 – REVISED AUGUST 1994

**operating characteristics at specified free-air temperature,  $V_{CC\pm} = \pm 5$  V**

PARAMETER		TEST CONDITIONS†	$T_A$ ‡	MIN	TYP	MAX	UNIT
SR	Slew rate at unity gain (see Figure 1)	$R_L = 10$ k $\Omega$ , $C_L = 100$ pF	25°C	2.2	3.4		V/ $\mu$ s
			Full range	1.7			
$V_n$	Equivalent input noise voltage (see Figure 2)	$f = 10$ Hz, $R_S = 20$ $\Omega$	25°C		59	100	nV/ $\sqrt{\text{Hz}}$
		$f = 1$ kHz, $R_S = 20$ $\Omega$	25°C		43	60	
$V_{N(PP)}$	Peak-to-peak equivalent input noise voltage	$f = 0.1$ Hz to 10 Hz	25°C		1.1		$\mu$ V
$I_n$	Equivalent input noise current	$f = 1$ kHz	25°C		1		fA/ $\sqrt{\text{Hz}}$
THD	Total harmonic distortion	$V_{O(PP)} = 2$ V, $f = 10$ kHz, $A_{VD} = 2$ , $R_L = 10$ k $\Omega$	25°C		0.025%		
$B_1$	Unity-gain bandwidth (see Figure 3)	$R_L = 10$ k $\Omega$ , $C_L = 100$ pF	25°C		1.8		MHz
		$R_L = 100$ $\Omega$ , $C_L = 100$ pF	25°C		1.3		
$t_s$	Settling time	To 0.1%	25°C		5		$\mu$ s
		To 0.01%	25°C		10		
$B_{OM}$	Maximum output-swing bandwidth	$A_{VD} = 1$ , $R_L = 10$ k $\Omega$	25°C		140		kHz
$\phi_m$	Phase margin at unity gain (see Figure 3)	$R_L = 10$ k $\Omega$ , $C_L = 100$ pF	25°C		58°		
		$R_L = 100$ $\Omega$ , $C_L = 100$ pF	25°C		75°		

† Data applies for the amplifier block only; the switched-capacitor block is not supplying  $V_{CC-}$  supply.

‡ Full range is  $-40^\circ\text{C}$  to  $85^\circ\text{C}$ .

# TLE2662

## DUAL $\mu$ POWER JFET-INPUT OPERATIONAL AMPLIFIER WITH SWITCHED-CAPACITOR VOLTAGE CONVERTER

SLOS118B – DECEMBER 1992 – REVISED AUGUST 1994

### electrical characteristics at specified free-air temperature, $V_{CC\pm} = \pm 15$ V (unless otherwise noted)

PARAMETER		TEST CONDITIONS†	$T_A$ ‡	MIN	TYP	MAX	UNIT
$V_{IO}$	Input offset voltage	$V_{IC} = 0, R_S = 50 \Omega$	25°C	0.9	4		mV
			Full range		5.3		
$\alpha_{VIO}$	Temperature coefficient of input offset voltage		Full range	6			$\mu V/^\circ C$
	Input offset voltage long-term drift (see Note 6)		25°C	0.04			$\mu V/mo$
$I_{IO}$	Input offset current		25°C	2			pA
			Full range		3		nA
$I_{IB}$	Input bias current		25°C	4			pA
			Full range		5		nA
$V_{ICR}$	Common-mode input voltage range	25°C	-11 to 13	-12 to 16		V	
		Full range	-11 to 13			V	
$V_{OM+}$	Maximum positive peak output voltage swing	$I_L = 2$ mA	25°C	13.2	13.7		V
			Full range	13			
			25°C	12.5	13.2		
			Full range	12			
$V_{OM-}$	Maximum negative peak output voltage swing	$I_L = 2$ mA	25°C	-13.2	-13.7		V
			Full range	-13			
			25°C	-12.5	-13		
			Full range	-12			
$A_{VD}$	Large-signal differential voltage amplification	$V_O = \pm 10$ V, $R_L = 10$ k $\Omega$	25°C	30	230		V/mV
			Full range	20			
			25°C	25	100		
			Full range	10			
			25°C	3	25		
			Full range	1			
$r_i$	Input resistance		25°C	10 <sup>12</sup>		$\Omega$	
$C_i$	Input capacitance		25°C	4		pF	
$z_o$	Open-loop output impedance	$I_O = 0$	25°C	560		$\Omega$	
CMRR	Common-mode rejection ratio	$R_S = 50 \Omega, V_{IC} = V_{ICRmin}$	25°C	72	90		dB
			Full range	65			
kSVR	Supply-voltage rejection ratio ( $\Delta V_{CC\pm} / \Delta V_{IO}$ )	$V_{CC\pm} = \pm 5$ V to $\pm 15$ V, $R_S = 50 \Omega$	25°C	75	93		dB
			Full range	65			
$I_{CC}$	Supply current	$I_L = 0$	25°C	625	690		$\mu A$
			Full range		720		

† Data applies for the amplifier block only; the switched-capacitor block is not supplying  $V_{CC-}$  supply.

‡ Full range is  $-40^\circ C$  to  $85^\circ C$ .

NOTE 6: Typical values are based on the input offset voltage shift observed through 168 hours of operating life test at  $T_A = 150^\circ C$  extrapolated to  $T_A = 25^\circ C$  using the Arrhenius equation and assuming an activation energy of 0.96 eV.



# TLE2662

## DUAL $\mu$ POWER JFET-INPUT OPERATIONAL AMPLIFIER WITH SWITCHED-CAPACITOR VOLTAGE CONVERTER

SLOS118B – DECEMBER 1992 – REVISED AUGUST 1994

### operating characteristics at specified free-air temperature, $V_{CC\pm} = \pm 15$ V

PARAMETER		TEST CONDITIONS†	$T_A$ ‡	MIN	TYP	MAX	UNIT
SR	Slew rate at unity gain (see Figure 1)	$R_L = 10$ k $\Omega$ , $C_L = 100$ pF	25°C	2.6	3.4		V/ $\mu$ s
			Full range	2.1			
$V_n$	Equivalent input noise voltage (see Figure 2)	$f = 10$ Hz, $R_S = 20$ $\Omega$	25°C		70	100	nV/ $\sqrt{\text{Hz}}$
		$f = 1$ kHz, $R_S = 20$ $\Omega$	25°C		40	60	
$V_{N(PP)}$	Peak-to-peak equivalent input noise voltage	$f = 0.1$ Hz to 10 Hz	25°C		1.1		$\mu$ V
$I_n$	Equivalent input noise current	$f = 1$ kHz	25°C		1.1		fA/ $\sqrt{\text{Hz}}$
THD	Total harmonic distortion	$V_{O(PP)} = 2$ V, $f = 10$ kHz, $A_{VD} = 2$ , $R_L = 10$ k $\Omega$	25°C		0.025%		
$B_1$	Unity-gain bandwidth (see Figure 3)	$R_L = 10$ k $\Omega$ , $C_L = 100$ pF	25°C		2		MHz
		$R_L = 600$ $\Omega$ , $C_L = 100$ pF	25°C		1.5		
$t_s$	Settling time	To 0.1%	25°C		5		$\mu$ s
		To 0.01%	25°C		10		
B <sub>OM</sub>	Maximum output-swing bandwidth	$A_{VD} = 1$ , $R_L = 10$ k $\Omega$	25°C		40		kHz
$\phi_m$	Phase margin at unity gain (see Figure 3)	$R_L = 10$ k $\Omega$ , $C_L = 100$ pF	25°C		60°		
		$R_L = 600$ $\Omega$ , $C_L = 100$ pF	25°C		70°		

† Data applies for the amplifier block only; the switched-capacitor block is not supplying  $V_{CC-}$  supply.

‡ Full range is  $-40^\circ\text{C}$  to  $85^\circ\text{C}$ .

**TLE2662**  
**DUAL  $\mu$ POWER JFET-INPUT OPERATIONAL AMPLIFIER**  
**WITH SWITCHED-CAPACITOR VOLTAGE CONVERTER**

SLOS118B – DECEMBER 1992 – REVISED AUGUST 1994

**SWITCHED-CAPACITOR SECTION**

**electrical characteristics over recommended supply voltage range and at specified free-air temperature**

PARAMETER	TEST CONDITION <sup>†</sup>		T <sub>A</sub> <sup>‡</sup>	MIN	TYP	MAX	UNIT
Regulated output voltage, SCOUT	R <sub>L(SCOUT)</sub> = 500 $\Omega$	SCIN = 7 V, See Note 7	25°C	-5.2	-5	-4.7	V
		SCIN = 5 V, See Note 8		-4.25	-4	-3.75	
Input regulation	R <sub>L(SCOUT)</sub> = 500 $\Omega$	SCIN = 7 V to 12 V, See Note 7	Full range	5		25	mV
		SCIN = 5 V to 15 V, See Note 8		27			
Output regulation	R <sub>L(SCOUT)</sub> = 100 $\Omega$ to 500 $\Omega$	SCIN = 7 V, See Note 7	Full range	10		50	mV
		SCIN = 5 V, See Note 8		100			
Voltage loss, SCIN –  SCOUT  (see Note 9)	SCIN = 7 V, CIN = COUT = 100- $\mu$ F tantalum	I <sub>O</sub> = 10 mA	Full range	0.35	0.55		V
		I <sub>O</sub> = 100 mA		1.1 1.6			
Output resistance	SCIN = 7 V, See Note 10	$\Delta$ I <sub>O</sub> = 10 mA to 100 mA,	Full range	10		15	$\Omega$
Oscillator frequency			Full range	15	25	35	kHz
Reference voltage, V <sub>ref</sub>	SCIN = 7 V, I <sub>ref</sub> = 60 $\mu$ A	25°C		2.35	2.5	2.65	V
		Full range		2.25		2.75	
	SCIN = 5 V, I <sub>ref</sub> = 50 $\mu$ A	25°C		2.35	2.5	2.65	V
		Full range		2.25		2.75	
Maximum switch current			25°C	300		mA	
Supply current, I <sub>S</sub>	I <sub>O</sub> = 0	SCIN = 3.5 V	Full range	2.5		3.5	mA
		SCIN = 15 V		3		4.5	
Supply current in shutdown	V <sub>(FB/SD)</sub> = 0, I <sub>O</sub> = 0,	SCIN = 5 V	Full range	100	150	$\mu$ A	

<sup>†</sup> Data applies for the switched-capacitor block only. Amplifier block is not connected.

<sup>‡</sup> Full range is -40°C to 85°C.

- NOTES:
- All regulation specifications are for the switched-capacitor section connected as a positive to negative converter/regulator with R1 = 20 k $\Omega$ , R2 = 102.5 k $\Omega$ , CIN = 10  $\mu$ F (tantalum), COUT = 100  $\mu$ F (tantalum) and C1 = 0.002  $\mu$ F (see Figure 63).
  - All regulation specifications are for the switched-capacitor section connected as a positive to negative converter/regulator with R1 = 23.7 k $\Omega$ , R2 = 102.2 k $\Omega$ , CIN = 10  $\mu$ F (tantalum), COUT = 100  $\mu$ F (tantalum) and C1 = 0.002  $\mu$ F (see Figure 63).
  - For voltage-loss tests, the switched-capacitor section is connected as a voltage inverter, with SCREF, OSC, and FB/SD unconnected. The voltage losses may be higher in other configurations.
  - Output resistance is defined as the slope of the curve ( $\Delta$ V<sub>O</sub> vs  $\Delta$ I<sub>O</sub>) for output currents of 10 mA to 100 mA. This represents the linear portion of the curve. The incremental slope of the curve is higher at currents less than 10 mA due to the characteristics of the switch transistors.





**TLE2662**  
**DUAL  $\mu$ POWER JFET-INPUT OPERATIONAL AMPLIFIER**  
**WITH SWITCHED-CAPACITOR VOLTAGE CONVERTER**

SLOS118B – DECEMBER 1992 – REVISED AUGUST 1994

**AMPLIFIER AND SWITCHED-CAPACITOR SECTIONS CONNECTED**

electrical characteristics,  $V_{CC+} = 5\text{ V}$ ,  $T_A = 25^\circ\text{C}$  (see Figure 4)

PARAMETER	TEST CONDITIONS	MIN	TYP	MAX	UNIT
Maximum positive peak output voltage swing, $V_{OM+}$	$R_L = 10\text{ k}\Omega$		3.7		V
	$R_L = 600\ \Omega$		3.5		
	$R_L = 100\ \Omega$		3.1		
Maximum negative peak output voltage swing, $V_{OM-}$	$R_L = 10\text{ k}\Omega$		-3.7		V
	$R_L = 600\ \Omega$		-3.0		
	$R_L = 100\ \Omega$		-2.2		
Voltage loss, $SCIN -  SCOUT $ (see Note 9)	CIN = COUT = 100- $\mu$ F tantalum, $V_{ID} = -100\text{ mV}$ , Both amplifiers	$R_L = 10\text{ k}\Omega$	0.46		V
		$R_L = 600\ \Omega$	0.50		
		$R_L = 100\ \Omega$	0.9		

NOTES: 9. For voltage-loss tests, the switched-capacitor section is connected as a voltage inverter with SCREF, OSC, and FB/SD unconnected. The voltage losses may be higher in other configurations.

supply current (no load),  $T_A = 25^\circ\text{C}$

PARAMETER	TEST CONDITIONS	MIN	TYP	MAX	UNIT
Supply current	$V_{CC+} = 5\text{ V}$ , $SCIN = 5\text{ V}$ , $V_{(FB/SD)} = 2.5\text{ V}$ , $V_O = 0$		3.4		mA
Supply current in shutdown	$V_{CC+} = 5\text{ V}$ , $SCIN = 5\text{ V}$ , $V_{(FB/SD)} = 0\text{ V}$ , $V_O = 0$		265		$\mu\text{A}$

**PARAMETER MEASUREMENT INFORMATION**

operational amplifier

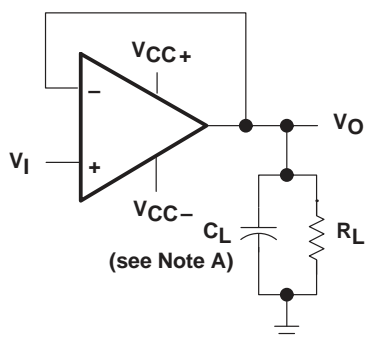

NOTE A:  $C_L$  includes fixture capacitance.

**Figure 1. Slew-Rate Test Circuit**

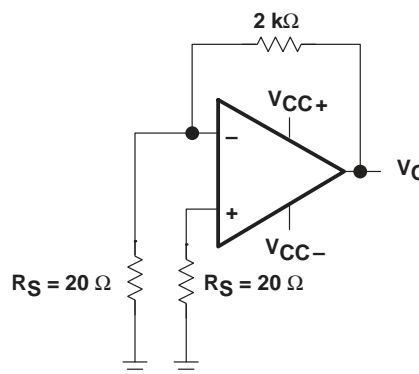
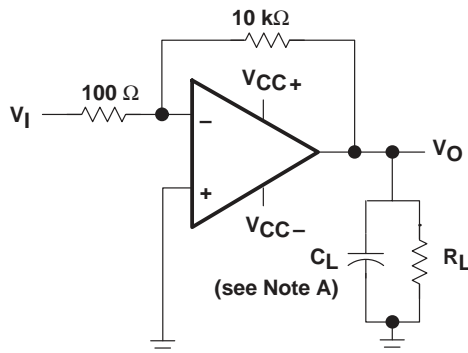

**Figure 2. Noise-Voltage Test Circuit**

**TLE2662**  
**DUAL  $\mu$ POWER JFET-INPUT OPERATIONAL AMPLIFIER**  
**WITH SWITCHED-CAPACITOR VOLTAGE CONVERTER**

SLOS118B – DECEMBER 1992 – REVISED AUGUST 1994

**PARAMETER MEASUREMENT INFORMATION**



NOTE A:  $C_L$  includes fixture capacitance.

**Figure 3. Unity-Gain Bandwidth and Phase-Margin Test Circuit**

**amplifier input bias offset current**

At the picoampere bias-current level typical of the TLE2662, accurate measurement of the amplifier's bias current becomes difficult. Not only does this measurement require a picoammeter, but test socket leakages can easily exceed the actual device bias currents. To accurately measure these small currents, Texas Instruments uses a two-step process. The socket leakage is measured using picoammeters with bias voltages applied but with no device in the socket. The device is then inserted into the socket and a second test that measures both the socket leakage and the device input bias current is performed. The two measurements are then subtracted algebraically to determine the bias current of the device.

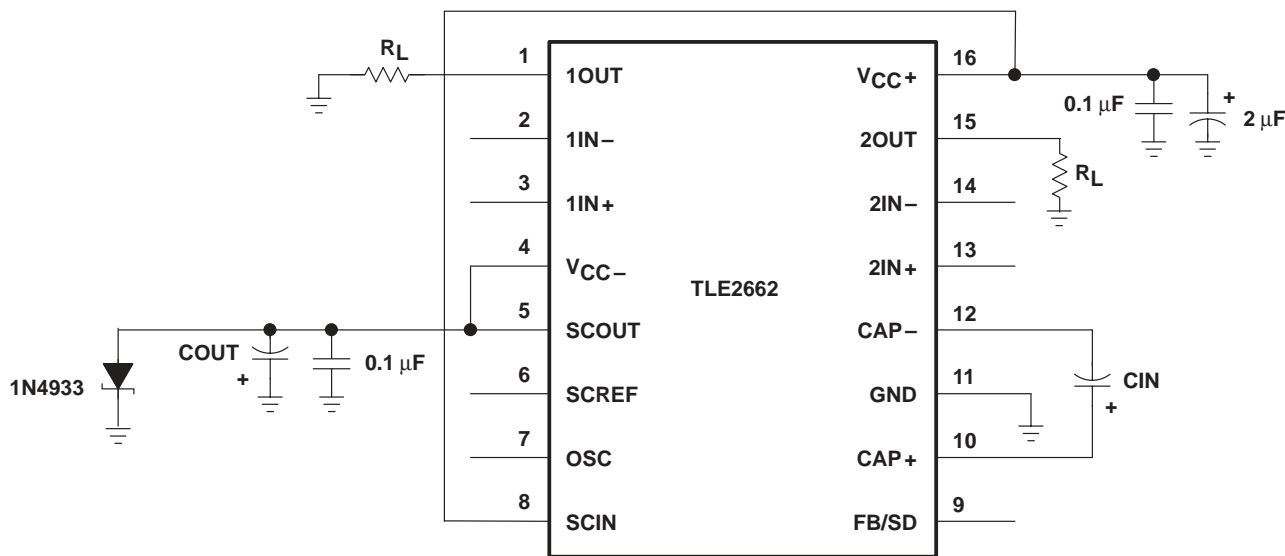

**Figure 4. Test Circuit**

**TLE2662**  
**DUAL  $\mu$ POWER JFET-INPUT OPERATIONAL AMPLIFIER**  
**WITH SWITCHED-CAPACITOR VOLTAGE CONVERTER**

SLOS118B – DECEMBER 1992 – REVISED AUGUST 1994

**TYPICAL CHARACTERISTICS**

**Table of Graphs**

**operational amplifier section**

		<b>FIGURE</b>	
$V_{IO}$	Input offset voltage	Distribution	5
$I_{IB}$	Input bias current	vs Free-air temperature	6
$I_{IO}$	Input offset current	vs Free-air temperature	6
$V_{IC}$	Common-mode input voltage	vs Free-air temperature	7
$V_{OM}$	Maximum peak output voltage	vs Output current vs Supply voltage	8, 9 10, 11, 12
$V_{O(PP)}$	Maximum peak-to-peak output voltage	vs Frequency	13, 14
$A_{VD}$	Differential voltage amplification	vs Frequency vs Free-air temperature	15 16
$I_{OS}$	Short-circuit output current	vs Time vs Free-air temperature	17 18
$z_o$	Output impedance	vs Frequency	19
CMRR	Common-mode rejection ratio	vs Frequency	20
$I_{CC}$	Supply current	vs Supply voltage vs Free-air temperature	21 22
	Pulse response	Small signal Large signal	23, 24 25, 26
	Noise voltage (referenced to input)	0.1 to 10 Hz	27
$V_n$	Equivalent input noise voltage	vs Frequency	28
THD	Total harmonic distortion	vs Frequency	29, 30
$B_1$	Unity-gain bandwidth	vs Supply voltage vs Free-air temperature	31 32
$\phi_m$	Phase margin	vs Supply voltage vs Load capacitance vs Free-air temperature	33 34 35
	Phase shift	vs Frequency	15

**switched-capacitor section**

	Shutdown threshold voltage	vs Free-air temperature	36
$I_{CC}$	Supply current	vs Input voltage	37
$f_{osc}$	Oscillator frequency	vs Free-air temperature	38
	Supply current in shutdown	vs Input voltage	39
	Average supply current	vs Output current	40
	Output voltage loss	vs Input capacitance vs Oscillator frequency	41 42, 43
$V_O$	Regulated output voltage	vs Free-air temperature	44
	Reference voltage change	vs Free-air temperature	45
	Voltage loss	vs Output current	46

**TLE2662**  
**DUAL  $\mu$ POWER JFET-INPUT OPERATIONAL AMPLIFIER**  
**WITH SWITCHED-CAPACITOR VOLTAGE CONVERTER**

SLOS118B – DECEMBER 1992 – REVISED AUGUST 1994

**TYPICAL CHARACTERISTICS†**  
**OPERATIONAL AMPLIFIER SECTION**

**DISTRIBUTION OF INPUT OFFSET VOLTAGE**

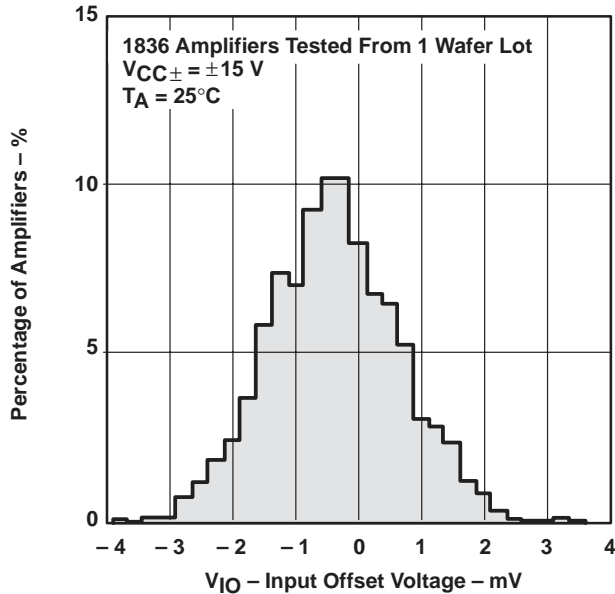

**Figure 5**

**INPUT BIAS CURRENT AND INPUT OFFSET CURRENT**  
**vs**  
**FREE-AIR TEMPERATURE**

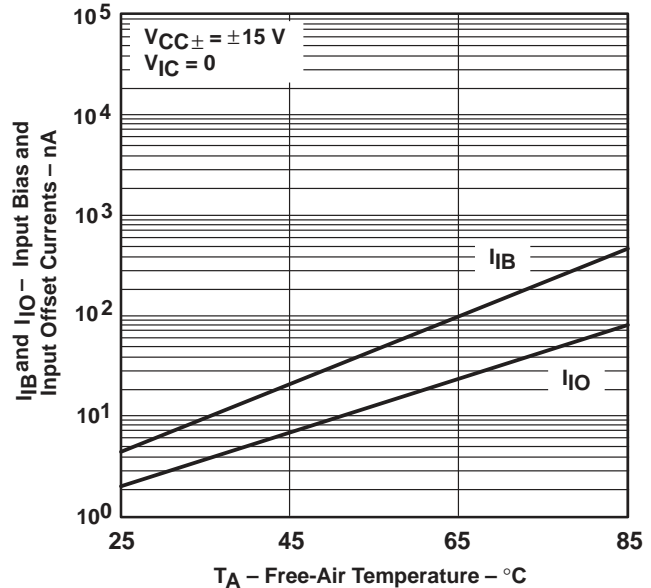

**Figure 6**

**COMMON-MODE INPUT VOLTAGE**  
**vs**  
**FREE-AIR TEMPERATURE**

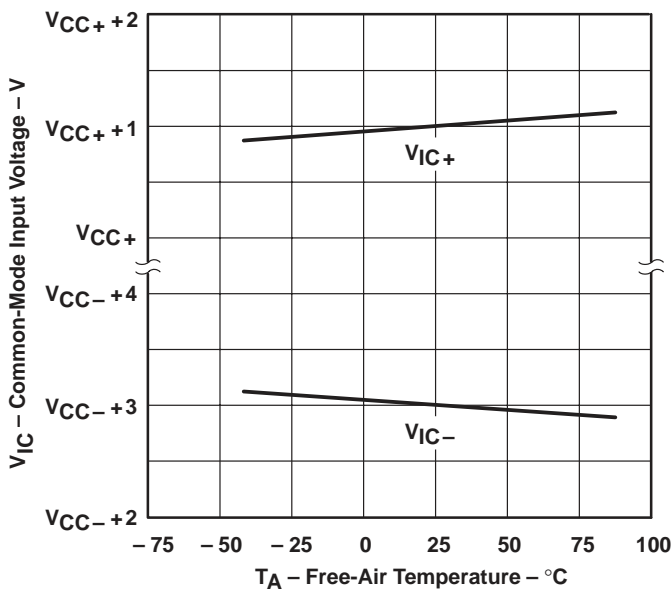

**Figure 7**

**MAXIMUM POSITIVE PEAK OUTPUT VOLTAGE**  
**vs**  
**OUTPUT CURRENT**

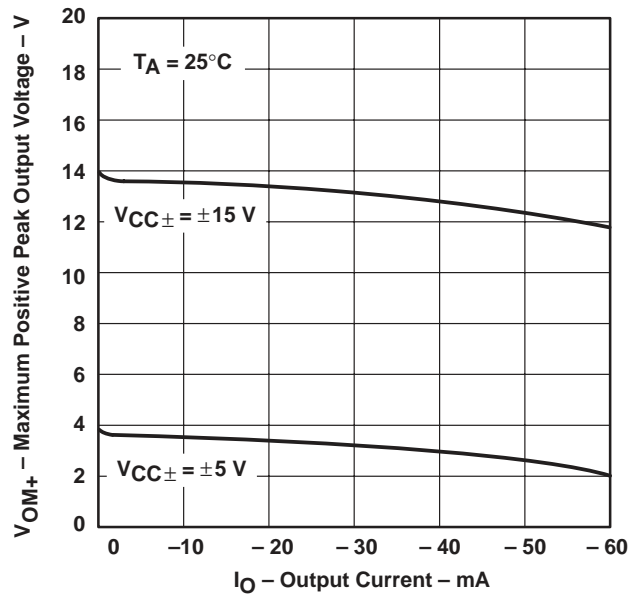
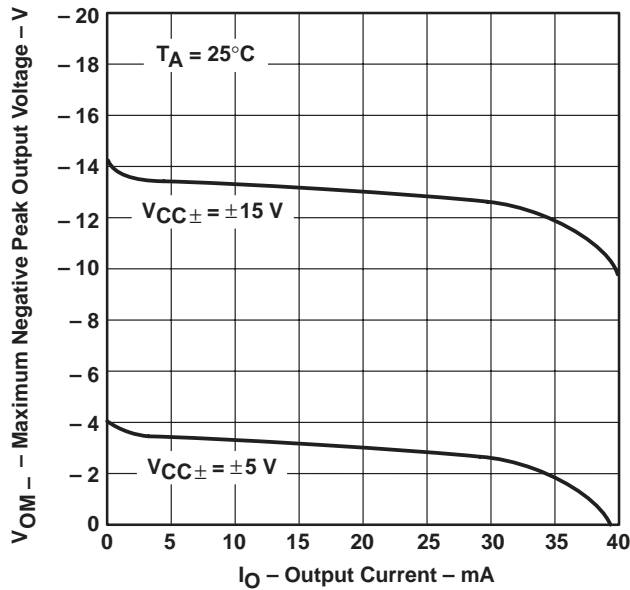

**Figure 8**

† Data applies for the amplifier block only; the switched-capacitor block is not supplying  $V_{CC-}$  supply.

**TYPICAL CHARACTERISTICS†**  
**OPERATIONAL AMPLIFIER SECTION**

**MAXIMUM NEGATIVE PEAK OUTPUT VOLTAGE**  
**vs**  
**OUTPUT CURRENT**



**MAXIMUM PEAK OUTPUT VOLTAGE**  
**vs**  
**SUPPLY VOLTAGE**

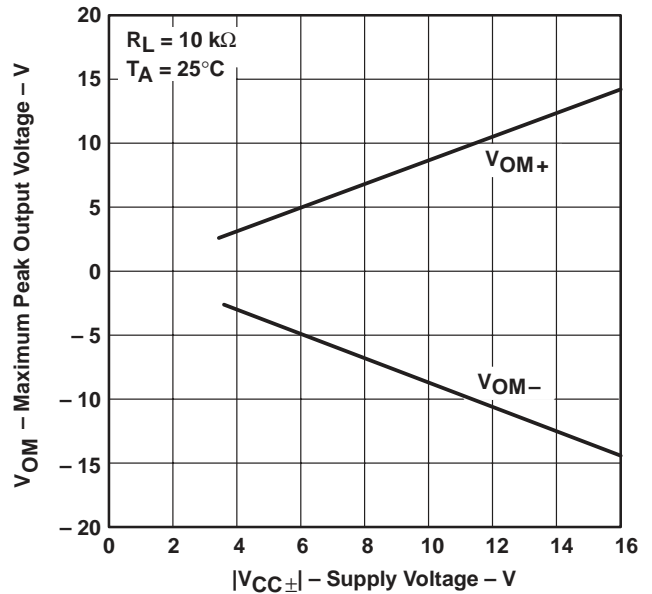

**MAXIMUM PEAK OUTPUT VOLTAGE**  
**vs**  
**SUPPLY VOLTAGE**

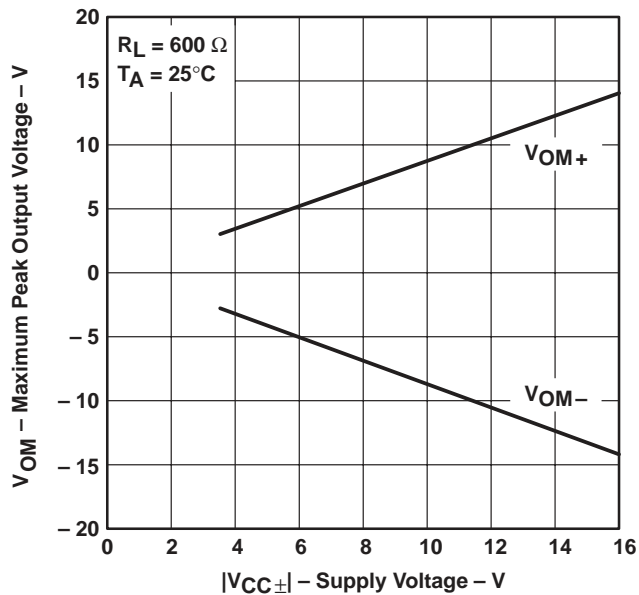

**MAXIMUM PEAK OUTPUT VOLTAGE**  
**vs**  
**SUPPLY VOLTAGE**

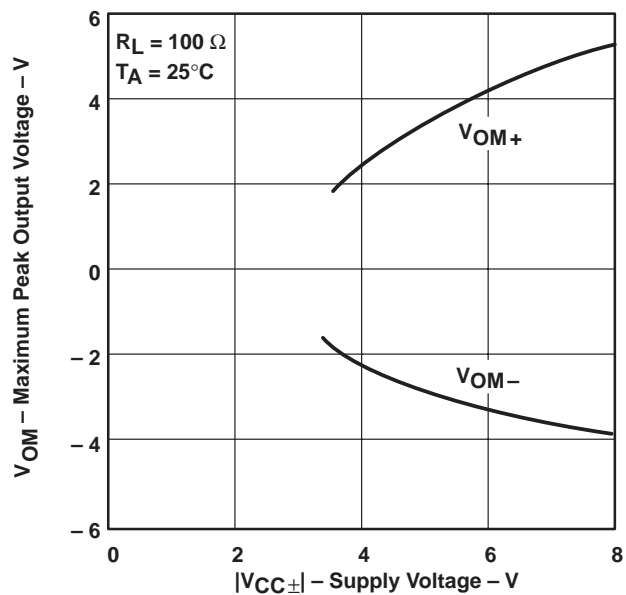

† Data applies for the amplifier block only; the switched-capacitor block is not supplying  $V_{CC-}$  supply.

**TLE2662**  
**DUAL  $\mu$ POWER JFET-INPUT OPERATIONAL AMPLIFIER**  
**WITH SWITCHED-CAPACITOR VOLTAGE CONVERTER**

SLOS118B – DECEMBER 1992 – REVISED AUGUST 1994

**TYPICAL CHARACTERISTICS†**  
**OPERATIONAL AMPLIFIER SECTION**

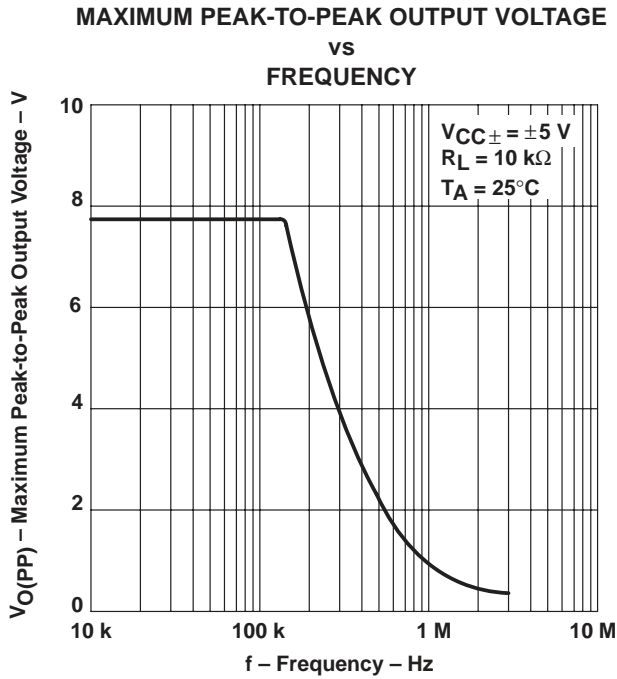

Figure 13

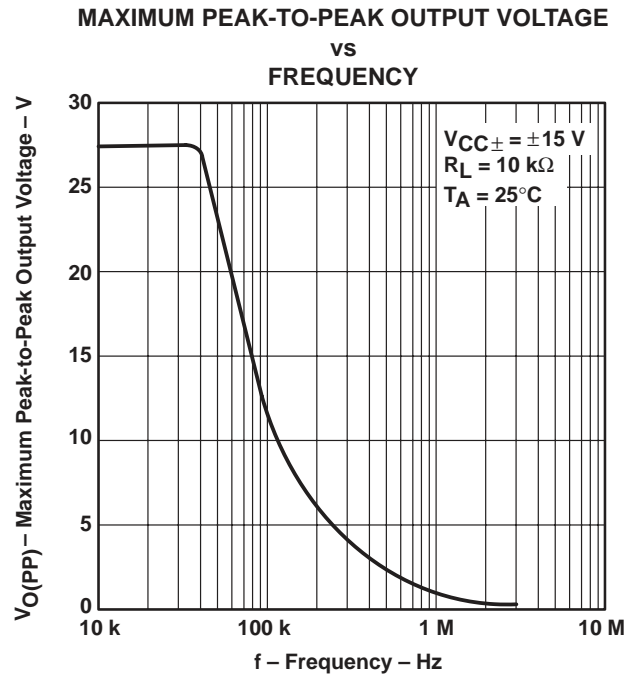

Figure 14

**LARGE-SIGNAL DIFFERENTIAL VOLTAGE**  
**AMPLIFICATION and PHASE SHIFT**  
**VS**  
**FREQUENCY**

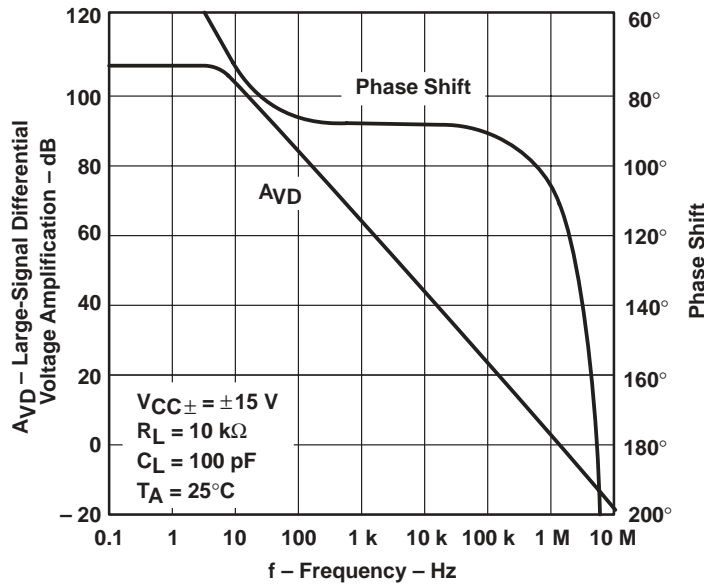

Figure 15

† Data applies for the amplifier block only; the switched-capacitor block is not supplying  $V_{CC-}$  supply.

**TYPICAL CHARACTERISTICS†**  
**OPERATIONAL AMPLIFIER SECTION**

**LARGE-SIGNAL DIFFERENTIAL VOLTAGE**  
**AMPLIFICATION**  
**vs**  
**FREE-AIR TEMPERATURE**

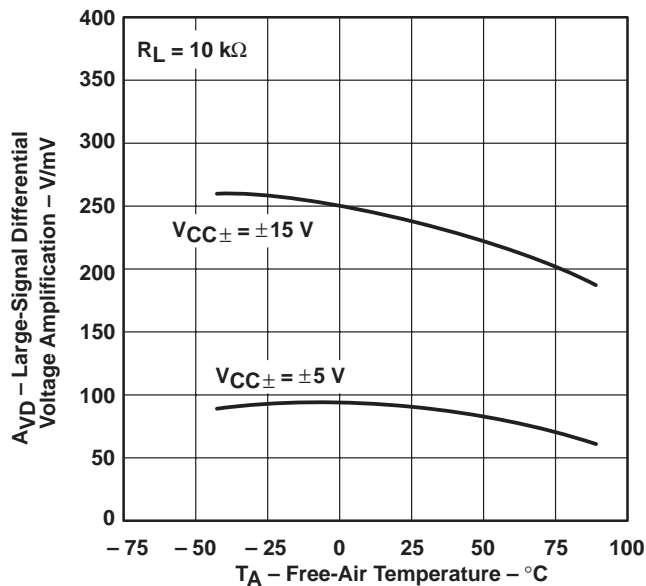

Figure 16

**SHORT-CIRCUIT OUTPUT CURRENT**  
**vs**  
**TIME**

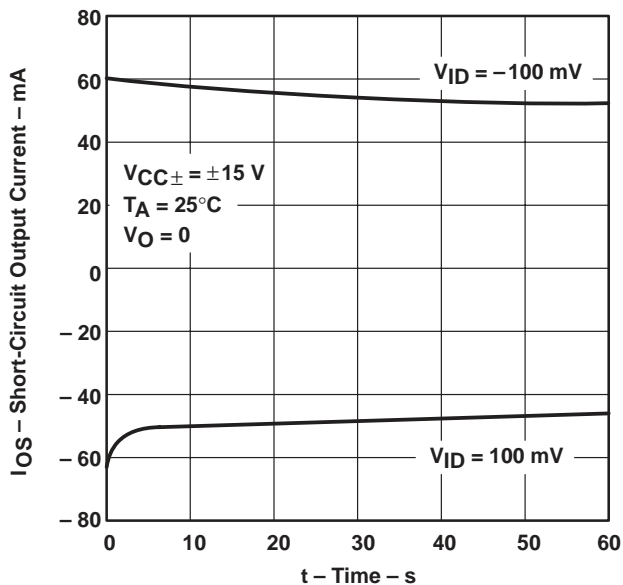

Figure 17

**SHORT-CIRCUIT OUTPUT CURRENT**  
**vs**  
**FREE-AIR TEMPERATURE**

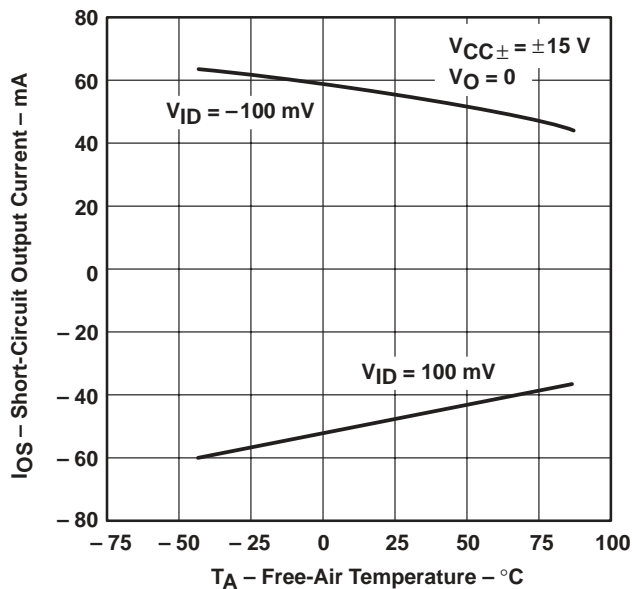

Figure 18

† Data applies for the amplifier block only; the switched-capacitor block is not supplying  $V_{CC-}$  supply.

**TLE2662**  
**DUAL  $\mu$ POWER JFET-INPUT OPERATIONAL AMPLIFIER**  
**WITH SWITCHED-CAPACITOR VOLTAGE CONVERTER**

SLOS118B – DECEMBER 1992 – REVISED AUGUST 1994

**TYPICAL CHARACTERISTICS†**  
**OPERATIONAL AMPLIFIER SECTION**

**OUTPUT IMPEDANCE**  
**VS**  
**FREQUENCY**

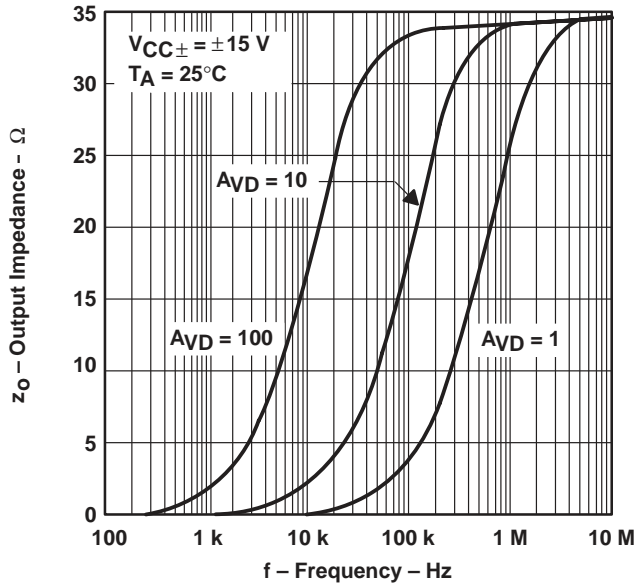

**Figure 19**

**COMMON-MODE REJECTION RATIO**  
**VS**  
**FREQUENCY**

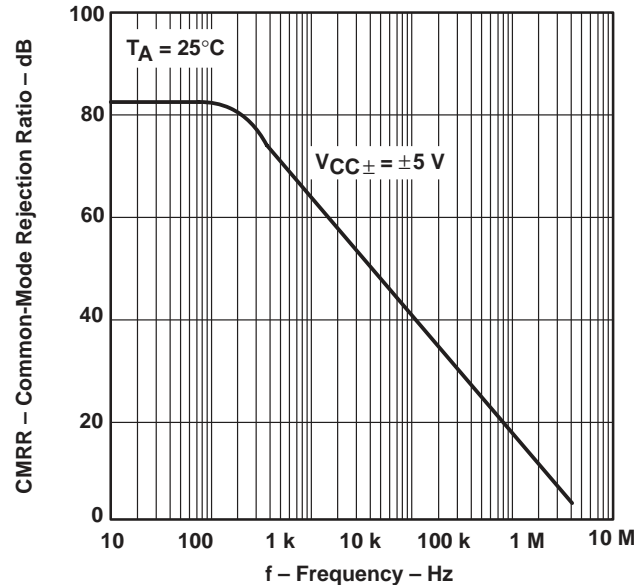

**Figure 20**

**SUPPLY CURRENT**  
**VS**  
**SUPPLY VOLTAGE**

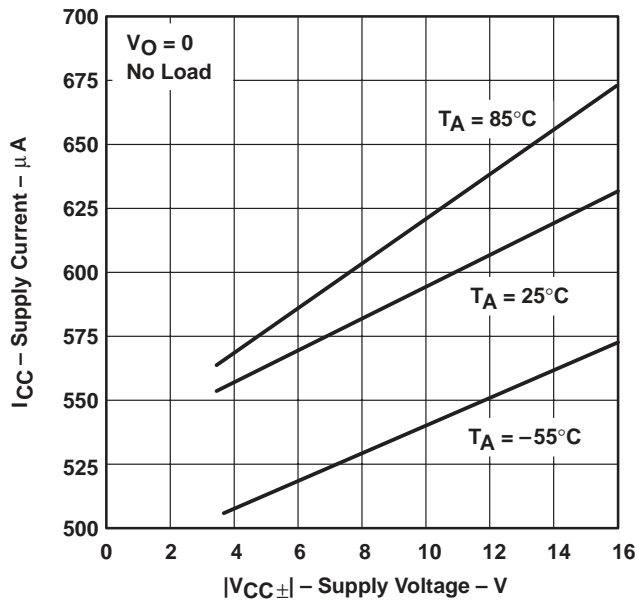

**Figure 21**

**SUPPLY CURRENT**  
**VS**  
**FREE-AIR TEMPERATURE**

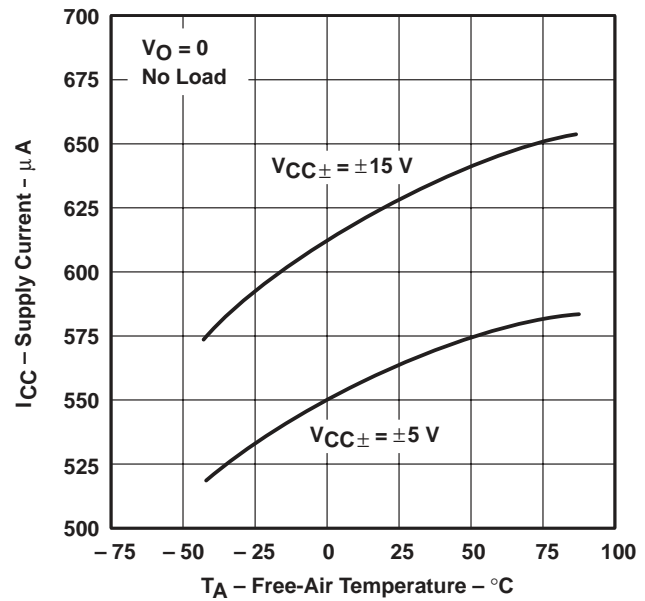

**Figure 22**

† Data applies for the amplifier block only; the switched-capacitor block is not supplying  $V_{CC-}$  supply.





**TYPICAL CHARACTERISTICS†**  
**OPERATIONAL AMPLIFIER SECTION**

**VOLTAGE-FOLLOWER SMALL-SIGNAL PULSE RESPONSE**

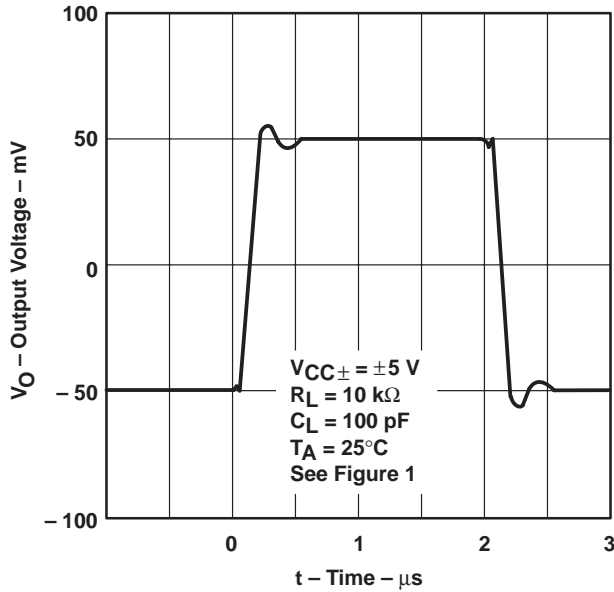

**VOLTAGE-FOLLOWER SMALL-SIGNAL PULSE RESPONSE**

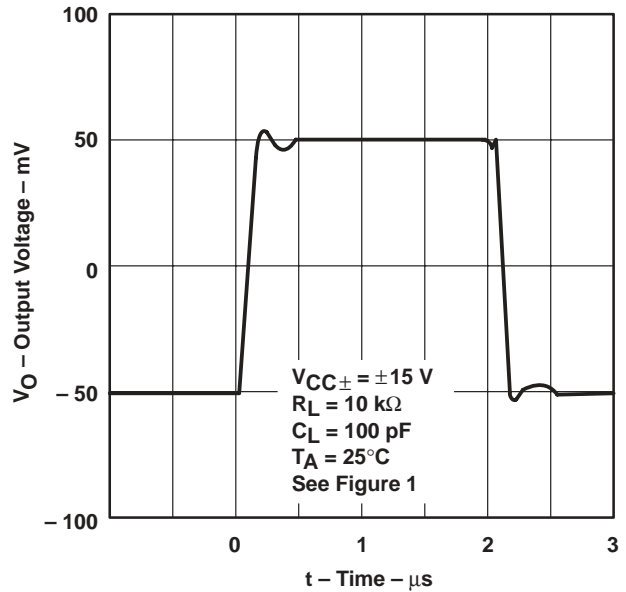

**VOLTAGE-FOLLOWER LARGE-SIGNAL PULSE RESPONSE**

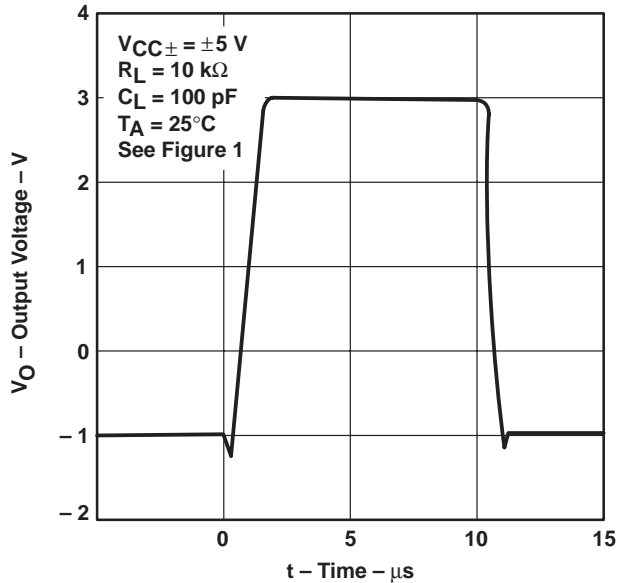

**VOLTAGE-FOLLOWER LARGE-SIGNAL PULSE RESPONSE**

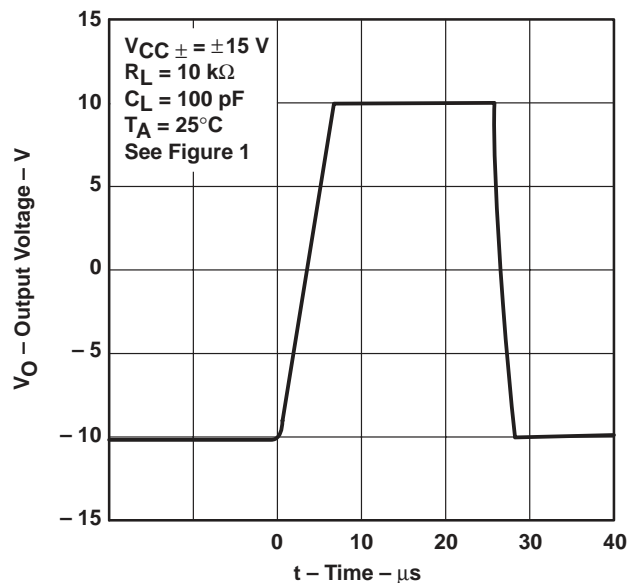

† Data applies for the amplifier block only; the switched-capacitor block is not supplying  $V_{CC-}$  supply.

**TLE2662**  
**DUAL  $\mu$ POWER JFET-INPUT OPERATIONAL AMPLIFIER**  
**WITH SWITCHED-CAPACITOR VOLTAGE CONVERTER**

SLOS118B – DECEMBER 1992 – REVISED AUGUST 1994

**TYPICAL CHARACTERISTICS†**  
**OPERATIONAL AMPLIFIER SECTION**

**NOISE VOLTAGE**  
**(REFERRED TO INPUT)**  
**0.1 TO 10 Hz**

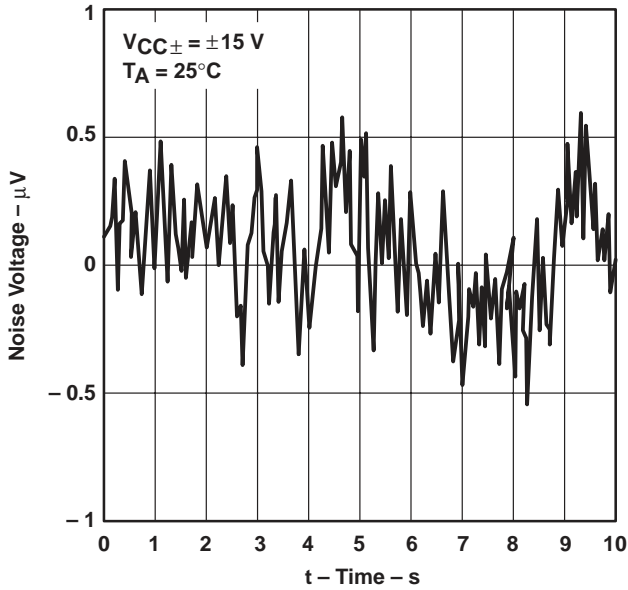

**Figure 27**

**EQUIVALENT INPUT NOISE VOLTAGE**  
**VS**  
**FREQUENCY**

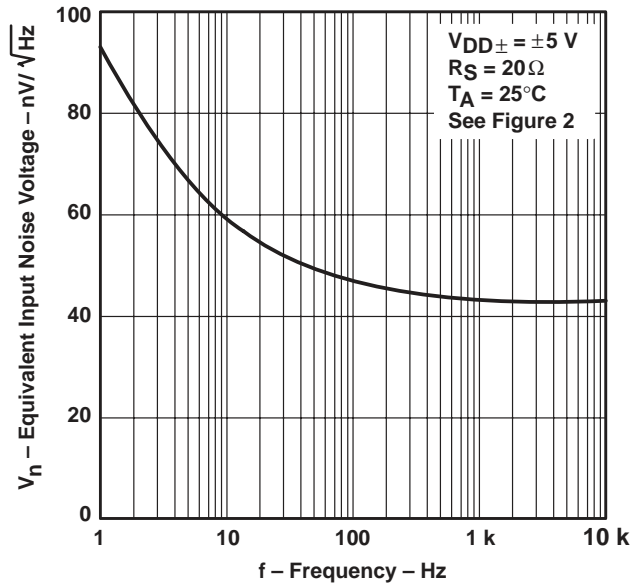

**Figure 28**

**TOTAL HARMONIC DISTORTION**  
**VS**  
**FREQUENCY**

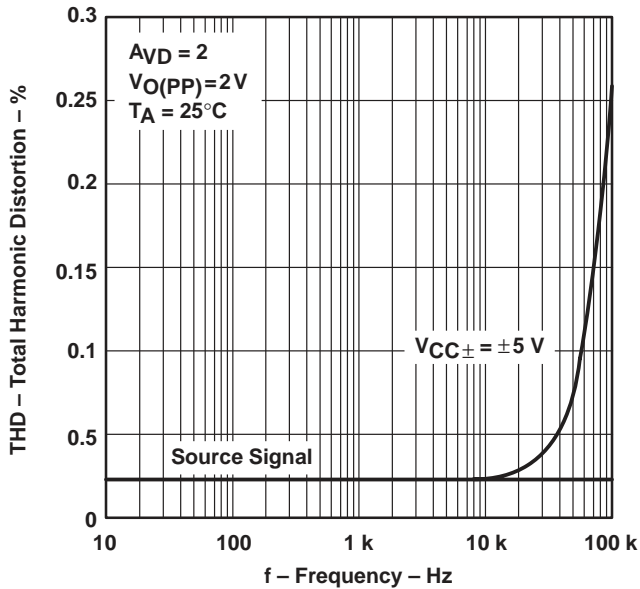

**Figure 29**

**TOTAL HARMONIC DISTORTION**  
**VS**  
**FREQUENCY**

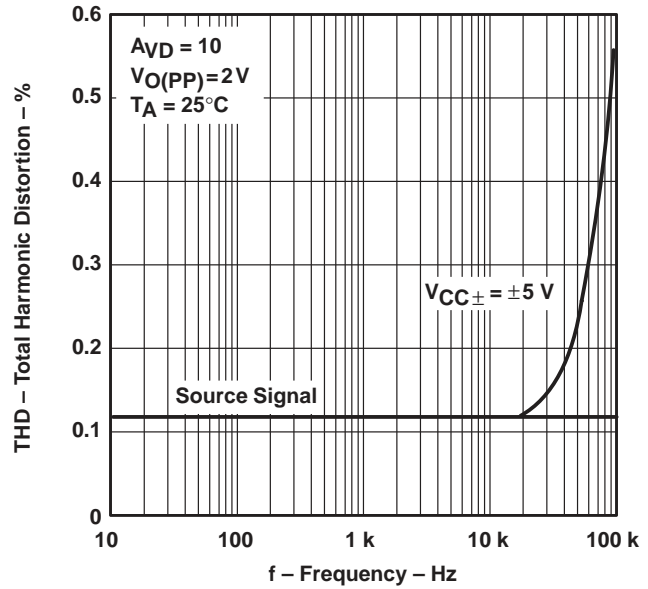
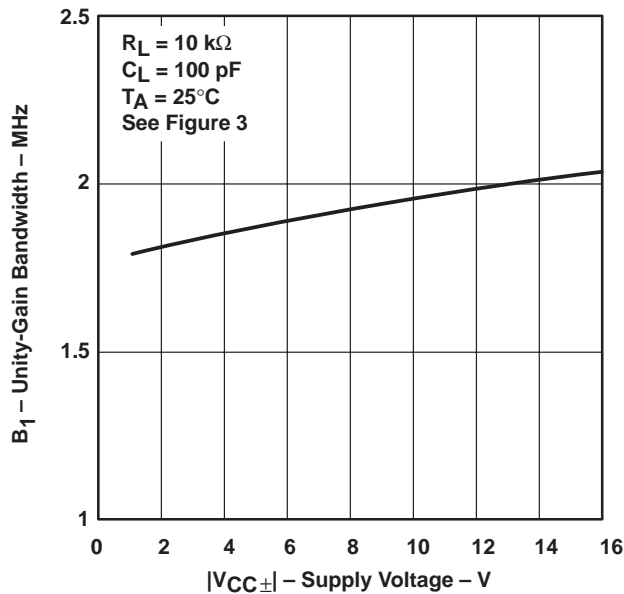

**Figure 30**

† Data applies for the amplifier block only; the switched-capacitor block is not supplying  $V_{CC-}$  supply.

**TYPICAL CHARACTERISTICS†  
 OPERATIONAL AMPLIFIER SECTION**

**UNITY-GAIN BANDWIDTH  
 vs  
 SUPPLY VOLTAGE**



**Figure 31**

**UNITY-GAIN BANDWIDTH  
 vs  
 FREE-AIR TEMPERATURE**

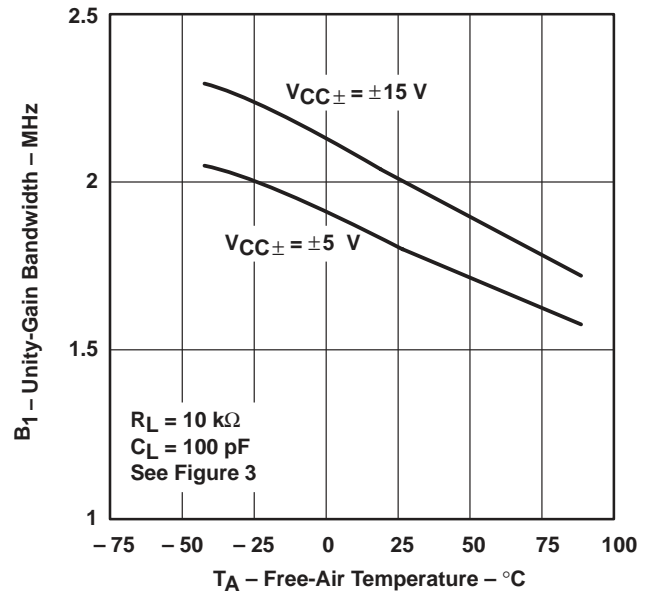

**Figure 32**

**PHASE MARGIN  
 vs  
 SUPPLY VOLTAGE**

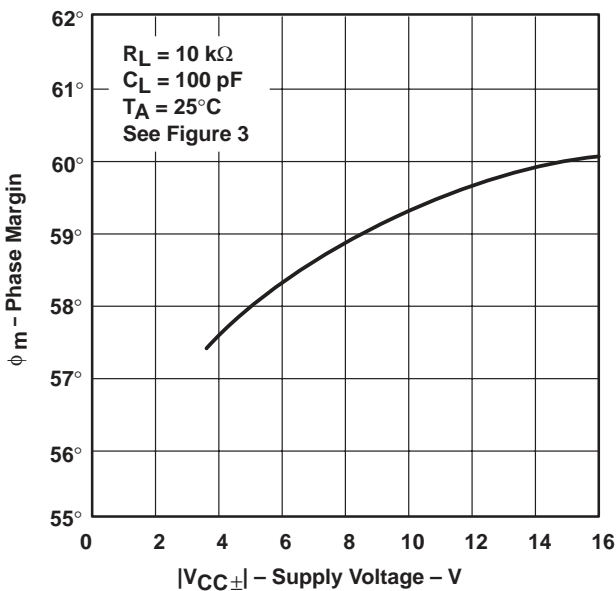

**Figure 33**

**PHASE MARGIN  
 vs  
 LOAD CAPACITANCE**

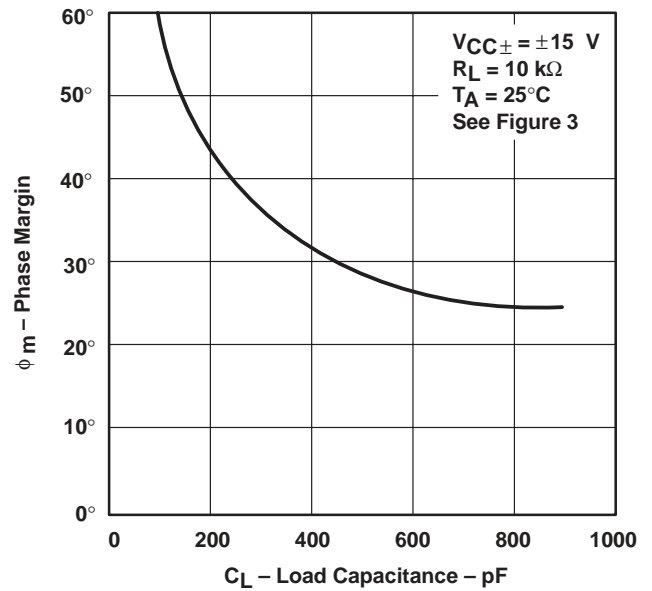

**Figure 34**

† Data applies for the amplifier block only; the switched-capacitor block is not supplying  $V_{CC-}$  supply.

**TLE2662**  
**DUAL  $\mu$ POWER JFET-INPUT OPERATIONAL AMPLIFIER**  
**WITH SWITCHED-CAPACITOR VOLTAGE CONVERTER**

SLOS118B – DECEMBER 1992 – REVISED AUGUST 1994

**TYPICAL CHARACTERISTICS†**  
**OPERATIONAL AMPLIFIER SECTION**

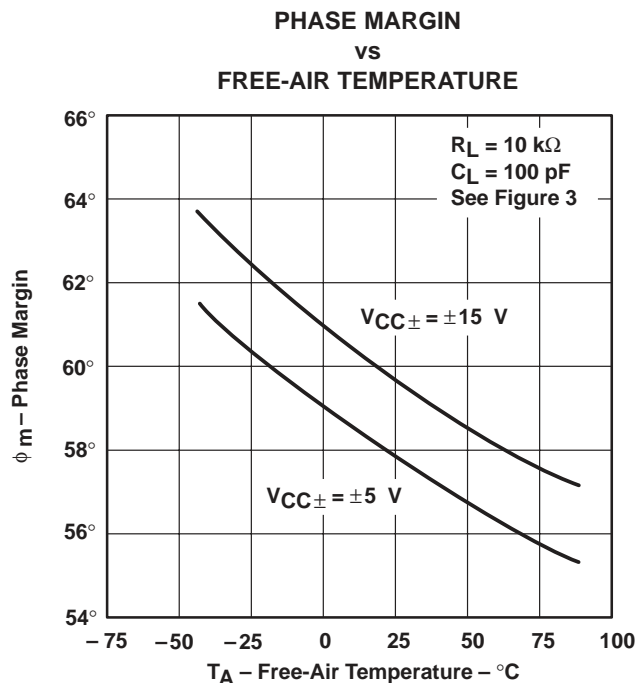

**Figure 35**

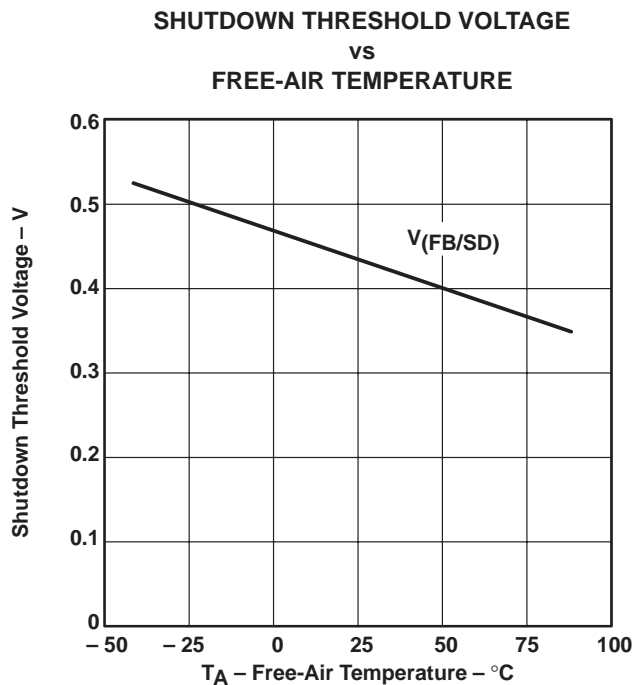

**Figure 36**

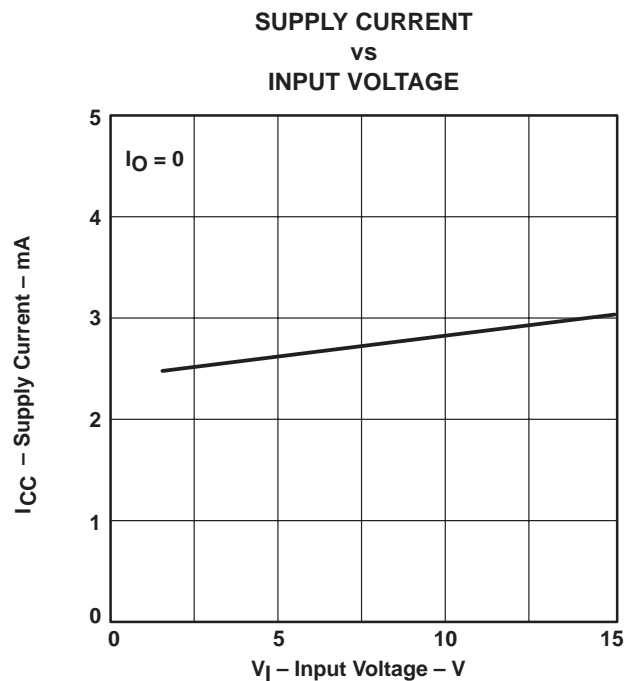

**Figure 37**

† Data applies for the amplifier block only; the switched-capacitor block is not supplying  $V_{CC-}$  supply.

**TYPICAL CHARACTERISTICS†  
 SWITCHED-CAPACITOR SECTION**

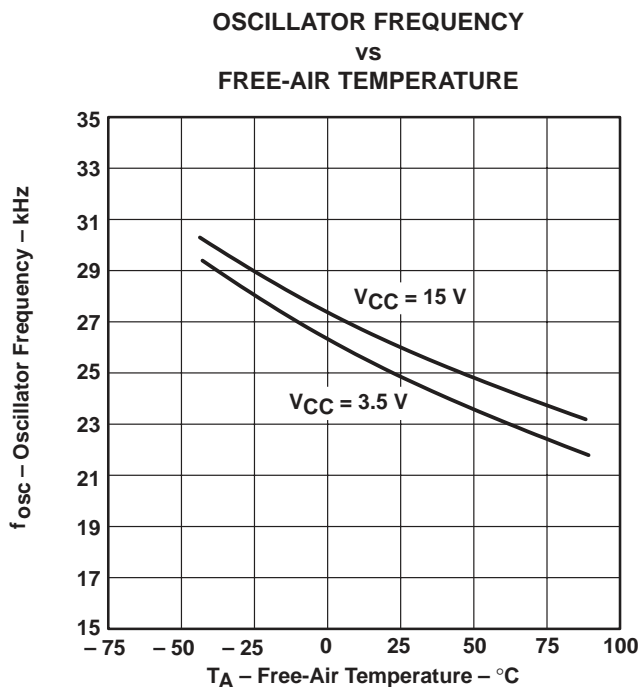

Figure 38

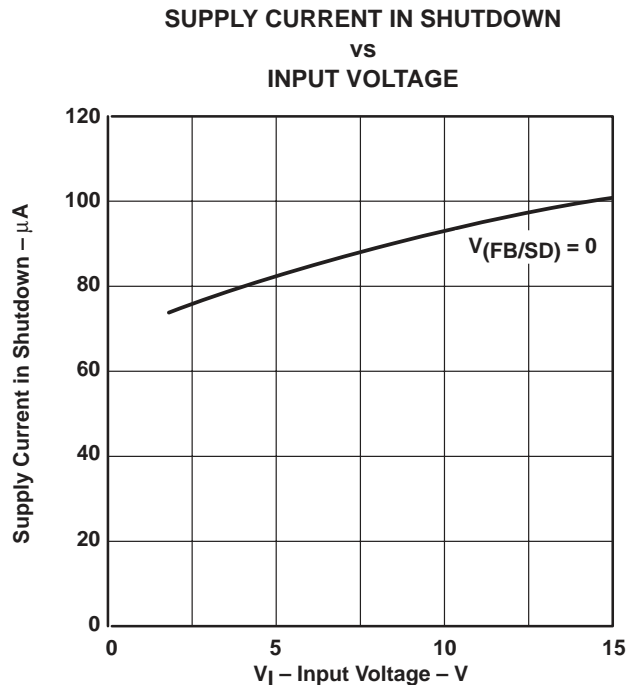

Figure 39

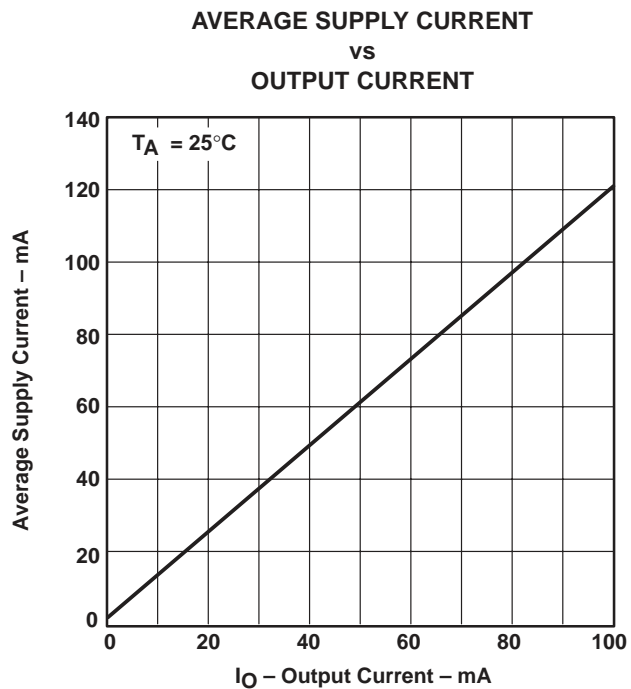

Figure 40

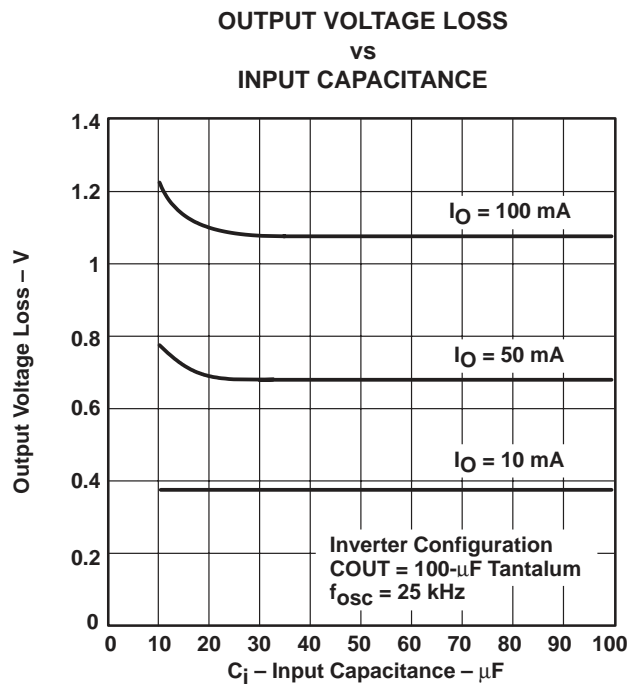

Figure 41

† Data applies for the switched-capacitor block only. Amplifier block is not connected.

**TLE2662**  
**DUAL  $\mu$ POWER JFET-INPUT OPERATIONAL AMPLIFIER**  
**WITH SWITCHED-CAPACITOR VOLTAGE CONVERTER**

SLOS118B – DECEMBER 1992 – REVISED AUGUST 1994

**TYPICAL CHARACTERISTICS†**  
**SWITCHED-CAPACITOR SECTION**

**OUTPUT VOLTAGE LOSS**  
**vs**  
**OSCILLATOR FREQUENCY**

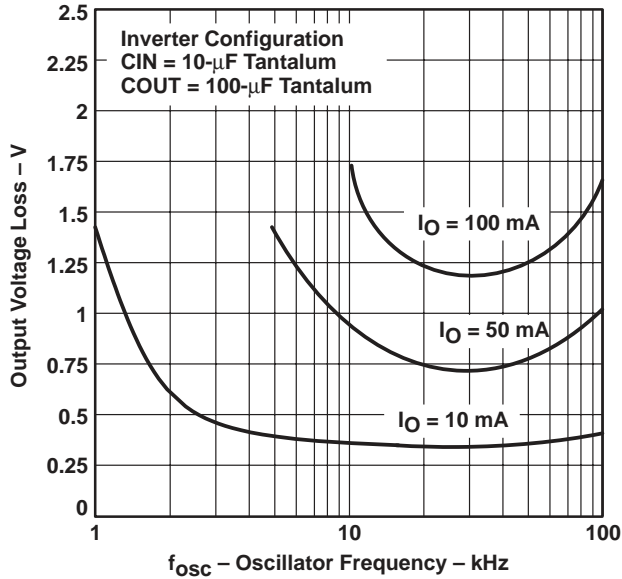

**Figure 42**

**OUTPUT VOLTAGE LOSS**  
**vs**  
**OSCILLATOR FREQUENCY**

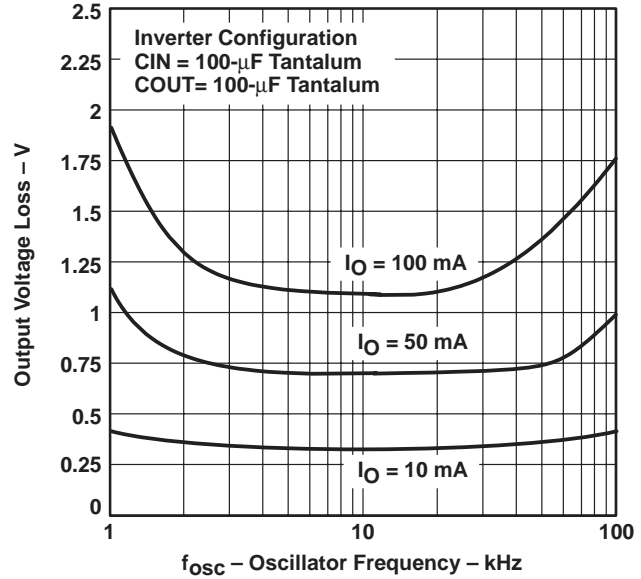

**Figure 43**

**REGULATED OUTPUT VOLTAGE**  
**vs**  
**FREE-AIR TEMPERATURE**

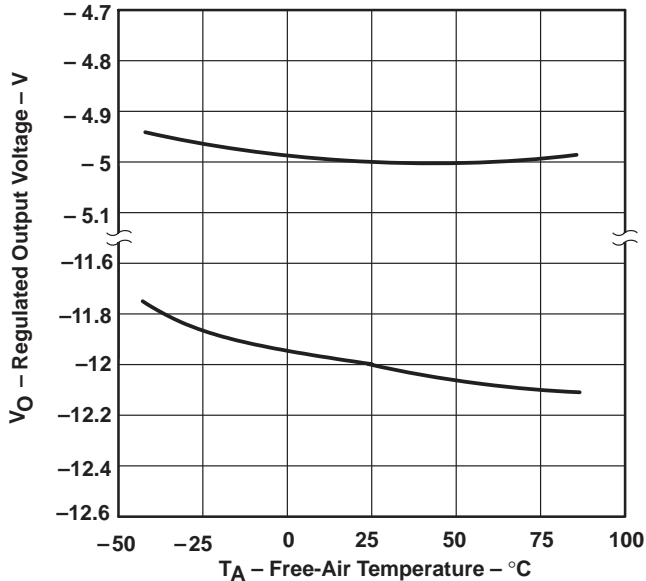

**Figure 44**

**REFERENCE VOLTAGE CHANGE**  
**vs**  
**FREE-AIR TEMPERATURE**

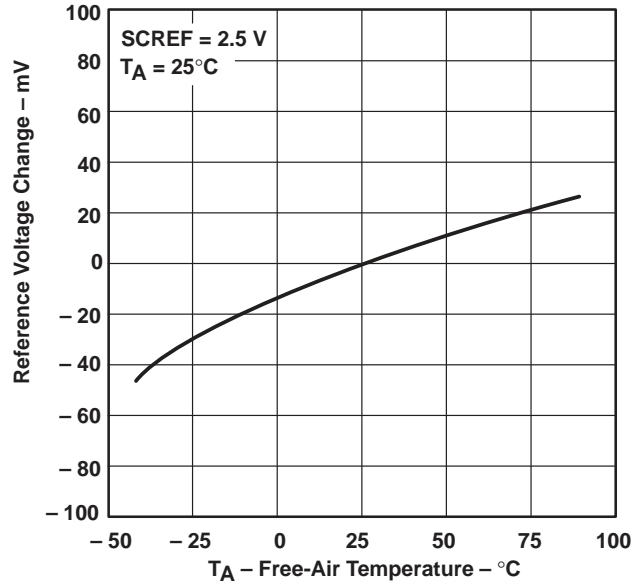

**Figure 45**

† Data applies for the switched-capacitor block only. Amplifier block is not connected.

TYPICAL CHARACTERISTICS†  
SWITCHED-CAPACITOR SECTION

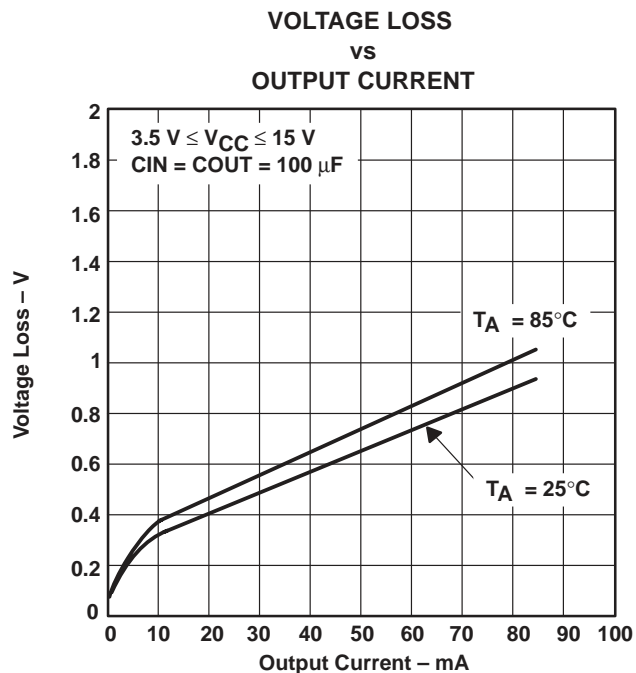

Figure 46

† Data applies for the switched-capacitor block only. Amplifier block is not connected.

**TLE2662**  
**DUAL  $\mu$ POWER JFET-INPUT OPERATIONAL AMPLIFIER**  
**WITH SWITCHED-CAPACITOR VOLTAGE CONVERTER**

SLOS118B – DECEMBER 1992 – REVISED AUGUST 1994

**APPLICATION INFORMATION**

**amplifier section**

**input characteristics**

The TLE2662 is specified with a minimum and a maximum input voltage that if exceeded at either input, could cause the device to malfunction.

Because of the extremely high input impedance and resulting low bias-current requirements, the TLE2662 operational amplifier section is well suited for low-level signal processing; however, leakage currents on printed-circuit boards and sockets can easily exceed bias-current requirements and cause degradation in system performance. It is a good practice to include guard rings around inputs (see Figure 47). These guards should be driven from a low-impedance source at the same voltage level as the common-mode input.

The inputs of any unused amplifiers should be tied to ground to avoid possible oscillation.

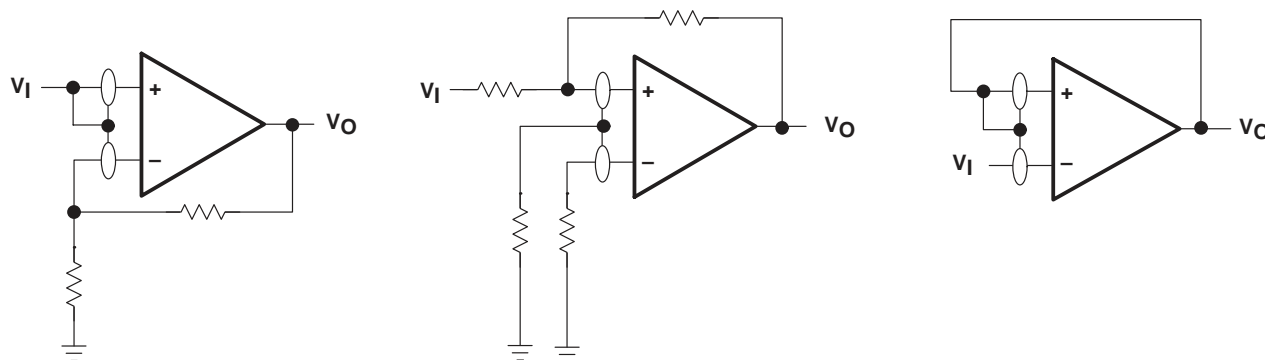

**Figure 47. Use of Guard Rings**

**switched-capacitor section**

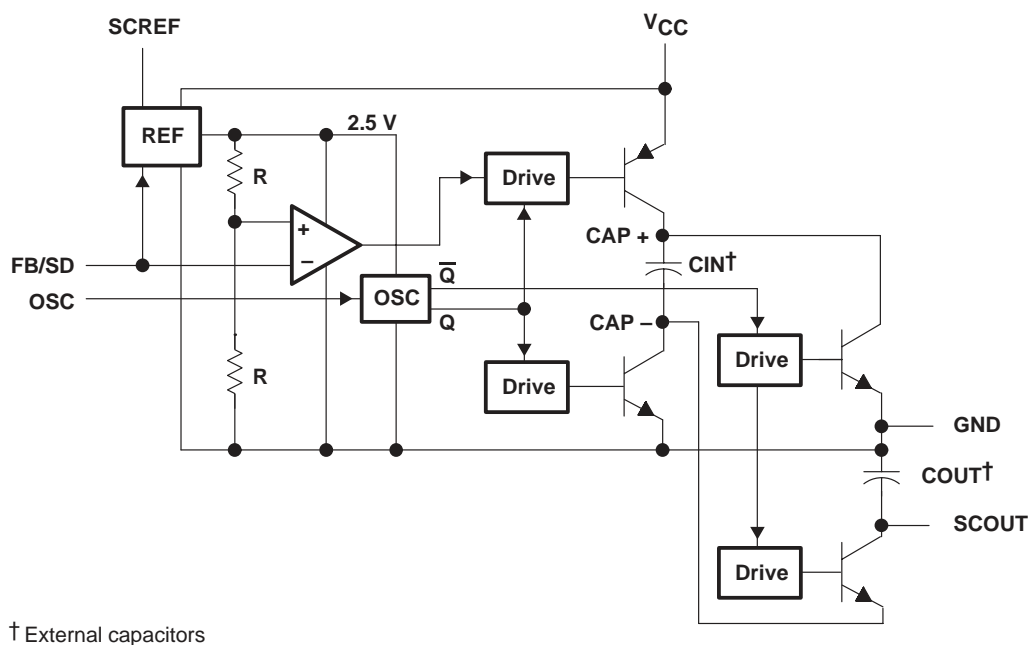

† External capacitors

**Figure 48. Functional Block Diagram for Switched-Capacitor Block Only**



## APPLICATION INFORMATION

### switched-capacitor section (continued)

The TLE2662, with its high-output-drive amplifiers and switched-capacitor voltage converter, readily lends itself to applications like headphone drivers where large signal swing into heavy loads is paramount. Another application is analog-to-digital interfacing when only a single rail is available to the system, but maximization of the ADC dynamic range is key. See Figure 48 for the functional block diagram of the switched-capacitor block.

### typical application

In its most basic configuration, the TLE2662 switched-capacitor section is used as a voltage inverter to provide the negative rail for the amplifiers in a single-supply system. As shown in Figure 49, the positive 5-V supply is connected to both  $V_{CC+}$  and SCIN.  $V_{CC-}$  is connected to the output of the charge pump, SCOUT. Only three external components (excluding the resistors used with the amplifiers) are necessary: the storage capacitors, CIN and COUT, and a fast-recovery Schottky diode to clamp SCOUT during start up. The diode is necessary because the amplifiers present a load referenced to the positive rail and tends to pull SCOUT above ground, which can cause the device to fail to start up (see pin functions section in APPLICATION INFORMATION). As shown in Figure 50, one amplifier is shown driving a resistive load; the other is interfacing to an analog-to-digital converter (ADC).

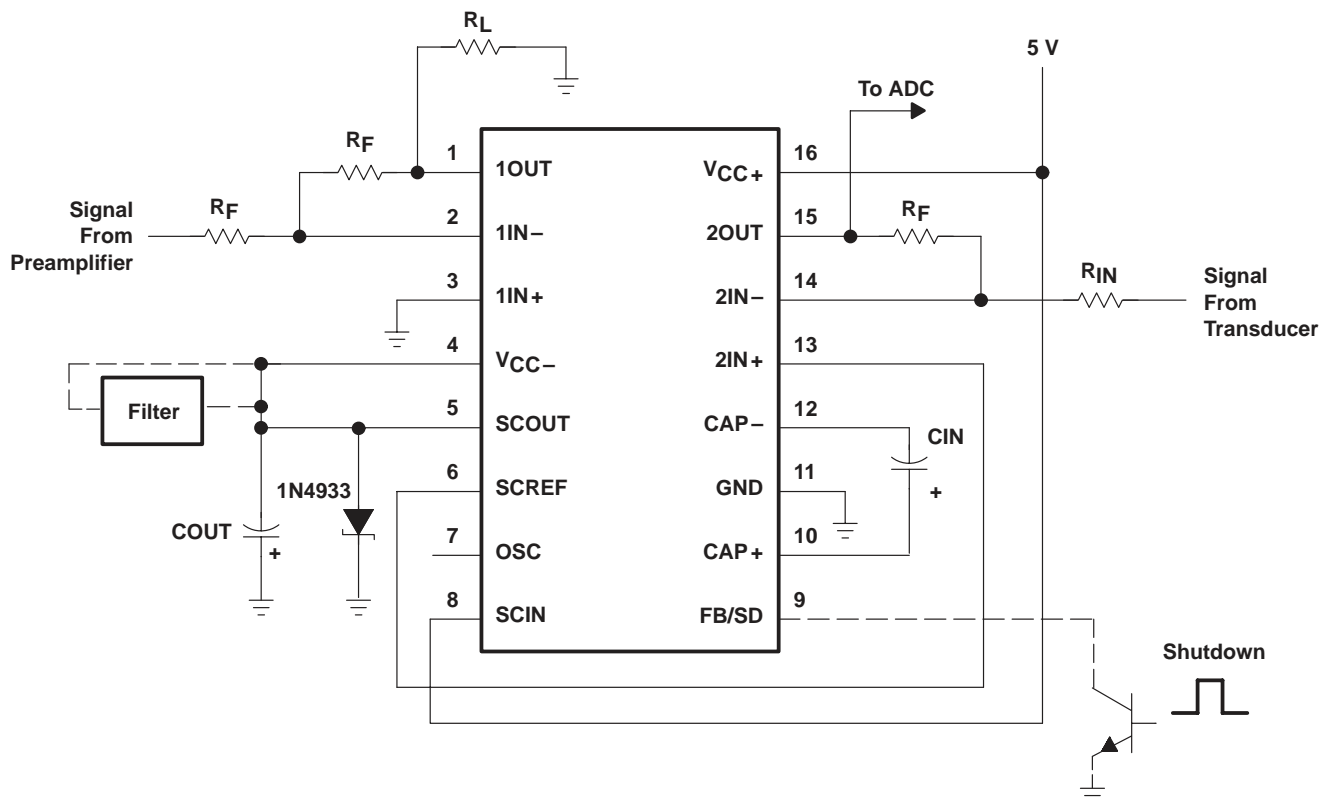

**Figure 49. Switched-Capacitor Block Supplying Negative Rail for Amplifiers**

**APPLICATION INFORMATION**

**typical application (continued)**

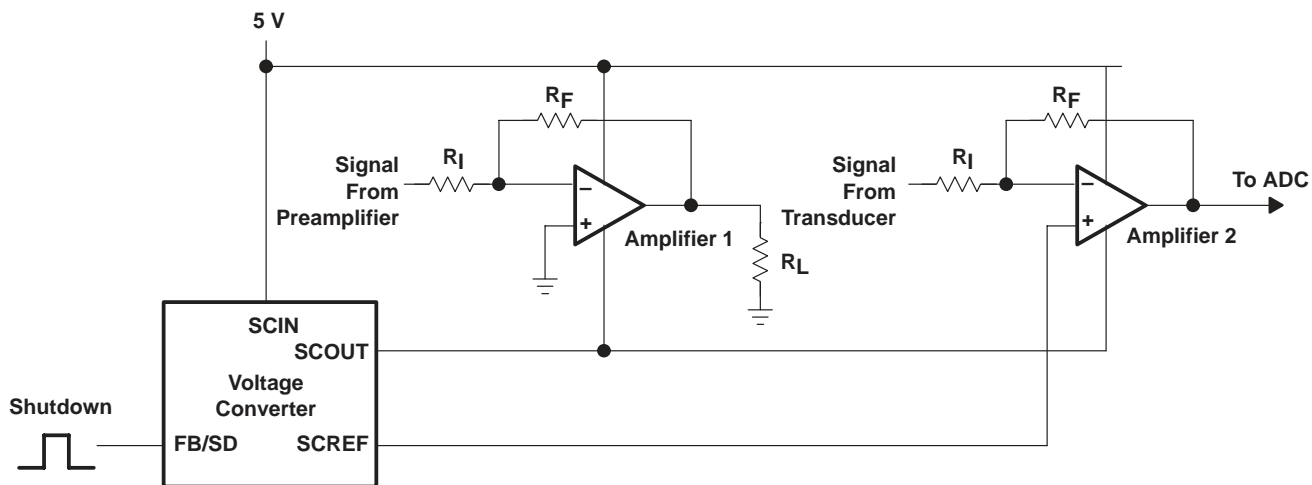
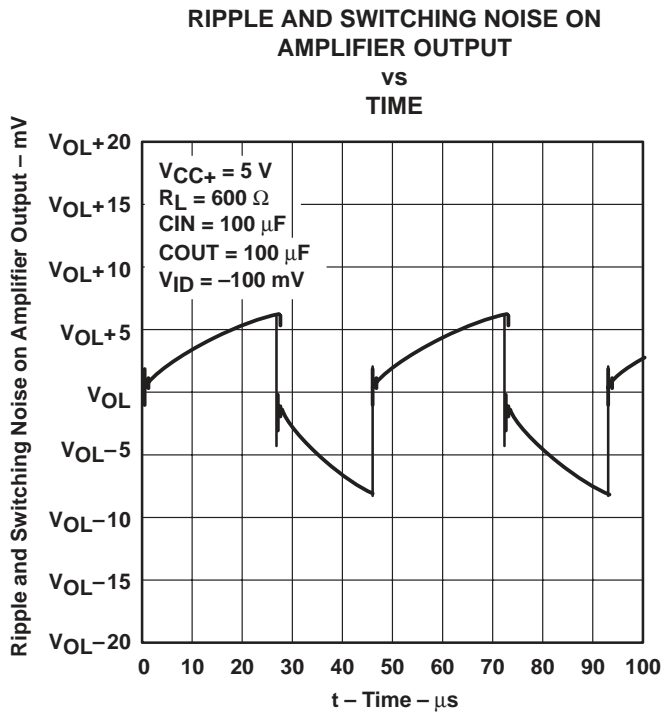
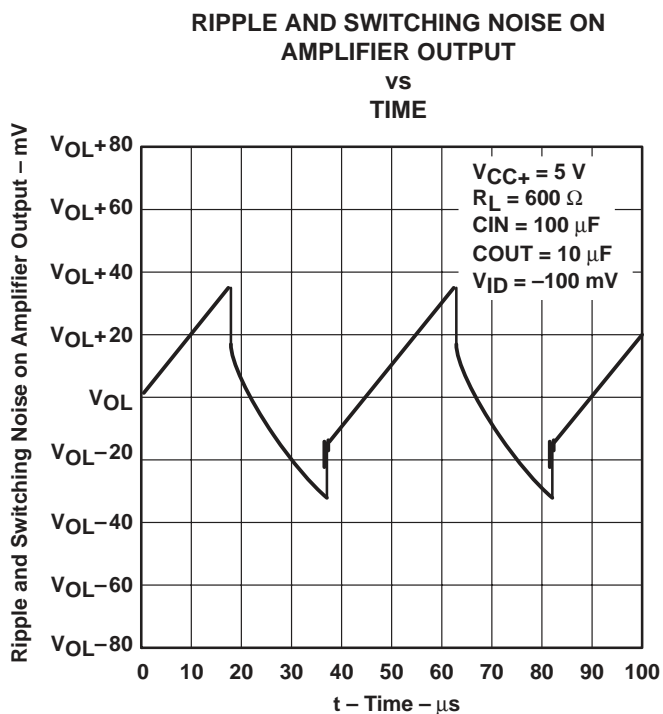

**Figure 50. Equivalent Schematic: Amplifier 1 Driving Resistive Load, Amplifier 2 Interfacing to an ADC**

Though simple, this configuration has the inherent disadvantage of having ripple and switching-noise components on SCOUT. These are coupled into the amplifier's signal path, effectively introducing distortion into the output waveform. The effect is most pronounced when the outputs are driven low, loading the negative rail generated by the charge pump. A first approach to minimizing these effects is to increase the size of COUT using a low-ESR type capacitor (refer to the switched-capacitor selection section under capacitor selection and output ripple). Figures 51 and 52 compare the ripple and noise present at the amplifier output with COUT = 10  $\mu$ F and COUT = 100  $\mu$ F, respectively, with the outputs driven low into a 600- $\Omega$  load.

**APPLICATION INFORMATION**

typical application (continued)



Additional filtering can be added between SCOUT and  $V_{CC-}$  to further reduce ripple and noise. For example, adding the simple low-pass LC filter shown in Figure 53, implemented using a 50- $\mu$ H inductor and 220- $\mu$ F capacitor (available in surface mount), results in the reduced levels of ripple and switching noise at the amplifier's outputs (see Figures 54 and 55). Larger values of L or C can be used for even better attenuation.

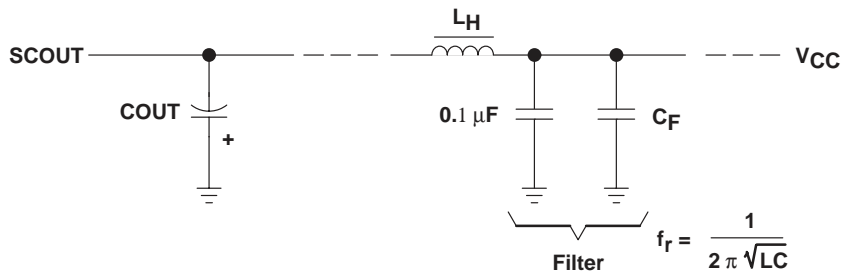

**Figure 53. LC Filter Used to Reduce Ripple and Switching Noise,  $f_r = 1/2\pi\sqrt{LC}$ ,  $A = -40$  dB Per Decade**

**TLE2662**  
**DUAL  $\mu$ POWER JFET-INPUT OPERATIONAL AMPLIFIER**  
**WITH SWITCHED-CAPACITOR VOLTAGE CONVERTER**

SLOS118B – DECEMBER 1992 – REVISED AUGUST 1994

**APPLICATION INFORMATION**

typical application (continued)

**RIPPLE AND SWITCHING NOISE ON AMPLIFIER OUTPUT**  
**VS**  
**TIME**

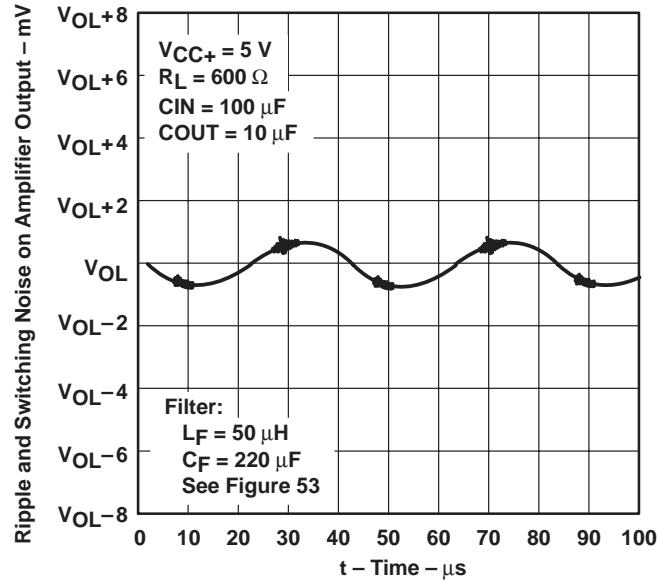

**Figure 54**

**RIPPLE AND SWITCHING NOISE ON AMPLIFIER OUTPUT**  
**VS**  
**TIME**

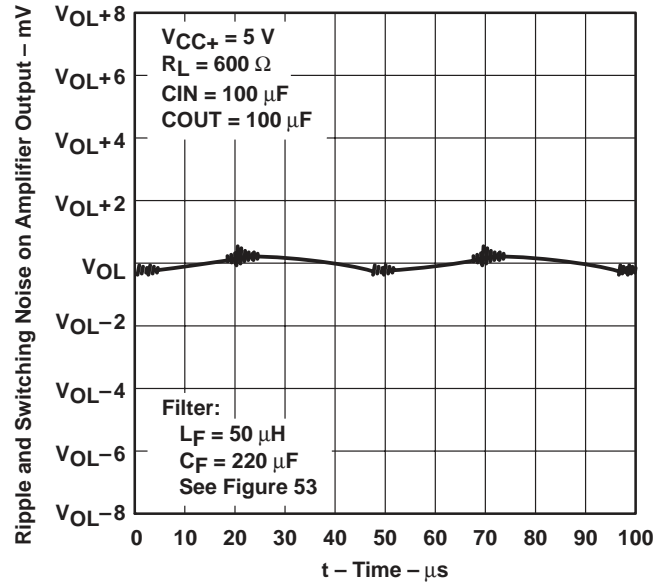
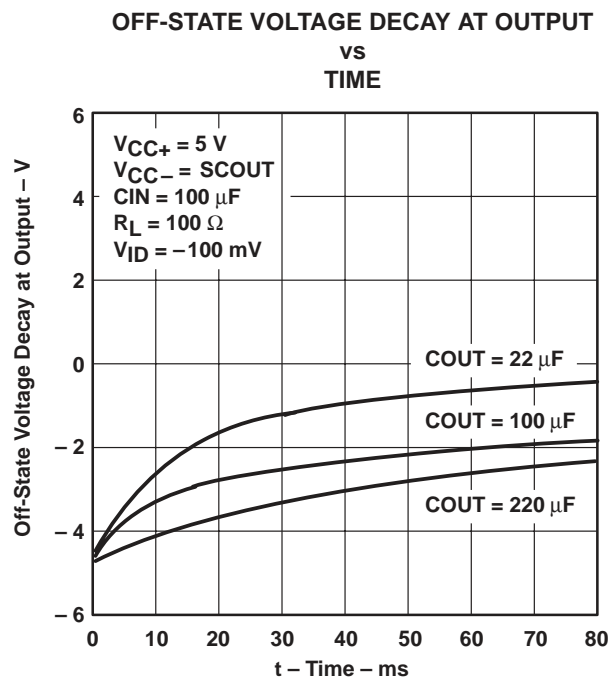

**Figure 55**

## APPLICATION INFORMATION

### precision measurement techniques

In systems where the amplifier outputs are being sampled by an analog-to-digital converter (ADC), the switched-capacitor network can be temporarily disabled by applying a voltage of less than 0.45 V to FB/SD. This is easily accomplished using any open-collector gate (shown by dashed lines in Figure 49). When disabled, the internal switches are set to dump any remaining charge onto COUT. The voltage at SCOUT decays to zero at a rate dependent on both the size of COUT and loading. During this time, the amplifier's outputs are free of any switching-induced ripple and noise. Figure 56 shows the relationship of the output voltage decay time to the size of the output storage capacitor when one channel of the amplifier is driving a 100- $\Omega$  load to ground. SCOUT rises again when the external gate is turned off (see Figure 57).



**Figure 56**

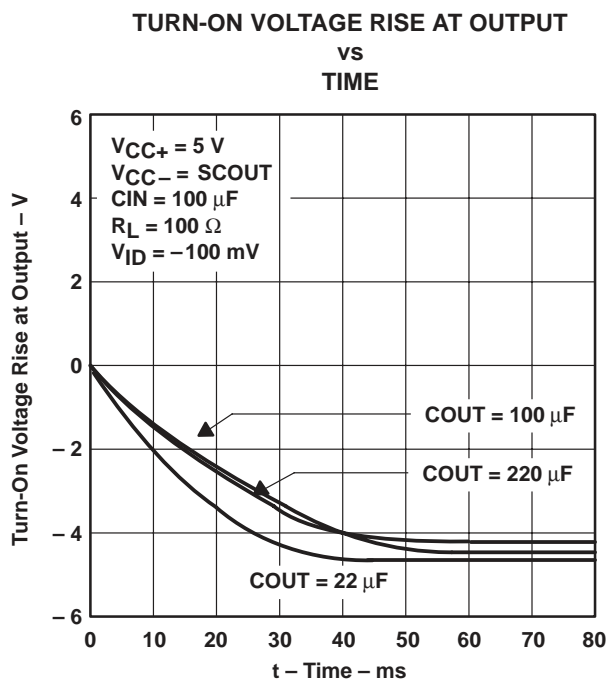

**Figure 57**

The amplifier's negative input common-mode voltage limit ( $V_{ICR-}$ ) is specified as an offset from the negative rail. Care should be taken to ensure that the input signal does not violate this limit as SCOUT decays. The negative output voltage swing is similarly affected by the gradual loss of the negative rail.

This application takes advantage of the otherwise unused SCREF output of the switched-capacitor block to bias one amplifier to 2.5 V. This is especially useful when the amplifier is followed by an ADC, keeping the signal centered in the middle of the converter dynamic range. Other biasing methods may be necessary in precision systems.

In Figure 58, SCREF, R1, and R2 are used to generate a feedback voltage to the TLE2662 error amplifier. This voltage, fed into FB/SD, is used to regulate the voltage at SCOUT. When used this way, there is higher voltage loss ( $SCIN - |SCOUT|$ ) associated with the regulation. For example, the inverter generates an unregulated voltage of approximately -4.5 V from a positive 5-V source; it can achieve a regulated output voltage of only about -3.5 V. Though this reduces the amplifier input and output dynamic range, both  $V_{ICR-}$  and  $V_{OL}$  still extend to below ground.

**TLE2662**  
**DUAL  $\mu$ POWER JFET-INPUT OPERATIONAL AMPLIFIER**  
**WITH SWITCHED-CAPACITOR VOLTAGE CONVERTER**

SLOS118B – DECEMBER 1992 – REVISED AUGUST 1994

**APPLICATION INFORMATION**

**precision measurement techniques (continued)**

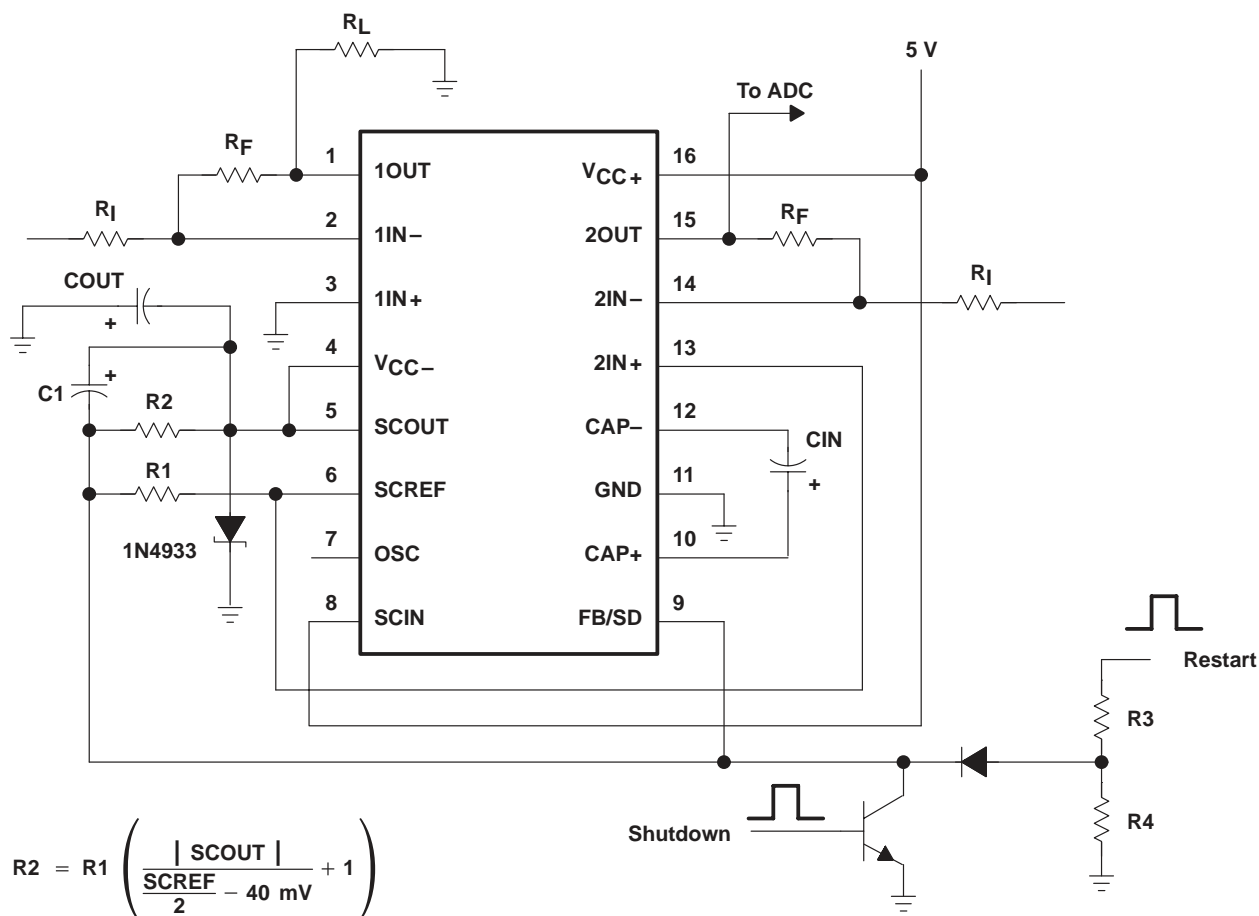

Where: SCREF = 2.5 V Nominal

**Figure 58. Voltage Inverter With Regulated Output**

The reference voltage, though being used as part of the regulation circuitry, is still available for other uses if total current drawn from it is limited to under 60  $\mu$ A. The shutdown feature also remains available, though a restart pulse may be necessary to start the switched-capacitor if the voltage on COUT is not fully discharged. This restart pulse is isolated from the feedback loop using a blocking diode in the regulation section.

The circuit designer should be aware that the TLE2662 amplifier and switched-capacitor sections are tested and specified separately. Performance may differ from that shown in the typical characteristics section when used together. This is evident, for example, in the dependence of  $V_{ICR-}$  and  $V_{OL}$  on  $V_{CC-}$ . The impact of supplying the amplifier negative rail using the switched-capacitor block in each design should be considered and carefully evaluated.

The more esoteric features of the switched-capacitor building block, including external synchronization of the internal oscillator and power dissipation considerations, are covered in detail in the following section.

## APPLICATION INFORMATION

### switched-capacitor function

A review of a basic switched-capacitor building block is helpful in understanding the operation of the TLE2662. When the switch shown in Figure 59 is in the left position, capacitor C1 charges to the voltage at V1. The total charge on C1 is  $q_1 = C_1V_1$ . When the switch is moved to the right, C1 is discharged to the voltage at V2. After this discharge time, the charge on C1 is  $q_2 = C_1V_2$ . The charge has been transferred from the source V1 to the output V2. The amount of charge transferred is as shown in equation 1.

$$\Delta q = q_1 - q_2 = C_1(V_1 - V_2) \quad (1)$$

If the switch is cycled  $f$  times per second, the charge transfer per unit time (i.e., current) is shown in equation 2.

$$I = f \times \Delta q = f \times C_1(V_1 - V_2) \quad (2)$$

To obtain an equivalent resistance for a switched-capacitor network, this equation can be rewritten in terms of voltage and impedance equivalence as shown in equation 3.

$$I = \frac{V_1 - V_2}{(1/fC_1)} = \frac{V_1 - V_2}{R_{EQUIV}} \quad (3)$$

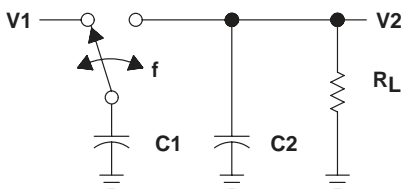
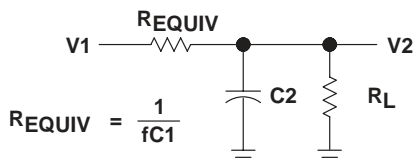

**Figure 59. Switched-Capacitor Block**

A new variable,  $R_{EQUIV}$ , is defined as  $R_{EQUIV} = 1/fC_1$ . The equivalent circuit for the switched-capacitor network is as shown in Figure 60. The TLE2662 has the same switching action as the basic switched-capacitor voltage converter. Even though this simplification does not include finite switch-on resistance and output-voltage ripple, it provides an insight into how the device operates.

These simplified circuits explain voltage loss as a function of oscillator frequency (see Figure 43). As oscillator frequency is decreased, the output impedance is eventually dominated by the  $1/fC_1$  term and voltage losses rise.

Voltage losses also rise as oscillator frequency increases. This is caused by internal switching losses that occur due to some finite charge being lost on each switching cycle. This charge loss per-unit-cycle, when multiplied by the switching frequency, becomes a current loss. At high frequency, this loss becomes significant and voltage losses again rise. The oscillator of the TLE2662 switched-capacitor section is designed to run in the frequency band where voltage losses are at a minimum.



**Figure 60. Switched-Capacitor Equivalent Circuit**

**TLE2662**  
**DUAL  $\mu$ POWER JFET-INPUT OPERATIONAL AMPLIFIER**  
**WITH SWITCHED-CAPACITOR VOLTAGE CONVERTER**

SLOS118B – DECEMBER 1992 – REVISED AUGUST 1994

**APPLICATION INFORMATION**

**pin functions (see functional block diagram – converter)**

Supply voltage (SCIN) alternately charges CIN to the input voltage when CIN is switched in parallel with the input supply, and then transfers charge to COUT when CIN is switched in parallel with COUT. Switching occurs at the oscillator frequency. During the time that CIN is charging, the peak supply current is approximately 2.2 times the output current. During the time that CIN is delivering a charge to COUT, the supply current drops to approximately 0.2 times the output current. An input supply bypass capacitor supplies part of the peak input current drawn by the TLE2662 switched-capacitor section and averages out the current drawn from the supply. A minimum input supply bypass capacitor of 2  $\mu$ F, preferably tantalum or some other low-ESR type, is recommended. A larger capacitor is desirable in some cases. An example is when the actual input supply is connected to the TLE2662 through long leads or when the pulse currents drawn by the TLE2662 might affect other circuits through supply coupling.

In addition to being the output pin, SCOUT is tied to the substrate of the device. Special care must be taken in TLE2662 circuits to avoid making SCOUT positive with respect to any of the other pins. For circuits with the output load connected from  $V_{CC+}$  to SCOUT or from some external positive supply voltage to SCOUT, an external Schottky diode must be added (see Figure 61). This diode prevents SCOUT from being pulled above the GND during start up. A fast-recovery diode such as IN4933 with low forward voltage ( $V_f \approx 0.2$  V) can be used.

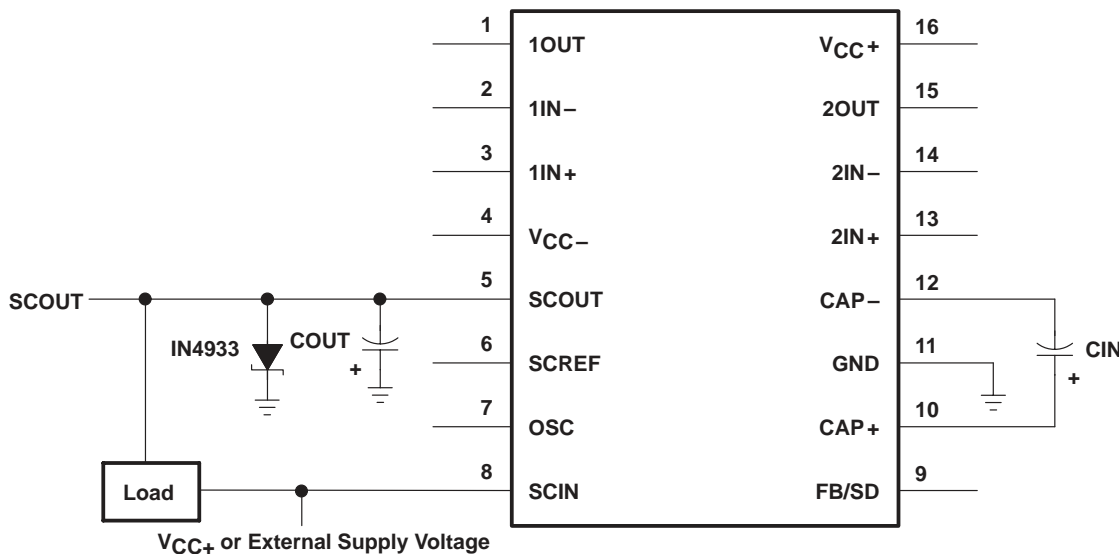

**Figure 61. Circuit With Load Connected From  $V_{CC}$  to SCOUT**

The voltage reference (SCREF) output provides a 2.5-V reference point for use in TLE2662-based regulator circuits. The temperature coefficient (TC) of the reference voltage has been adjusted so that the TC of the regulated output voltage is near zero. As seen in the typical performance curves, this requires the reference output to have a positive TC. This nonzero drift is necessary to offset a drift term inherent in the internal reference divider and comparator network tied to the feedback pin. The overall result of these drift terms is a regulated output that has a slight positive TC at output voltages below 5 V and a slight negative TC at output voltages above 5 V. For regulator-feedback networks, reference output current should be limited to approximately 60  $\mu$ A. SCREF draws approximately 100  $\mu$ A when shorted to ground and does not affect the internal reference/regulator. This pin can also be used as a pullup for TLE2662 circuits that require synchronization.



## APPLICATION INFORMATION

### pin functions (continued)

CAP+ is the positive side of input capacitor (CIN) and is alternately driven between  $V_{CC}$  and ground. When driven to  $V_{CC}$ , CAP+ sources current from  $V_{CC}$ . When driven to ground, CAP+ sinks current to ground. CAP– is the negative side of the input capacitor and is driven alternately between ground and SCOUT. When driven to ground, CAP– sinks current to ground. When driven to SCOUT, CAP– sources current from COUT. In all cases, current flow in the switches is unidirectional as should be expected when using bipolar switches.

OSC can be used to raise or lower the oscillator frequency or to synchronize the device to an external clock. Internally, OSC is connected to the oscillator timing capacitor ( $C_t \approx 150$  pF), which is alternately charged and discharged by current sources of  $\pm 7$   $\mu$ A, so that the duty cycle is approximately 50%. The TLE2662 switched-capacitor section oscillator is designed to run in the frequency band where switching losses are minimized. However, the frequency can be raised, lowered, or synchronized to an external system clock if necessary.

The frequency can be increased by adding an external capacitor (C2 in Figure 62) in the range of 5 pF–20 pF from CAP+ to OSC. This capacitor couples a charge into  $C_t$  at the switch transitions. This shortens the charge and discharge time and raises the oscillator frequency. Synchronization can be accomplished by adding an external pullup resistor from OSC to SCREF. A 20-k $\Omega$  pullup resistor is recommended. An open-collector gate or an npn transistor can then be used to drive OSC at the external clock frequency as shown in Figure 62. The frequency can be lowered by adding an external capacitor ( $C_1$  in Figure 62) from OSC to ground. This increases the charge and discharge times, which lowers the oscillator frequency.

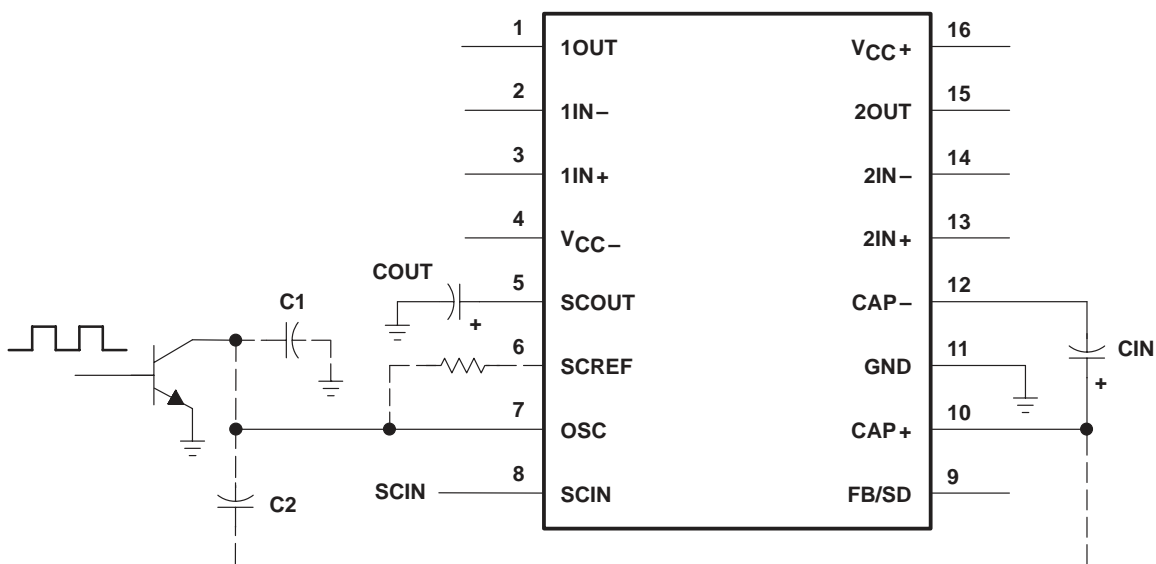

**Figure 62. External Clock System**

The feedback/shutdown (FB/SD) pin has two functions. Pulling FB/SD below the shutdown threshold ( $\approx 0.45$  V) puts the device into shutdown. In shutdown, the reference/regulator is turned off and switching stops. The switches are set such that both CIN and COUT are discharged through the output load. Quiescent current in shutdown drops to approximately 100  $\mu$ A. Any open-collector gate can be used to put the TLE2662 into shutdown. For normal (unregulated) operation, the device restarts when the external gate is shut off. In TLE2662 circuits that use the regulation feature, the external resistor divider can provide enough pulldown to keep the device in shutdown until the output capacitor (COUT) has fully discharged. For most applications

# TLE2662 DUAL $\mu$ POWER JFET-INPUT OPERATIONAL AMPLIFIER WITH SWITCHED-CAPACITOR VOLTAGE CONVERTER

SLOS118B – DECEMBER 1992 – REVISED AUGUST 1994

## APPLICATION INFORMATION

where the TLE2662 is run intermittently, this does not present a problem because the discharge time of the output capacitor is short compared to the off time of the device. In applications where the device has to start-up before the output capacitor (COUT) has fully discharged, a restart pulse must be applied to FB/SD of the TLE2662.

Using the circuit shown in Figure 63, the restart signal can be either a pulse ( $t_p > 100 \mu s$ ) or a logic high. Diode coupling the restart signal into FB/SD allows the output voltage to rise and regulate without overshoot. The resistor divider R3/R4 shown in Figure 63 should be chosen to provide a signal level at FB/SD of 0.7 V–1.1 V. FB/SD is also the inverting input of the TLE2662 switched-capacitor section error amplifier, and as such can be used to obtain a regulated output voltage.

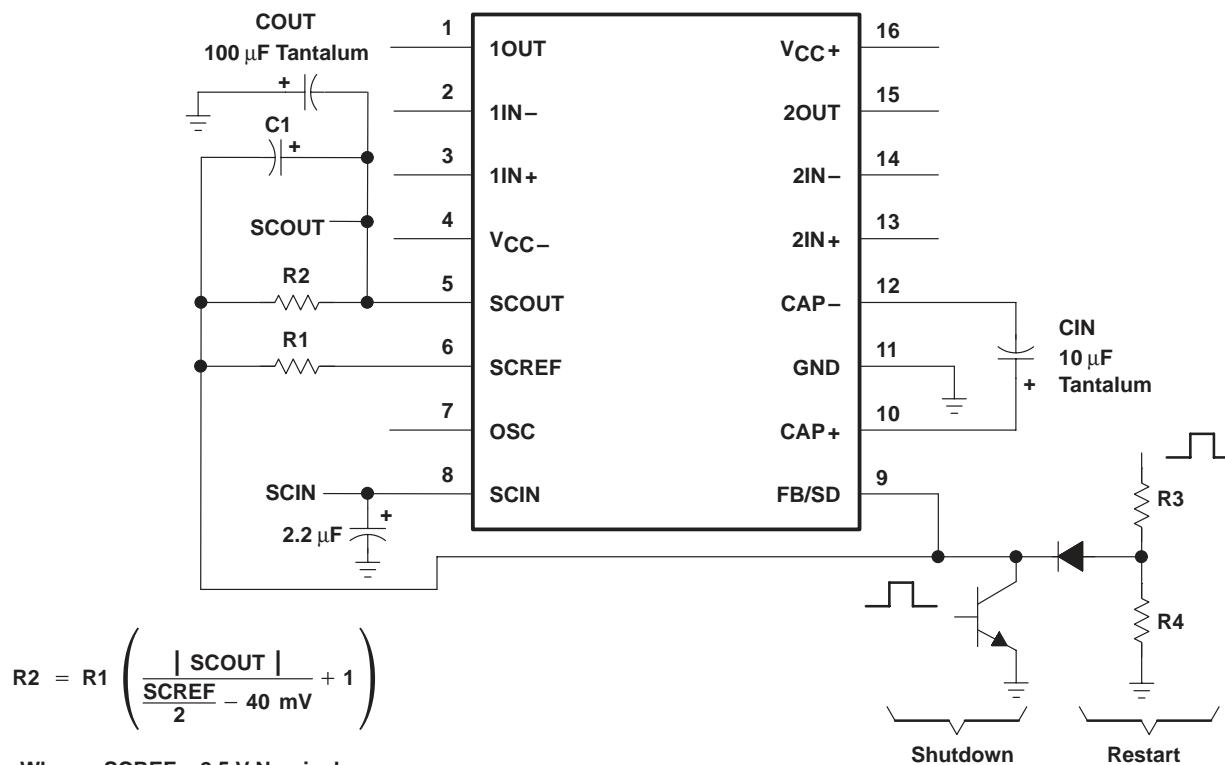

Figure 63. Basic Regulation Configuration

### regulation

The error amplifier of the TLE2662 switched-capacitor section drives the npn switch to control the voltage across the input capacitor (CIN), which determines the output voltage. When the reference and error amplifier of the TLE2662 is used, an external resistive divider is all that is needed to set the regulated output voltage. Figure 63 shows the basic regulator configuration and the formula for calculating the appropriate resistor values. R1 should be 20 k $\Omega$  or greater because the reference current is limited to  $\pm 100 \mu A$ . R2 should be in the range of 100 k $\Omega$  to 300 k $\Omega$ . Frequency compensation is accomplished by adjusting the ratio of CIN to COUT. For best results, this ratio should be approximately 1 to 10. Capacitor C1, required for good load regulation, should be 0.002  $\mu F$  for all output voltages.

## APPLICATION INFORMATION

### regulation (continued)

The functional block diagram shows that the maximum regulated output voltage is limited by the supply voltage. For the basic configuration, |SCOUT| referenced to GND of the TLE2662 must be less than the total of the supply voltage minus the voltage loss due to the switches. The voltage loss versus output current due to the switches can be found in the typical performance curves.

### capacitor selection

While the exact values of CIN and COUT are noncritical, good-quality low-ESR capacitors such as solid tantalum are necessary to minimize voltage losses at high currents. For CIN, the effect of the equivalent series resistance (ESR) of the capacitor is multiplied by four, since switch currents are approximately two times higher than output current. Losses occur on both the charge and discharge cycle, which means that a capacitor with 1  $\Omega$  of ESR for CIN has the same effect as increasing the output impedance of the switched-capacitor section by 4  $\Omega$ . This represents a significant increase in the voltage losses. COUT is alternately charged and discharged at a current approximately equal to the output current. The ESR of the capacitor causes a step function to occur in the output ripple at the switch transitions. This step function degrades the output regulation for changes in output load current and should be avoided. A technique used is to parallel a smaller tantalum capacitor with a large aluminum electrolytic capacitor to gain both low ESR and reasonable cost.

### output ripple

The peak-to-peak output ripple is determined by the output capacitor and the output current values. Peak-to-peak output ripple is approximated as shown in equation 4:

$$\Delta V = \frac{I_O}{2 f C_O} \quad (4)$$

where:

$\Delta V$  = peak-to-peak ripple  
 $f_{OSC}$  = oscillator frequency

For output capacitors with significant ESR, a second term must be added to account for the voltage step at the switch transitions. This step is approximately equal to equation 5:

$$(2I_O) (\text{ESR of } C_O) \quad (5)$$

### power dissipation (switched-capacitor section only)

The power dissipation of any TLE2662 circuit must be limited so that the junction temperature of the device does not exceed the maximum junction temperature ratings. The total power dissipation is calculated from two components, the power loss due to voltage drops in the switches, and the power loss due to drive current losses. The total power dissipated by the TLE2662 is calculated as shown in equation 6:

$$P \approx (V_{CC} - |V_O|) I_O + (V_{CC}) (I_O) \quad (6)$$

where both  $V_{CC}$  and SCOUT refer to GND. The power dissipation is equivalent to that of a linear regulator. Due to limitations of the DW package, steps must be taken to dissipate power externally for large input or output differentials. This is accomplished by placing a resistor in series with CIN as shown in Figure 64. A portion of the input voltage is dropped across this resistor without affecting the output regulation. Since switch current is approximately 2.2 times the output current and the resistor causes a voltage drop when CIN is both charging and discharging, the resistor chosen is as shown in equation 7.

**TLE2662**  
**DUAL  $\mu$ POWER JFET-INPUT OPERATIONAL AMPLIFIER**  
**WITH SWITCHED-CAPACITOR VOLTAGE CONVERTER**

SLOS118B – DECEMBER 1992 – REVISED AUGUST 1994

**APPLICATION INFORMATION**

**power dissipation (continued)**

$$R_X = V_X / (4.4 I_O) \tag{7}$$

where:

$$V_X \approx V_{CC-} - \left[ (\text{TLE2662 voltage loss}) (1.3) + |V_O| \right]$$

and  $I_{OUT}$  = maximum required output current. The factor of 1.3 allows some operating margin for the TLE2662.

When using a 12-V to -5-V converter at 100-mA output current, calculate the power dissipation without an external resistor as shown in equation 8.

$$P = (12 \text{ V} - | -5 \text{ V} |) (100 \text{ mA}) + (12 \text{ V}) (100 \text{ mA}) (0.2) \tag{8}$$

$$P = 700 \text{ mW} + 240 \text{ mW} = 940 \text{ mW}$$

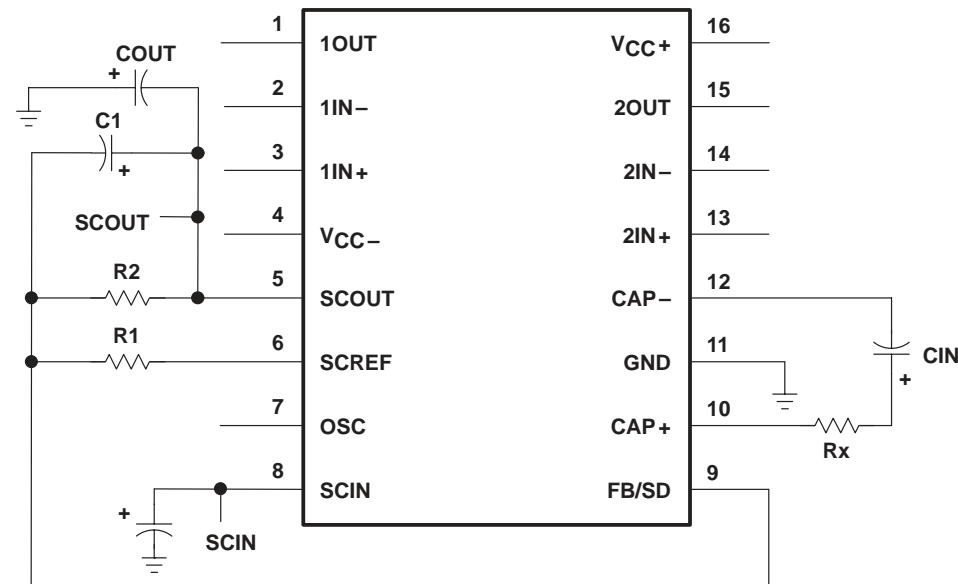

**Figure 64. Power-Dissipation-Limiting Resistor in Series With CIN**

At  $\theta_{JA}$  of 130°C/W for a commercial plastic device, a junction temperature rise of 122°C is seen. The device exceeds the maximum junction temperature at an ambient temperature of 25°C. To calculate the power dissipation with an external-resistor ( $R_X$ ), determine how much voltage can be dropped across  $R_X$ . The maximum voltage loss of the TLE2662 in the standard regulator configuration at 100 mA output current is 1.6 V (see equation 9).

$$V_X = 12 \text{ V} - \left[ (1.6 \text{ V}) (1.3) + | -5 \text{ V} | \right] = 4.9 \text{ V} \tag{9}$$

and

$$R_X = 4.9 \text{ V} / (4.4) (100 \text{ mA}) = 11 \Omega$$

## APPLICATION INFORMATION

### power dissipation (continued)

The resistor reduces the power dissipated by the TLE2662 by  $(4.9 \text{ V}) (100 \text{ mA}) = 490 \text{ mW}$ . The total power dissipated by the TLE2662 is equal to  $(940 \text{ mW} - 490 \text{ mW}) = 450 \text{ mW}$ . The junction temperature rise is  $58^\circ\text{C}$ . Although commercial devices are functional up to a junction temperature of  $125^\circ\text{C}$ , the specifications are tested to a junction temperature of  $100^\circ\text{C}$ . In this example, this means limiting the ambient temperature to  $42^\circ\text{C}$ . To allow higher ambient temperatures, the thermal resistance numbers for the TLE2662 packages represent worst-case numbers with no heat sinking and still air. Small clip-on heat sinks can be used to lower the thermal resistance of the TLE2662 package. Airflow in some systems helps to lower the thermal resistance. Wide PC board traces from the TLE2662 leads helps to remove heat from the device. This is especially true for plastic packages.

### basic voltage inverter

The switched-capacitor block is connected as a basic voltage inverter with regulation as shown in Figure 65. The magnitude of SCIN must exceed that of the desired SCOUT to accommodate voltage losses due to switching and regulation. Losses of 1 V to 2 V are typical.

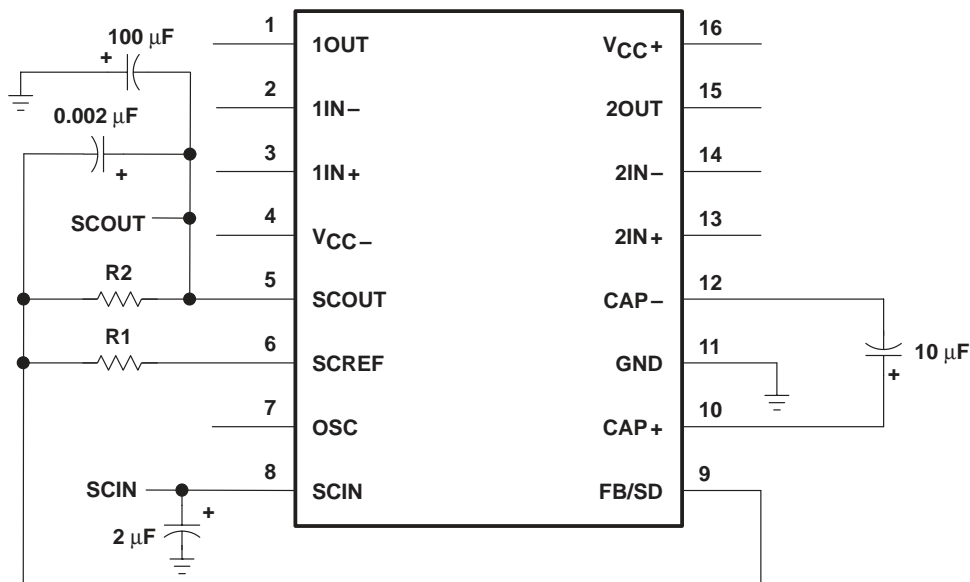

$$R2 = R1 \left( \frac{|SCOUT|}{\frac{SCREF}{2} - 40 \text{ mV}} + 1 \right) = R1 \left( \frac{|SCOUT|}{1.121 \text{ V}} + 1 \right)$$

**Figure 65. Basic Voltage Inverter/Regulator**

**TLE2662**  
**DUAL  $\mu$ POWER JFET-INPUT OPERATIONAL AMPLIFIER**  
**WITH SWITCHED-CAPACITOR VOLTAGE CONVERTER**

SLOS118B – DECEMBER 1992 – REVISED AUGUST 1994

**APPLICATION INFORMATION**

**positive voltage doubler**

In this configuration (see Figure 66), the voltage converter is configured as a positive voltage doubler providing a higher positive rail, approximately 9 V for the amplifiers or other external circuitry. Filtering (not shown) of the output of the doubler may be necessary.

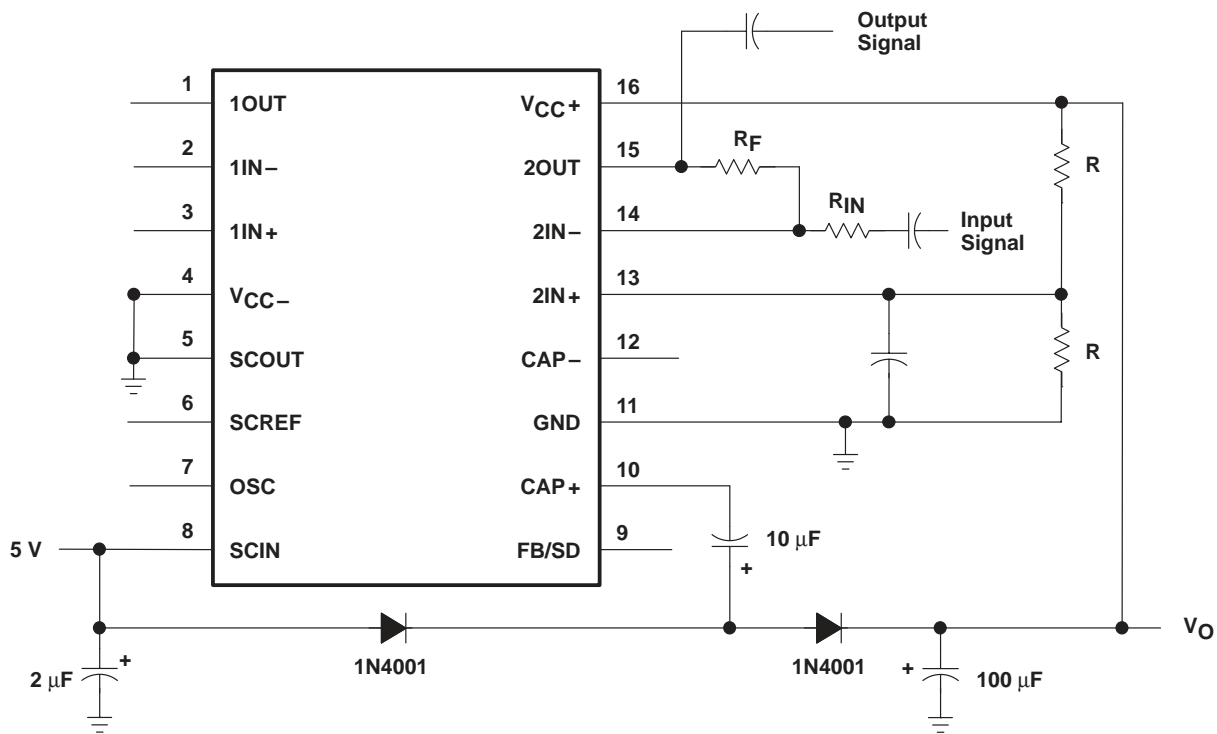

**Figure 66. Voltage Converter Configured as Positive Doubler**

**PACKAGING INFORMATION**

Orderable Device	Status <sup>(1)</sup>	Package Type	Package Drawing	Pins	Package Qty	Eco Plan <sup>(2)</sup>	Lead/Ball Finish	MSL Peak Temp <sup>(3)</sup>
TLE2662IDW	OBSOLETE	SOIC	DW	16		TBD	Call TI	Call TI
TLE2662IDWR	OBSOLETE	SOIC	DW	16		TBD	Call TI	Call TI

<sup>(1)</sup> The marketing status values are defined as follows:

**ACTIVE:** Product device recommended for new designs.

**LIFEBUY:** TI has announced that the device will be discontinued, and a lifetime-buy period is in effect.

**NRND:** Not recommended for new designs. Device is in production to support existing customers, but TI does not recommend using this part in a new design.

**PREVIEW:** Device has been announced but is not in production. Samples may or may not be available.

**OBSOLETE:** TI has discontinued the production of the device.

<sup>(2)</sup> Eco Plan - The planned eco-friendly classification: Pb-Free (RoHS) or Green (RoHS & no Sb/Br) - please check <http://www.ti.com/productcontent> for the latest availability information and additional product content details.

**TBD:** The Pb-Free/Green conversion plan has not been defined.

**Pb-Free (RoHS):** TI's terms "Lead-Free" or "Pb-Free" mean semiconductor products that are compatible with the current RoHS requirements for all 6 substances, including the requirement that lead not exceed 0.1% by weight in homogeneous materials. Where designed to be soldered at high temperatures, TI Pb-Free products are suitable for use in specified lead-free processes.

**Green (RoHS & no Sb/Br):** TI defines "Green" to mean Pb-Free (RoHS compatible), and free of Bromine (Br) and Antimony (Sb) based flame retardants (Br or Sb do not exceed 0.1% by weight in homogeneous material)

<sup>(3)</sup> MSL, Peak Temp. -- The Moisture Sensitivity Level rating according to the JEDEC industry standard classifications, and peak solder temperature.

**Important Information and Disclaimer:**The information provided on this page represents TI's knowledge and belief as of the date that it is provided. TI bases its knowledge and belief on information provided by third parties, and makes no representation or warranty as to the accuracy of such information. Efforts are underway to better integrate information from third parties. TI has taken and continues to take reasonable steps to provide representative and accurate information but may not have conducted destructive testing or chemical analysis on incoming materials and chemicals. TI and TI suppliers consider certain information to be proprietary, and thus CAS numbers and other limited information may not be available for release.

In no event shall TI's liability arising out of such information exceed the total purchase price of the TI part(s) at issue in this document sold by TI to Customer on an annual basis.

## IMPORTANT NOTICE

Texas Instruments Incorporated and its subsidiaries (TI) reserve the right to make corrections, modifications, enhancements, improvements, and other changes to its products and services at any time and to discontinue any product or service without notice. Customers should obtain the latest relevant information before placing orders and should verify that such information is current and complete. All products are sold subject to TI's terms and conditions of sale supplied at the time of order acknowledgment.

TI warrants performance of its hardware products to the specifications applicable at the time of sale in accordance with TI's standard warranty. Testing and other quality control techniques are used to the extent TI deems necessary to support this warranty. Except where mandated by government requirements, testing of all parameters of each product is not necessarily performed.

TI assumes no liability for applications assistance or customer product design. Customers are responsible for their products and applications using TI components. To minimize the risks associated with customer products and applications, customers should provide adequate design and operating safeguards.

TI does not warrant or represent that any license, either express or implied, is granted under any TI patent right, copyright, mask work right, or other TI intellectual property right relating to any combination, machine, or process in which TI products or services are used. Information published by TI regarding third-party products or services does not constitute a license from TI to use such products or services or a warranty or endorsement thereof. Use of such information may require a license from a third party under the patents or other intellectual property of the third party, or a license from TI under the patents or other intellectual property of TI.

Reproduction of information in TI data books or data sheets is permissible only if reproduction is without alteration and is accompanied by all associated warranties, conditions, limitations, and notices. Reproduction of this information with alteration is an unfair and deceptive business practice. TI is not responsible or liable for such altered documentation.

Resale of TI products or services with statements different from or beyond the parameters stated by TI for that product or service voids all express and any implied warranties for the associated TI product or service and is an unfair and deceptive business practice. TI is not responsible or liable for any such statements.

Following are URLs where you can obtain information on other Texas Instruments products and application solutions:

<b>Products</b>		<b>Applications</b>	
Amplifiers	<a href="http://amplifier.ti.com">amplifier.ti.com</a>	Audio	<a href="http://www.ti.com/audio">www.ti.com/audio</a>
Data Converters	<a href="http://dataconverter.ti.com">dataconverter.ti.com</a>	Automotive	<a href="http://www.ti.com/automotive">www.ti.com/automotive</a>
DSP	<a href="http://dsp.ti.com">dsp.ti.com</a>	Broadband	<a href="http://www.ti.com/broadband">www.ti.com/broadband</a>
Interface	<a href="http://interface.ti.com">interface.ti.com</a>	Digital Control	<a href="http://www.ti.com/digitalcontrol">www.ti.com/digitalcontrol</a>
Logic	<a href="http://logic.ti.com">logic.ti.com</a>	Military	<a href="http://www.ti.com/military">www.ti.com/military</a>
Power Mgmt	<a href="http://power.ti.com">power.ti.com</a>	Optical Networking	<a href="http://www.ti.com/opticalnetwork">www.ti.com/opticalnetwork</a>
Microcontrollers	<a href="http://microcontroller.ti.com">microcontroller.ti.com</a>	Security	<a href="http://www.ti.com/security">www.ti.com/security</a>
		Telephony	<a href="http://www.ti.com/telephony">www.ti.com/telephony</a>
		Video & Imaging	<a href="http://www.ti.com/video">www.ti.com/video</a>
		Wireless	<a href="http://www.ti.com/wireless">www.ti.com/wireless</a>

Mailing Address: Texas Instruments  
Post Office Box 655303 Dallas, Texas 75265