

This document is the property of Amphenol Corporation and is delivered on the express condition that it is not to be disclosed, reproduced or used, in whole or in part, for manufacture or sale by anyone other than Amphenol Corporation without its prior consent, and that no right is granted to disclose or to use any information in this document.

The marking on this product doesn't contain environmental hazardous materials per directive 2011/65/EU & 2015/863/EU for RoHS compliant and per IEC 61249-2-21 for Halogen-Free compliant.

**FOR REFERENCE ONLY**



REVISIONS				
SYM	ECN No.	DESCRIPTION	DATE	APPROVED
B	NE-10163	ADDED CAP	10/13/2010	Arron Lin
C	NE-11092	MODIFIED DRAWING	06/28/2011	Arron Lin
D	NE-15087	ADDED SOLDER PAD RECOMMENDED	07/28/2015	Roger Tsai
E	NE-18149	ADDED SERIES PACKAGING, REMOVED POS.40~80	07/20/2018	Roger Tsai
F	NE-19015	UPDATED COPLANARITY, REMOVED POS.28~38	09/26/2019	Roger Tsai
A1X1	PCN_1157	UPDATED PKG 2X3POS TO 12REELS/CARTON	06/24/2021	Roger Tsai
A1X2	PCN_1341	UPDATED PKG 2X7POS	03/17/2022	Roger Tsai
A1X3	PCN_1410	UPDATED APPEARANCE FOR PLASTIC	07/07/2022	Roy Lin

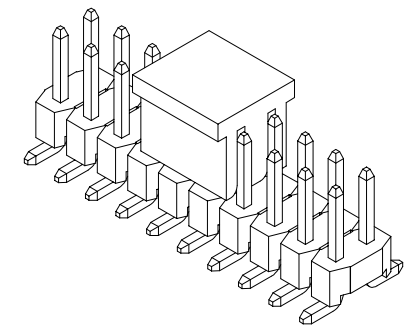
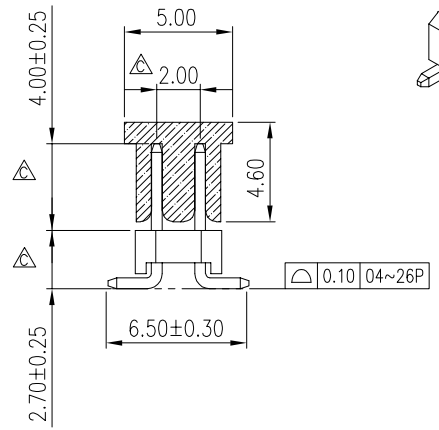
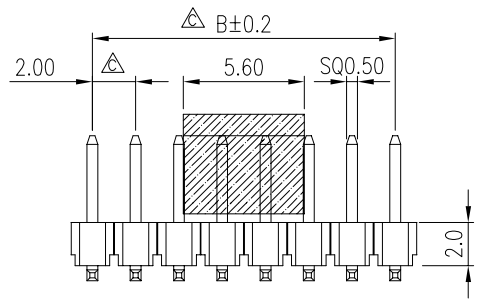
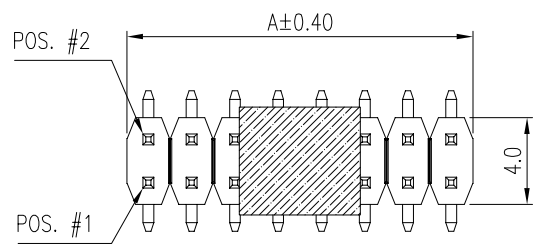

- NOTES:
- INSULATOR: LCP, UL 94V-0, COLOR- BLACK
  - PIN CONTACT: COPPER ALLOY, SELECTIVE PLATED
    - "X"- CONTACT FINISH CODE IN P/N
    - "0"- FULL 100μ" MATTE TIN
    - "1"- FLASH GOLD
    - "2"- 10μ" GOLD
    - "3"- 30μ" GOLD
    - "4"- FULL GOLD FLASH
    - "5"- 15μ" GOLD
  - SOLDER AREA: GOLD FLASH PLATED UNDER 50μ" NICKEL PLATED OVERALL
  - THIS PRODUCT IS HALOGEN-FREE PRODUCT
  - PACKING IS PER AMTA PACKING SPECIFICATION PKS-0001
  - △ ARE CRITICAL DIMENSIONS
  - PRODUCT SPECIFICATION REFER TO : PS-7510.

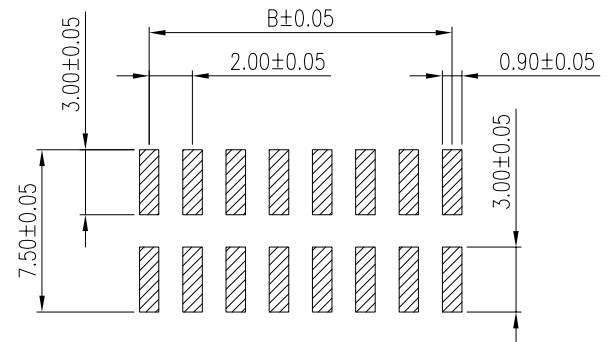

RECOMMENDED P.C.B. LAYOUT

G825M 26 X01 YEY	2 x 13 = 26	26.00	24.00
G825M 24 X01 YEY	2 x 12 = 24	24.00	22.00
G825M 22 X01 YEY	2 x 11 = 22	22.00	20.00
G825M 20 X01 YEY	2 x 10 = 20	20.00	18.00
G825M 18 X01 YEY	2 x 9 = 18	18.00	16.00
G825M 16 X01 YEY	2 x 8 = 16	16.00	14.00
G825M 14 X01 YEY	2 x 7 = 14	14.00	12.00
G825M 12 X01 YEY	2 x 6 = 12	12.00	10.00
G825M 10 X01 YEY	2 x 5 = 10	10.00	8.00
G825M 08 X01 YEY	2 x 4 = 8	8.00	6.00
G825M 06 X01 YEY	2 x 3 = 6	6.00	4.00
G825M 04 X01 YEY	2 x 2 = 4	4.00	2.00
PART NUMBER	NO. OF POS.	A	B

TOLERANCE		APPROVALS		DATE		TITLE		Amphenol®						
X. X.X ±0.30 X.XX ±0.20 X.XXX ±0.10	ANGULAR ±1°	UNLESS OTHERWISE SPECIFIED	DRAWN	Roy Lin	07/07/2022	PCB HEADER, 2.0MM PITCH DUAL ROWS, STRAIGHT SMT TYPE		Amphenol Corporation Amphenol Taiwan Corporation						
			CHECKED	Aqua Chou	07/07/2022									
			APPROVED	Roger Tsai	07/07/2022	UNIT	mm	SIZE	A3	PART No.	G825MXXX01YEU			
			DWG TYPE	CUST DWG	PROJECT CODE	HEAD	SCALE	NA	SHEET	1 OF 2	DWG No.	G825MXXX01YEU	REV.	A1X3

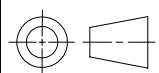

This document is the property of Amphenol Corporation and is delivered on the express condition that is not to be disclosed, reproduced or used, in whole or in part, for manufacture or sale by anyone other than Amphenol Corporation without its prior consent, and that no right is granted to disclose or to use any information in this document.

The marking on this product doesn't contain environmental hazardous materials per directive 2011/65/EU & 2015/863/EU for RoHS compliant and per IEC 61249-2-21 for Halogen-Free compliant.

**FOR REFERENCE ONLY**



REVISIONS				
SYM	ECN No.	DESCRIPTION	DATE	APPROVED
B	NE-10163	ADDED CAP	10/13/2010	Arron Lin
C	NE-11092	MODIFIED DRAWING	06/28/2011	Arron Lin
D	NE-15087	ADDED SOLDER PAD RECOMMENDED	07/28/2015	Roger Tsai
E	NE-18149	ADDED SERIES PACKAGING, REMOVED POS.40~80	07/20/2018	Roger Tsai
F	NE-19015	UPDATED COPLANARITY, REMOVED POS.28~38	09/26/2019	Roger Tsai
A1X1	PCN_1157	UPDATED PKG 2X3POS TO 12REELS/CARTON	06/24/2021	Roger Tsai
A1X2	PCN_1341	UPDATED PKG 2X7POS	03/17/2022	Roger Tsai
A1X3	PCN_1410	UPDATED APPEARANCE FOR PLASTIC	07/07/2022	Roy Lin

PARTITION BOARD 1 PCS

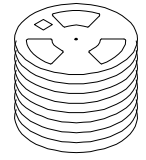
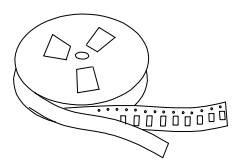
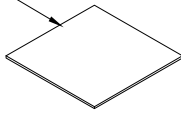

INNER BAG

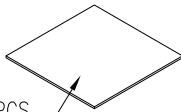
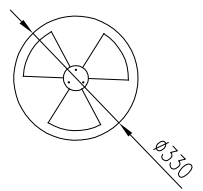
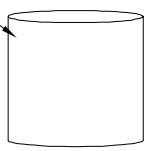

PARTITION BOARD 1 PCS

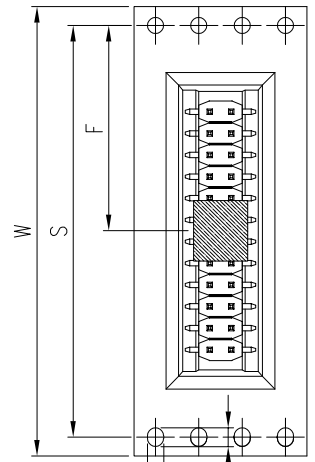

W=32~44MM

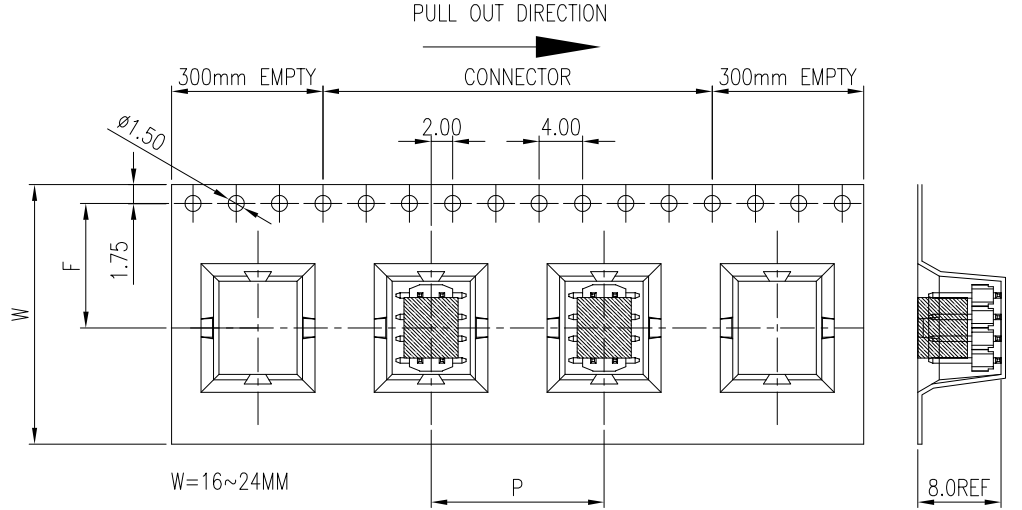

PULL OUT DIRECTION



TRIANGLE BOARD 4 PCS

SHIPPING CARTON

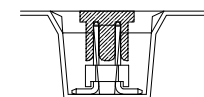
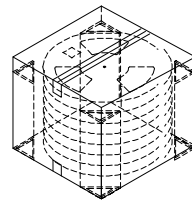
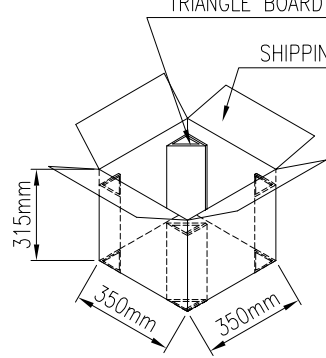

POS.	DIM W	DIM F	DIM S	DIM P	PCS/ REEL	REELS/ CARTON	QUANTITY (PCS)
2X12=24	44.0	20.2	40.4	16.0	500	5	2500
2X10=20	32.0	14.2	28.4	16.0	500	7	3500
2X09=18	32.0	14.2	28.4	12.0	500	7	3500
2X08=16	32.0	14.2	28.4	16.0	400	7	2800
2X07=14	24.0	11.5	--	16.0	400	9	3600
2X05=10	24.0	11.5	--	12.0	500	9	4500
2X04=08	24.0	11.5	--	16.0	450	9	4050
2X03=06	16.0	7.5	--	12.0	600	12	7200
2X02=04	16.0	7.5	--	12.0	600	14	8400

TOLERANCE	APPROVALS	DATE	TITLE
X. ±0.30	DRAWN Roy Lin	07/07/2022	PCB HEADER, 2.0MM PITCH DUAL ROWS, STRAIGHT SMT TYPE
X.X ±0.20			
X.XX ±0.20	CHECKED Aqua Chou	07/07/2022	
X.XXX ±0.10	APPROVED Roger Tsai	07/07/2022	
ANGULAR ±1°	DWG TYPE CUST DWG	PROJECT CODE HEAD	
UNLESS OTHERWISE SPECIFIED			

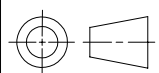

UNIT mm  
SCALE NA

SIZE A3  
SHEET 2 OF 2

PART No. G825MXXX01YEU  
DWG No. G825MXXX01YEU  
REV. A1X3

**Amphenol®**

Amphenol Corporation  
Amphenol Taiwan Corporation