

Hi-Reliability Optically Coupled Isolator



3C91C, 3C92C, 3N243, 3N244, 3N245, 3N261, 3N262, 3N263 (TX, TXV)



Features:

- TO-72 hermetically sealed package
- 1 kVDC electrical isolation
- High current transfer ratio
- TX and TXV devices processed to MIL-PRF-19500

Description:

Each device is a high reliability optically coupled isolator that consists of an infrared emitting diode and a NPN silicon phototransistor which are mounted in a hermetically sealed TO-72 package. The **3C91C** and **3C92C** have a 935 nm wavelength, whereas the **3N243**, **3N244**, **3N245**, **3N261**, **3N262** and **3N263** have an 880 nm wavelength. All devices have 0.50" (12.70 mm) leads. Electrical characteristics vary. The **3N261TX**, **3N262TX** and **3N263TX** devices are similar to JEDEC registered optically coupled isolators.

TX and TXV devices are processed to OPTEK's military screening program patterned after MIL-PRF-19500.

Please refer to Application Bulletins 208 and 210 for additional design information and reliability (degradation) data.

Contact your local representative or OPTEK for more information.

Applications:

- High-voltage isolation between input and output
- Electrical isolation in dirty environments
- Industrial equipment
- Medical equipment
- Office equipment

Part Number	LED Peak Wavelength	Sensor	Isolation Voltage (,000)	CTR Min / Max	I _F (mA) Typ / Max	V _{CE} (V) Typ / Max	Lead Length
3C91C (TX, TXV)	935 nm	Transistor	1	0.3 / 2.0	10 / 50	10 / 50	0.50"
3C92C (TX, TXV)							
3N243 (TX, TXV)	880 nm			0.15 / NA	3 / 40	10 / 30	
3N244 (TX, TXV)							
3N245 (TX, TXV)				0.6 / NA	1 / 40	5 / 30	
3N261 (TX, TXV)							
3N262 (TX, TXV)				.05 / NA			
3N263 (TX, TXV)					2.0 / 10.0		

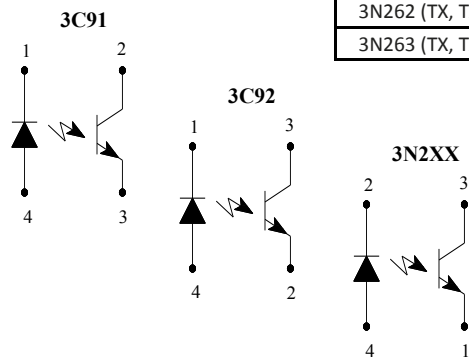

Phototransistor Collector is connected to the Header-Base-Case for ALL versions

Pin #	3C91	3C92	3N2XX
1	Cathode	Cathode	Emitter
2	Collector	Emitter	Cathode
3	Emitter	Collector	Collector
4	Anode	Anode	Anode

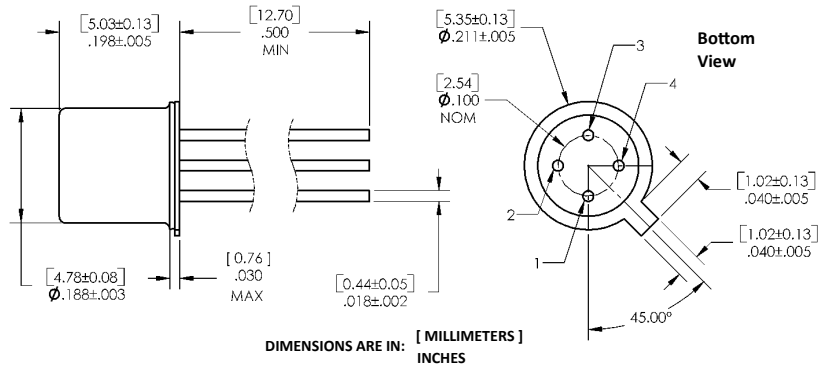

General Note

TT Electronics reserves the right to make changes in product specification without notice or liability. All information is subject to TT Electronics' own data and is considered accurate at time of going to print.

TT Electronics | Optek Technology, Inc.
1645 Wallace Drive, Ste. 130, Carrollton, TX USA 75006 | Ph: +1 972 323 2200
www.ttelectronics.com | sensors@ttelectronics.com

Hi-Reliability Optically Coupled Isolator



Absolute Maximum Ratings ($T_A = 25^\circ\text{C}$ unless otherwise noted)

Operating Temperature Range	-55° C to +125° C
Storage Temperature Range	-65° C to +150° C
Input to Output Isolation Voltage	$\pm 1\text{ kVDC}^{(1)}$
Lead Soldering Temperature [1/16 inch (1.6 mm) from case for 5 seconds with soldering iron]	260° C ⁽²⁾

Input Diode

Forward DC Current	40 mA
Reverse Voltage	2.0 V
Power Dissipation	60 mW ⁽³⁾

Output Phototransistor

Continuous Collector Current	30 mA
Collector-Emitter Voltage	30 V
Emitter-Collector Voltage	5.0 V
Power Dissipation	200 mW ⁽⁴⁾

Notes:

1. Measured with input leads shorted together and output leads shorted together.
2. RMA flux is recommended. Duration can be extended to 10 seconds maximum when flow soldering.
3. Derate linearly 2.0 mW/° C above 25° C.
4. Derate linearly 0.60 mW/° C above 65° C.

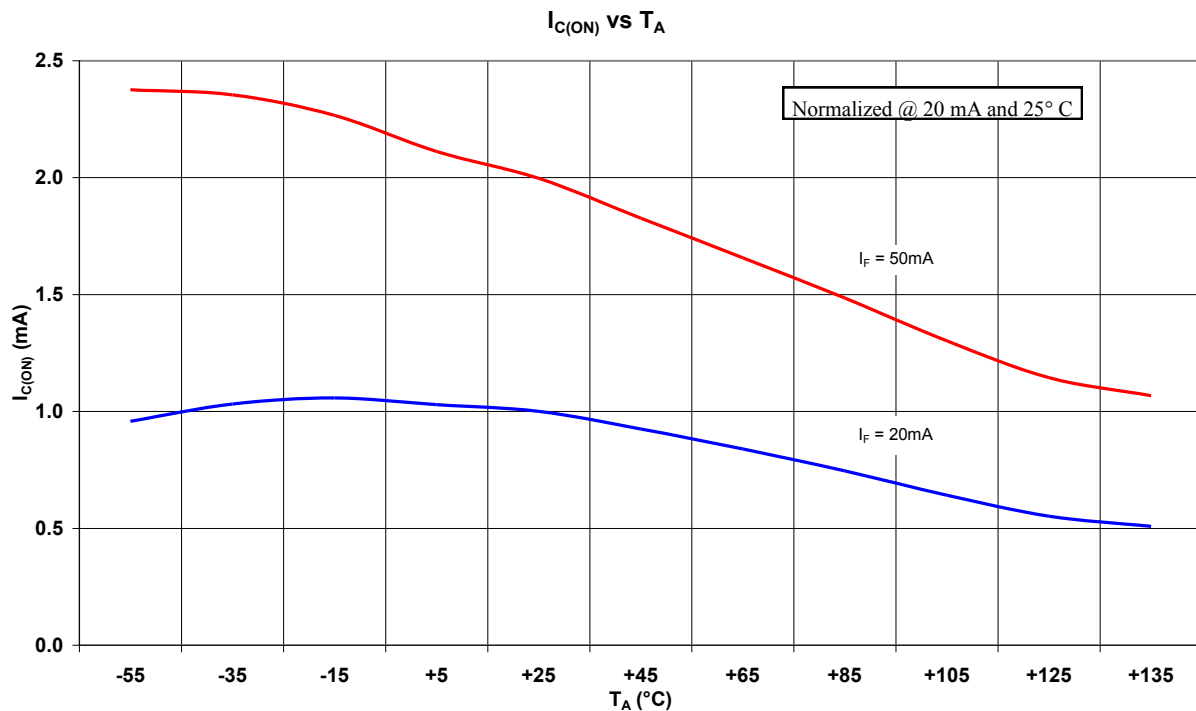

General Note

TT Electronics reserves the right to make changes in product specification without notice or liability. All information is subject to TT Electronics' own data and is considered accurate at time of going to print.

TT Electronics | Optek Technology, Inc.
1645 Wallace Drive, Ste. 130, Carrollton, TX USA 75006 | Ph: +1 972 323 2200
www.ttelectronics.com | sensors@ttelectronics.com

Hi-Reliability Optically Coupled Isolator



Electrical Characteristics (T_A = 25°C unless otherwise noted)

SYMBOL	PARAMETER	MIN	TYP	MAX	UNITS	TEST CONDITIONS
Input Diode						
V _F	Forward Voltage 3C91C, 3C92C (TX, TXV)	-	-	1.2	V	I _F = 2 mA
	3C91C, 3C92C (TX, TXV)	-	-	1.5		I _F = 50 mA
	3N243, 3N244, 3N245 (TX, TXV)	0.8	-	1.3		I _F = 10 mA
	3N243, 3N244, 3N245 (TX, TXV)	1.0	-	1.5		I _F = 10 mA, T _A = -55° C
	3N243, 3N244, 3N245 (TX, TXV)	0.7	-	1.2		I _F = 10 mA, T _A = -100° C
	3N261, 3N262, 3N263 (TX, TXV)	0.8	-	1.5		I _F = 10 mA
	3N261, 3N262, 3N263 (TX, TXV)	1.0	-	1.7		I _F = 10 mA, T _A = -55° C
3N261, 3N262, 3N263 (TX, TXV)	0.7	-	1.3	I _F = 10 mA, T _A = -100° C		
V _R	Reverse Voltage 3C91C, 3C92C (TX, TXV)	7	-	-	V	I _R = 0.1 mA
I _R	Reverse Current 3C91C, 3C92C (TX, TXV)	-	-	1	μA	V _R = 3.0 V
	3N243, 3N244, 3N245 (TX, TXV)	-	-	100		V _R = 2.0 V
	3N261, 3N262, 3N263 (TX, TXV)	-	-	100		V _R = 2.0 V
C _{IN}	Diode Capacitance 3C91C, 3C92C (TX, TXV)	-	25	-	pF	V = 0, f = 1 MHz

Output Phototransistor

V _{(BR)CEO}	Collector-Emitter Breakdown Voltage 3C91C, 3C92C (TX, TXV)	50	-	-	V	I _C = 10.0 mA
	3N243, 3N244, 3N245 (TX, TXV)	30	-	-		I _C = 1.0 mA
	3N261, 3N262, 3N263 (TX, TXV)	40	-	-		I _C = 1.0 mA
V _{(BR)ECO}	Emitter-Collector Breakdown Voltage 3C91C, 3C92C (TX, TXV)	7	-	-	V	I _C = 10 μA
	3N243, 3N244, 3N245 (TX, TXV)	5	-	-		I _E = 100 μA
	3N261, 3N262, 3N263 (TX, TXV)	7	-	-		I _E = 100 μA
I _{CEO}	Collector Dark Current 3C91C, 3C92C (TX, TXV)	-	-	10	nA	V _{CE} = 5 V
	3C91C, 3C92C (TX, TXV)	-	-	50	nA	V _{CE} = 50 V
	3N243, 3N244, 3N245 (TX, TXV)	-	-	100	nA	V _{CE} = 10.0 V
	3N243, 3N244, 3N245 (TX, TXV)	-	-	100	μA	V _{CE} = 10.0 V, T _A = 100° C
	3N261, 3N262, 3N263 (TX, TXV)	-	-	100	μA	V _{CE} = 10.0 V
	3N261, 3N262, 3N263 (TX, TXV)	-	-	100	μA	V _{CE} = 10.0 V, T _A = 100° C

General Note

TT Electronics reserves the right to make changes in product specification without notice or liability. All information is subject to TT Electronics' own data and is considered accurate at time of going to print.

TT Electronics | Optek Technology, Inc.
1645 Wallace Drive, Ste. 130, Carrollton, TX USA 75006 | Ph: +1 972 323 2200
www.ttelectronics.com | sensors@ttelectronics.com

Hi-Reliability Optically Coupled Isolator



Electrical Characteristics (T_A = 25°C unless otherwise noted)

SYMBOL	PARAMETER	MIN	TYP	MAX	UNITS	TEST CONDITIONS
Coupled						
I _{C(ON)}	On-State Collector Current					
	3C91C, 3C92C (TX, TXV)	4.0	-	-		I _F = 10 mA, V _{CE} = 5 V
	3C91C, 3C92C (TX, TXV)	3.0	-	20		I _F = 10 mA, V _{CE} = 0.4 V
	3N243 (TX, TXV)	1.5	-	-		I _F = 10 mA, V _{CE} = 10.0 V
	3N243 (TX, TXV)	0.3	-	-		I _F = 3 mA, V _{CE} = 10.0 V
	3N243 (TX, TXV)	0.5	-	-		I _F = 10 mA, V _{CE} = 10.0 V, T _A = 55° C
	3N243 (TX, TXV)	0.5	-	-		I _F = 10 mA, V _{CE} = 10.0 V, T _A = 100° C
	3N244 (TX, TXV)	3.0	-	-		I _F = 10 mA, V _{CE} = 10.0 V
	3N244 (TX, TXV)	0.8	-	-		I _F = 3 mA, V _{CE} = 10.0 V
	3N244 (TX, TXV)	1.0	-	-		I _F = 10 mA, V _{CE} = 10.0 V, T _A = 55° C
	3N244(TX, TXV)	1.0	-	-		I _F = 10 mA, V _{CE} = 10.0 V, T _A = 100° C
	3N245 (TX, TXV)	6.0	-	-		I _F = 10 mA, V _{CE} = 10.0 V
	3N245 (TX, TXV)	1.5	-	-		I _F = 3 mA, V _{CE} = 10.0 V
	3N245(TX, TXV)	1.5	-	-		I _F = 10 mA, V _{CE} = 10.0 V, T _A = 55° C
	3N245(TX, TXV)	1.5	-	-		I _F = 10 mA, V _{CE} = 10.0 V, T _A = 100°
	3N261(TX, TXV)	0.5	-	-		I _F = 1 mA, V _{CE} = 5.0 V
	3N261 (TX, TXV)	0.7	-	-		I _F = 2.0 mA, V _{CE} = 5.0 V, T _A = 55° C
	3N261 (TX, TXV)	0.5	-	-		I _F = 2.0 mA, V _{CE} = 5.0 V, T _A = 100° C
	3N262 (TX, TXV)	1.0	-	5		I _F = 1 mA, V _{CE} = 5.0 V
	3N262(TX, TXV)	1.4	-	-		I _F = 2.0 mA, V _{CE} = 5.0 V, T _A = 55° C
3N262 (TX, TXV)	1.0	-	-		I _F = 2.0 mA, V _{CE} = 5.0 V, T _A = 100° C	
3N263 (TX, TXV)	2.0	-	10		I _F = 1 mA, V _{CE} = 5.0 V	
3N263(TX, TXV)	2.8	-	-		I _F = 2.0 mA, V _{CE} = 5.0 V, T _A = 55° C	
3N263(TX, TXV)	2.0	-	-		I _F = 2.0 mA, V _{CE} = 5.0 V, T _A = 100° C	
V _{CE(SAT)}	Collector-Emitter Saturation Voltage					
	3C91C, 3C92C (TX, TXV)	-	-	0.4		I _F = 50 mA, I _C = 10 mA
	3N243, 3N244, 3N245 (TX, TXV)	-	-	0.3		I _F = 20 mA, I _C = 1.50 mA
	3N243, 3N244, 3N245 (TX, TXV)	-	-	0.3		I _F = 20 mA, I _C = 3.0 mA
	3N243, 3N244, 3N245 (TX, TXV) 3N261,	-	-	0.3		I _F = 20 mA, I _C = 6.0 mA
	3N262, 3N263 (TX, TXV)	-	-	0.3		I _F = 2.0 mA, I _C = 0.50 mA
	3N261, 3N262, 3N263 (TX, TXV)	-	-	0.3		I _F = 2.0 mA, I _C = 1.0 mA
3N261, 3N262, 3N263 (TX, TXV)	-	-	0.3		I _F = 2.0 mA, I _C = 2.0 mA	
t _{ON}	Turn-on Time 3C91C, 3C92C (TX, TXV)	-	-	9	μs	V _{CC} = 5 V, I _C = 2 mA, R _L = 100 Ω
t _{IOFF}	Turn-off Time 3C91C, 3C92C (TX, TXV))	-	-	6	μs	V _{CC} = 5 V, I _C = 2 mA, R _L = 100 Ω

General Note

TT Electronics reserves the right to make changes in product specification without notice or liability. All information is subject to TT Electronics' own data and is considered accurate at time of going to print.

TT Electronics | Optek Technology, Inc.
1645 Wallace Drive, Ste. 130, Carrollton, TX USA 75006 | Ph: +1 972 323 2200
www.ttelectronics.com | sensors@ttelectronics.com

Hi-Reliability Optically Coupled Isolator



Electrical Characteristics (T_A = 25°C unless otherwise noted)

SYMBOL	PARAMETER	MIN	TYP	MAX	UNITS	TEST CONDITIONS
Coupled						
C _{IO}	Input-to-Output Capacitance 3C91C, 3C92C (TX, TXV) 3N243, 3N244, 3N245 (TX, TXV) 3N261, 3N262, 3N263 (TX, TXV)	-	2	2.5 5.0 5.0	pF	f = 1 MHz V _{IO} = 0 V, f = 1.00 MHz ⁽¹⁾ V _{IO} = 0 V, f = 1.00 MHz ⁽¹⁾
I _{IO}	Leakage Input -to-Output 3N243, 3N244, 3N245 (TX, TXV) 3N261, 3N262, 3N263 (TX, TXV)	-	-	100 10	nA	V _{IO} = ± 1.00 kVDC ⁽¹⁾ V _{IO} = ± 1.00 kVDC ⁽¹⁾
R _{IO}	Isolation Resistance 3C91C, 3C92C (TX, TXV)	10 ⁹	-	-	Ω	V _{IO} = +1 kV
t _r	Output Rise Time 3N243, 3N244, 3N245 (TX, TXV) 3N261, 3N262 (TX, TXV) 3N263 (TX, TXV)	-	-	10 20 25	μs	V _{CC} = 10.0 V, I _F = 10.0 mA, R _L = 100 Ω ⁽²⁾ V _{CC} = 10.0 V, I _F = 5.0 mA, R _L = 100 Ω ⁽²⁾ V _{CC} = 10.0 V, I _F = 5.0 mA, R _L = 100 Ω ⁽²⁾
t _f	Output Fall Time 3N243, 3N244, 3N245 (TX, TXV) 3N261, 3N262 (TX, TXV) 3N263 (TX, TXV)	-	-	10 10 25	μs	V _{CC} = 10.0 V, I _F = 10.0 mA, R _L = 100 Ω ⁽²⁾ V _{CC} = 10.0 V, I _F = 5.0 mA, R _L = 100 Ω ⁽²⁾ V _{CC} = 10.0 V, I _F = 5.0 mA, R _L = 100 Ω ⁽²⁾

Notes:

- Measured with input leads shorted together and output leads shorted together.
- The input waveform is supplied by a generator with the following characteristics: Z_{OUT} = 50 Ω, t_r ≤ 15 ns, duty cycle ~ 1%, pulse width ~ 100 ms

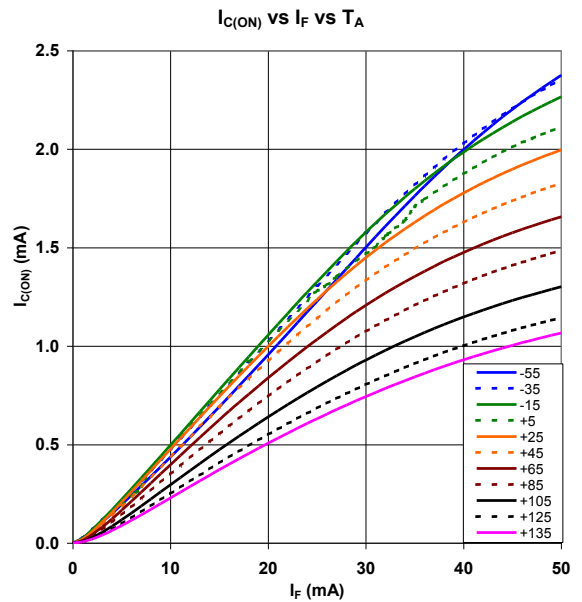
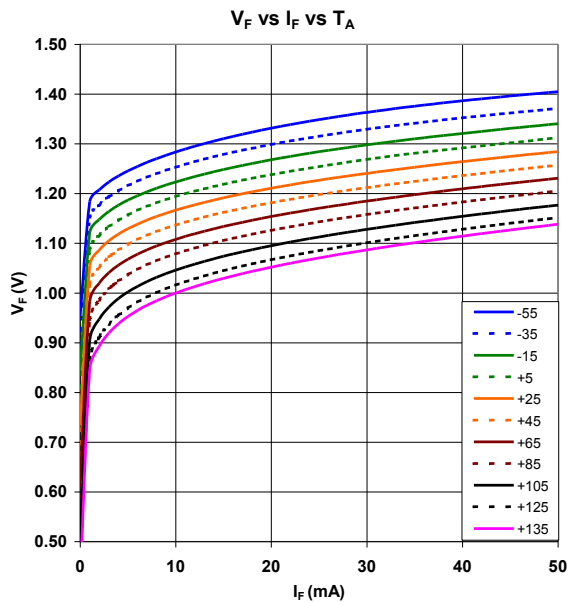

General Note

TT Electronics reserves the right to make changes in product specification without notice or liability. All information is subject to TT Electronics' own data and is considered accurate at time of going to print.

TT Electronics | Optek Technology, Inc.
1645 Wallace Drive, Ste. 130, Carrollton, TX USA 75006 | Ph: +1 972 323 2200
www.ttelectronics.com | sensors@ttelectronics.com