

THIS DRAWING IS UNPUBLISHED. RELEASED FOR PUBLICATION  
 © COPYRIGHT - By - ALL RIGHTS RESERVED.

LOC	DIST	REVISIONS			DAP		
G	14	P	LTR	DESCRIPTION	DATE	OWN	APVD
		E2		REVISED PER ECO-11-004820	11MAR11	RK	HMR

<b>AMP</b> WIRE RANGE	Listed FILE E13288	LR7189 Certified
12-10 AWG SOLID OR STRANDED	12-10 AWG STRANDED	12-10 AWG SOLID OR STRANDED

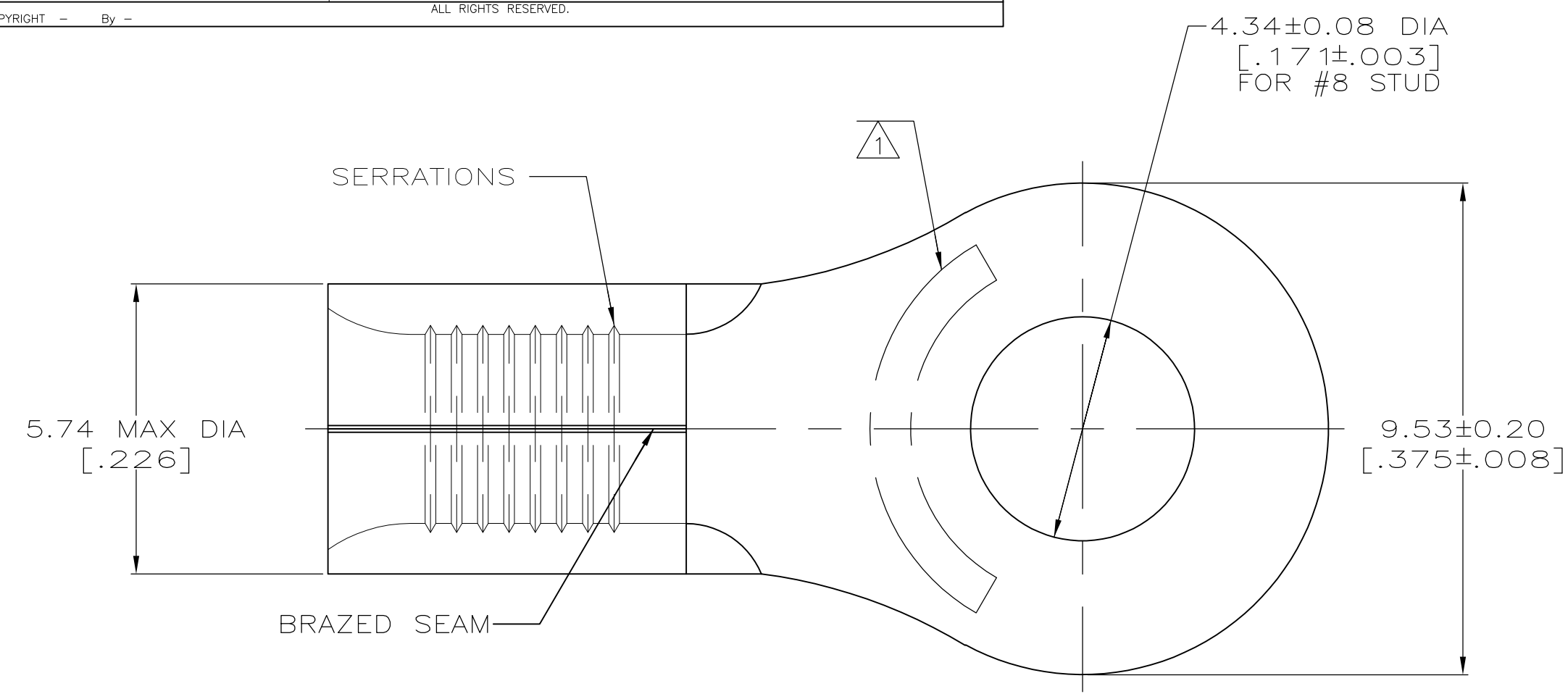

- ① STAMP AMP 12-10\* APPROX AS SHOWN
- ② COPPER PER ASTM B-152, ANNEALED
- ③ TIN PLATE 0.00254 [.000100] MIN THK PER ASTM B545
- ④ TIN/LEAD (93-7) PLATE PER ASTM B545 ( 3% MIN LEAD CONTENT ).

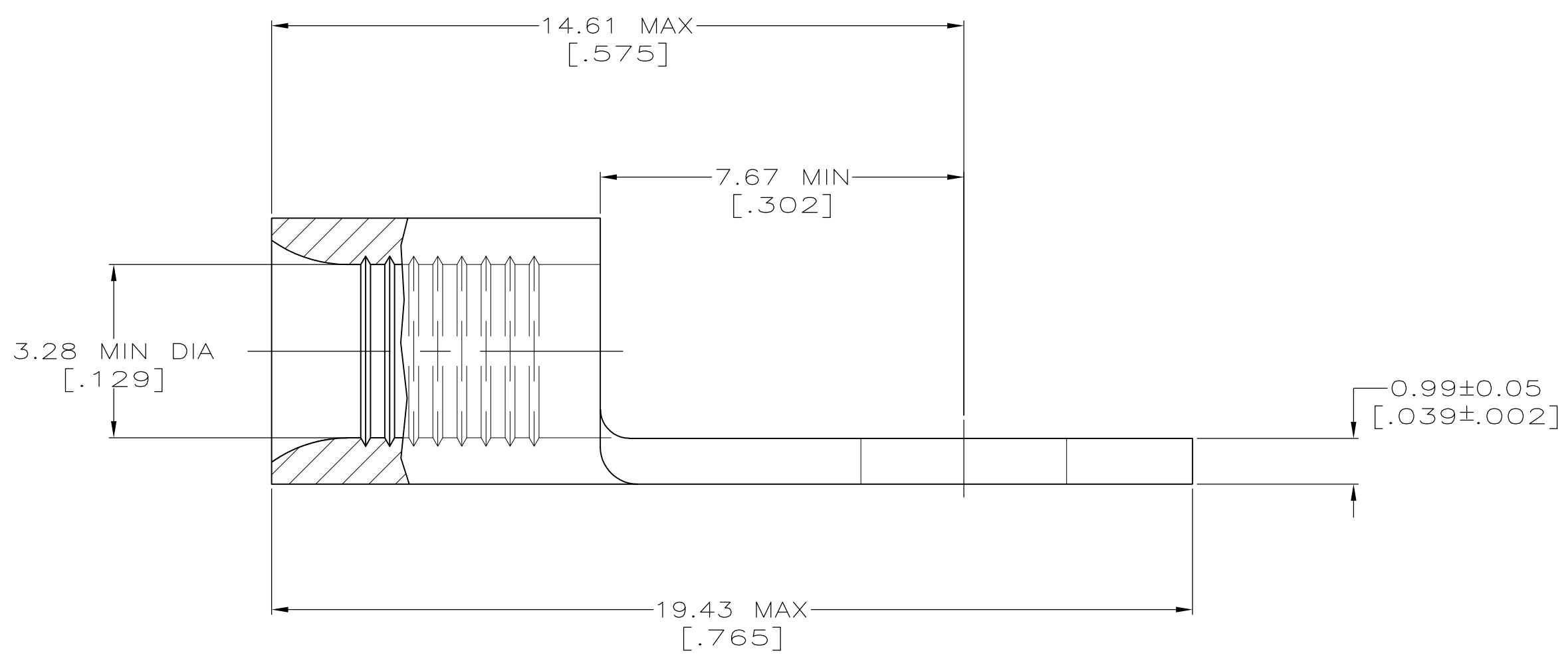

25	③	LOOSE PIECE, BAG	8-32994-5
50	③	LOOSE PIECE, BOX	8-32994-2
2500	③	ON TAPE	2-32994-1
500	④	LOOSE PIECE	32994-1
500	③	LOOSE PIECE	32994
QUANTITY	FINISH	PACKAGING TYPE	PART NO.

<b>AMP INCORPORATED</b>		MAX RECOMMENDED OPERATING TEMPERATURE: 170°C
<b>CUSTOMER SERVICE SYSTEMS</b>		
FOR ADDITIONAL PRODUCT INFORMATION OR COPIES OF DRAWINGS AND TECHNICAL DOCUMENTS	PRODUCT INFORMATION CENTER 1-800-522-6752	VOLTAGE RATING: N/A
FOR APPLICATION TOOLING INFORMATION	TOOLING ASSISTANCE CENTER 1-800-722-1111	CIRCULAR MIL AREA: 2.62-6.64mm² [5,180-13,100] SOLID OR STRANDED
FOR ORDER ENTRY	1-800-526-5142	

THIS DRAWING IS A CONTROLLED DOCUMENT.		DWN TA BRINKMAN 3-17-93	TE Connectivity	
DIMENSIONS: MM [INCHES]		CHK DA PATTERSON 3-17-93		
TOLERANCES UNLESS OTHERWISE SPECIFIED:		APVD JL MECKLEY 3-17-93	NAME TERMINAL, RING TONGUE, SOLISTRAND	
0 PLC ± -		PRODUCT SPEC	SIZE A2	
1 PLC ± -		APPLICATION SPEC	CAGE CODE 00779	
2 PLC ± -		FINISH	DRAWING NO G-32994	
3 PLC ± -		SEE NOTES	RESTRICTED TO	
4 PLC ± -			WEIGHT -	
ANGLES ± ± -			SCALE 10:1	
MATERIAL ②			SHEET 1 of 1	
			REV E2	
			CUSTOMER DRAWING	