



FocusLCDs.com
LCDs MADE SIMPLE®

Ph. 480-503-4295 | NOPP@FocusLCD.com

TFT | CHARACTER | UWVD | FSC | SEGMENT | CUSTOM | REPLACEMENT

TFT Display Module

Part Number

E40RD-FS1000-N

Overview:

- 3.95-inch TFT: (77x80mm)
- 480(RGB)x480 pixels
- LVDS Interface
- Special Temperature Range
- All View
- Transmissive
- No Touch Panel
- 1000 NITS
- Controller: ST7701S
- RoHS Compliant

Description

This is a color active matrix TFT (Thin Film Transistor) LCD (Liquid Crystal Display) that uses amorphous silicon TFT as a switching device. This model is composed of a transmissive type TFT-LCD Panel, driver circuit and a backlight unit. The resolution of the 3.95" TFT-LCD contains 480x480 pixels and can display up to 16.7M colors.

TFT Features

Display Colors: 16.7M

TFT Interfaces: 4-Lane LVDS

Controller IC: ST7701S

General Information Items	Specification	Unit	Note
	Main Panel		
TFT Display area (AA)	71.86 (H) x 70.18 (V) (3.95 inch)	mm	-
Driver element	TFT active matrix	-	-
Display colors	16.7M	colors	-
Number of pixels	480(RGB)x480	dots	-
TFT Pixel arrangement	RGB vertical stripe	-	-
Pixel pitch	0.1497 (H) x 0.1462 (V)	mm	-
Viewing angle	ALL	o'clock	-
TFT Controller IC	ST7701S	-	-
LCM Interface	4-Lane LVDS	-	-
Display mode	Transmissive/ Normally Black	-	-
Operating temperature	-20~+60	°C	-
Storage temperature	-30~+75	°C	-

Mechanical Information

Item		Min	Typ.	Max	Unit	Note
Module size	Height (H)		77		mm	-
	Vertical (V)		80		mm	-
	Depth (D)		2.35		mm	-
Weight			25		g	-

1. Block Diagram

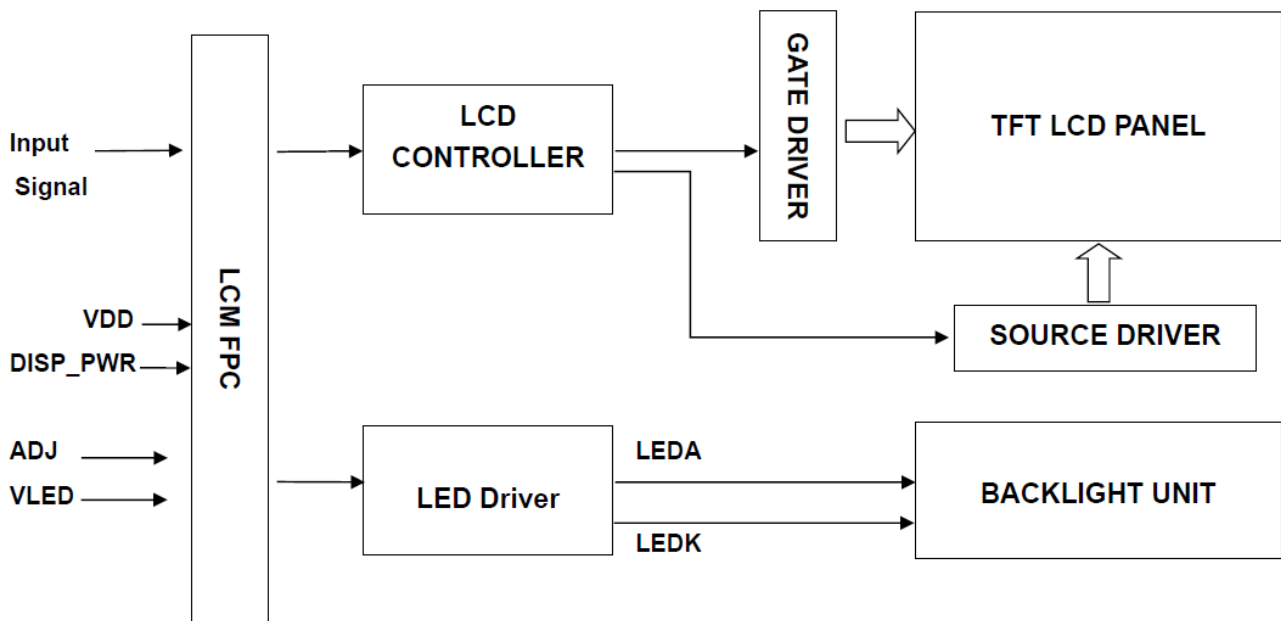

2. Outline Dimensions

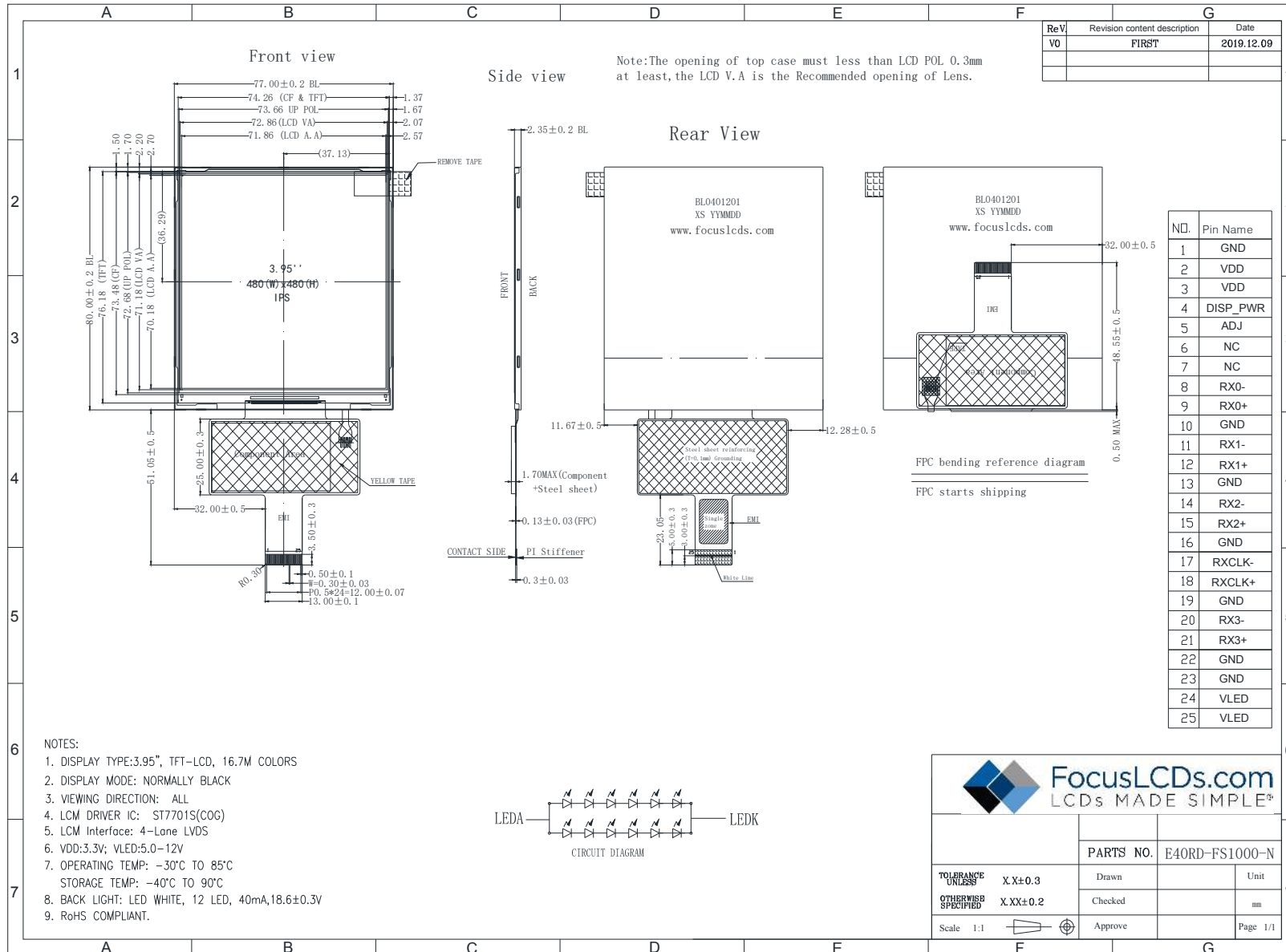

3. Input Terminal Pin Assignment

Recommended Connector: FH52-25S-0.5SH(99)

NO.	Symbol	Description	I/O
1	GND	Ground	P
2	VDD	Supply Voltage (3.3V)	P
3	VDD	Supply Voltage (3.3V)	P
4	DSIP_PWR	Display power control pin. H: Power on, L: Power off. Internal pull down resistor 100k.	P
5	ADJ	B/L enable and dimming input pin. ADJ=1: B/L On, ADJ=0: B/L Off. PWM and digital dimming input. Internal pull down resistor 100k.	P
6	NC	--	--
7	NC	--	--
8	RX0-	-LVDS differential data input	I
9	RX0+	+LVDS differential data input	I
10	GND	Ground	P
11	RX1-	-LVDS differential data input	I
12	RX1+	+LVDS differential data input	I
13	GND	Ground	P
14	RX2-	-LVDS differential data input	I
15	RX2+	+LVDS differential data input	I
16	GND	Ground	P
17	RXCLK-	-LVDS differential clock input	I
18	RXCLK+	+LVDS differential clock input	I
19	GND	Ground	P
20	RX3-	-LVDS differential data input	I
21	RX3+	+LVDS differential data input	I
22	GND	Ground	P
23	GND	Ground	P
24	VLED	LED driver supply voltage	P
25	VLED	LED driver supply voltage	P

4. LCD Optical Characteristics

4.1 Optical Specifications

Item	Symbol	Condition	Min	Typ.	Max	Unit	Note	
Contrast Ratio	CR	$\theta=0$ Normal viewing angle	800	1000	--	%	(2)	
Response Time	Rising		Tr+Tf	--	25	35	ms	
	Falling							
Color Gamut	S(%)		49	54	--	%	(5)	
Color Filter Chromaticity	White		W _x	0.253	0.293	0.333		(5)(6)
			W _y	0.284	0.324	0.364		
	Red		R _x	0.571	0.611	0.651		
			R _y	0.324	0.364	0.404		
	Green		G _x	0.271	0.311	0.351		
			G _y	0.515	0.555	0.595		
	Blue	B _x	0.106	0.146	0.186			
		B _y	0.051	0.091	0.131			
Viewing Angle	Hor.	ΘL	70	80	--	degree	(1)(6)	
		ΘR	70	80	--			
	Ver.	ΘT	70	80	--			
		ΘB	70	80	--			
Option View Direction		CR≥10					(1)	
			ALL				(1)	

Optical Specification Reference Notes:

(1) Definition of Viewing Angle: The viewing angle is the angle at which the contrast ratio is greater than 10. The viewing angles are determined for the horizontal or 3,9 o'clock direction and the vertical or 6,12 o'clock direction with respect to the optical axis which is normal to the LCD surface.

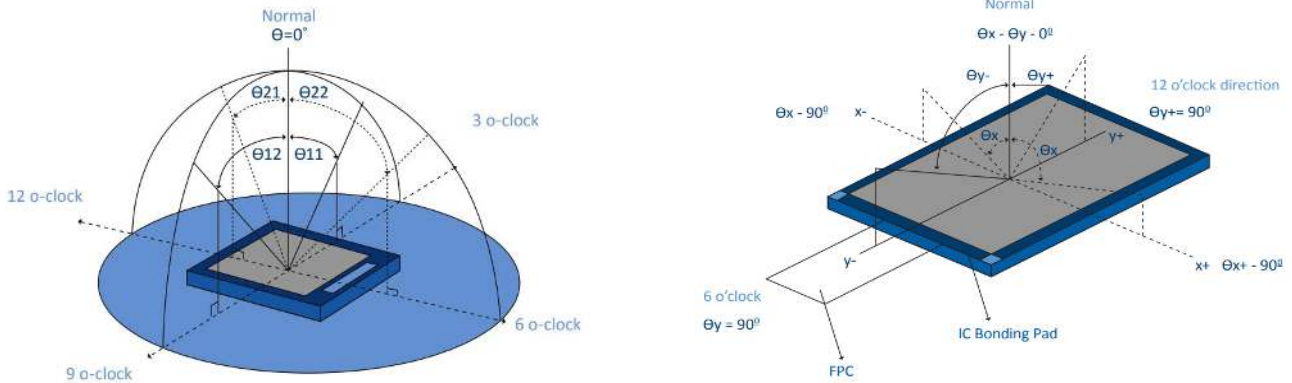

(2) Definition of Contrast Ratio (Cr): measured at the center point of panel. The contrast ratio (Cr) measured on a module, is the ratio between the luminance (Lw) in a full white area (R=G=B=1) and the luminance (Ld) in a dark area (R=G=B=0).

$$Cr = \frac{Lw}{Ld}$$

(3) Definition of transmittance (T%): The transmittance of the panel including the polarizers is measured with electrical driving. The equation for transmittance Tr is:

$$Tr = \frac{It}{Io} \times 100\%$$

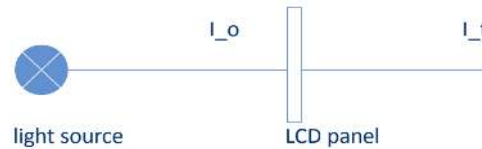

Io = the brightness of the light source.
 It = the brightness after panel transmission

(4) Definition of Response Time (Tr, Tf): The rise time 'Tr' is defined as the time for luminance to change from 90% to 10% as a result of a change of the electrical condition. The fall time 'Tf' is defined as the time for luminance to change from 10% to 90% as a result of a change of the electrical condition.

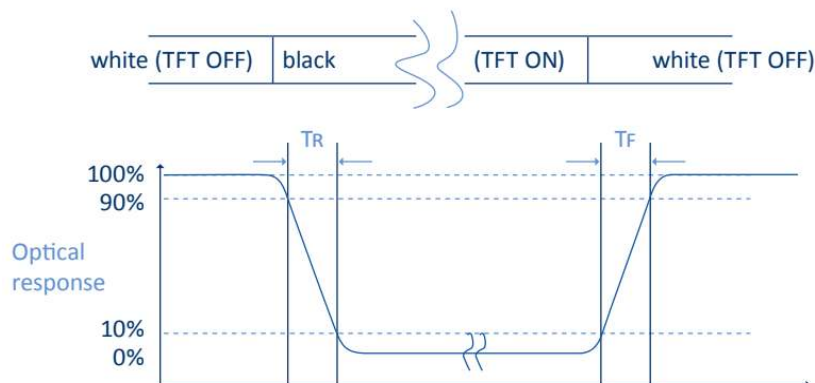

(5) Definition of Color Gamut:

Measuring machine CFT-01. NTSC's Primaries: $R(x,y,Y), G(x,y,Y), B(x,y,Y)$. FPM520 of Westar Display Technologies, INC., which utilized SR-3 for Chromaticity and BM-5A for other optical characteristics. The color chromaticity shall be calculated from the spectral data measured with all pixels first in red, green, blue and white. Measurements shall be made at the center of the panel.

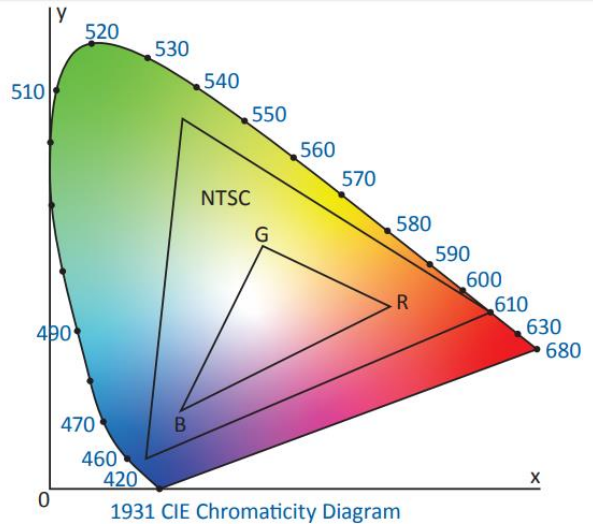
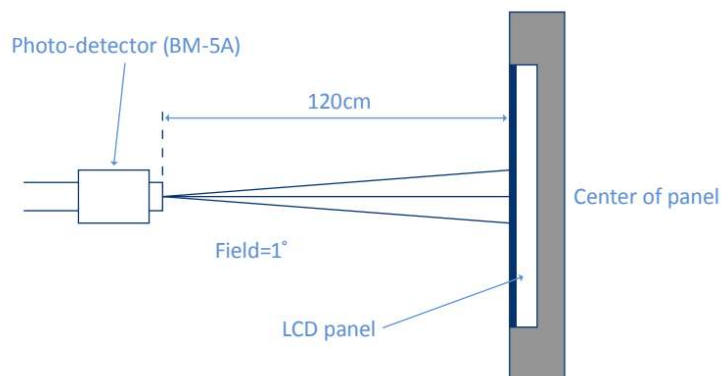
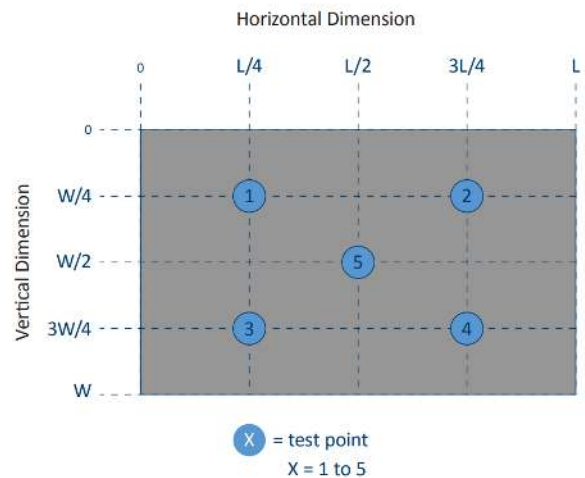
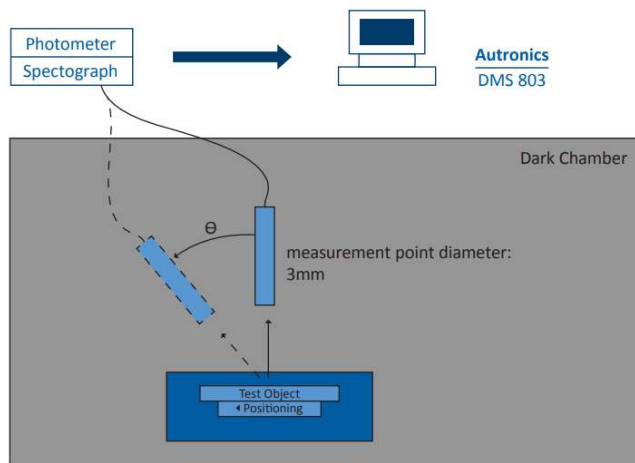

Fig. 1931 CIE chromacity diagram

$$\text{Color gamut: } S = \frac{\text{Area of RGB triangle}}{\text{Area of NTSC triangle}} \times 100\%$$

(6) Definition of Optical Measurement Setup:

The LCD module should be stabilized at a given temperature for 20 minutes to avoid abrupt temperature change during measuring. In order to stabilize the luminance, the measurement should be executed after lighting backlight for 20 minutes.



5. TFT Electrical Characteristics

5.1 Absolute Maximum Rating (Ta=25 °C, VSS=0V)

Characteristics	Symbol	Min	Max	Unit
LCM Supply Voltage	VDD	-0.3	4.6	V
BL Supply Voltage	VLED	-0.3	20	V
CMOS/TTL Input Voltage	--	-0.3	VDD+0.3	V
CMOS/TTL Output Voltage	--	-0.3	VDD+0.3	V
LVDS Input Pin	--	-0.3	VDD+0.3	V
Operating Temperature	TOP	-30	+85	°C
Storage Temperature	TST	-40	+90	°C

NOTE: If the absolute maximum rating of the above parameters is exceeded, even momentarily, the quality of the product may be degraded. Absolute maximum ratings specify the values which the product may be physically damaged if exceeded. Be sure to use the product within the range of the absolute maximum ratings.

5.2 DC Electrical Characteristics

Characteristics	Symbol	Min	Typ.	Max	Unit	Note
LCM Supply Voltage	VDD	2.5	3.3	3.6	V	
LCM Normal Mode Current	IDD	--	68	136	mA	
Differential Input High Threshold Voltage	VLVTH	--	--	100	mV	
Differential Input Low Threshold Voltage	VLVTL	-100	--	--	mV	
Level Input Voltage	VIL	GND	--	0.3*VDD	V	
Level Output Voltage	VIH	0.7*VDD	--	VDD	V	

5.3 LED Backlight Driving Conditions

Characteristics	Symbol	Min	Typ.	Max	Unit	Note
VLED Supply Voltage	VLED	4.5	5.0	12	V	
VLED Current Consumption	IDD	--	170	--	mA	
LED_EN Logic High Voltage	VIH	1.2	--	--	V	
LED_EN Logic Low Voltage	VIL	--	--	0.4	V	
PWM Control Frequency	FDIM	5	--	100	kHz	

6.2 Timing Tables

The display operation via the RGB interface is synchronized with the VSYNC, HSYNC and DOTCLK signals. The data can be written only within the specified area with low power consumption by using the window address function. The back porch and front porch are used to set the RGB interface timing signals.

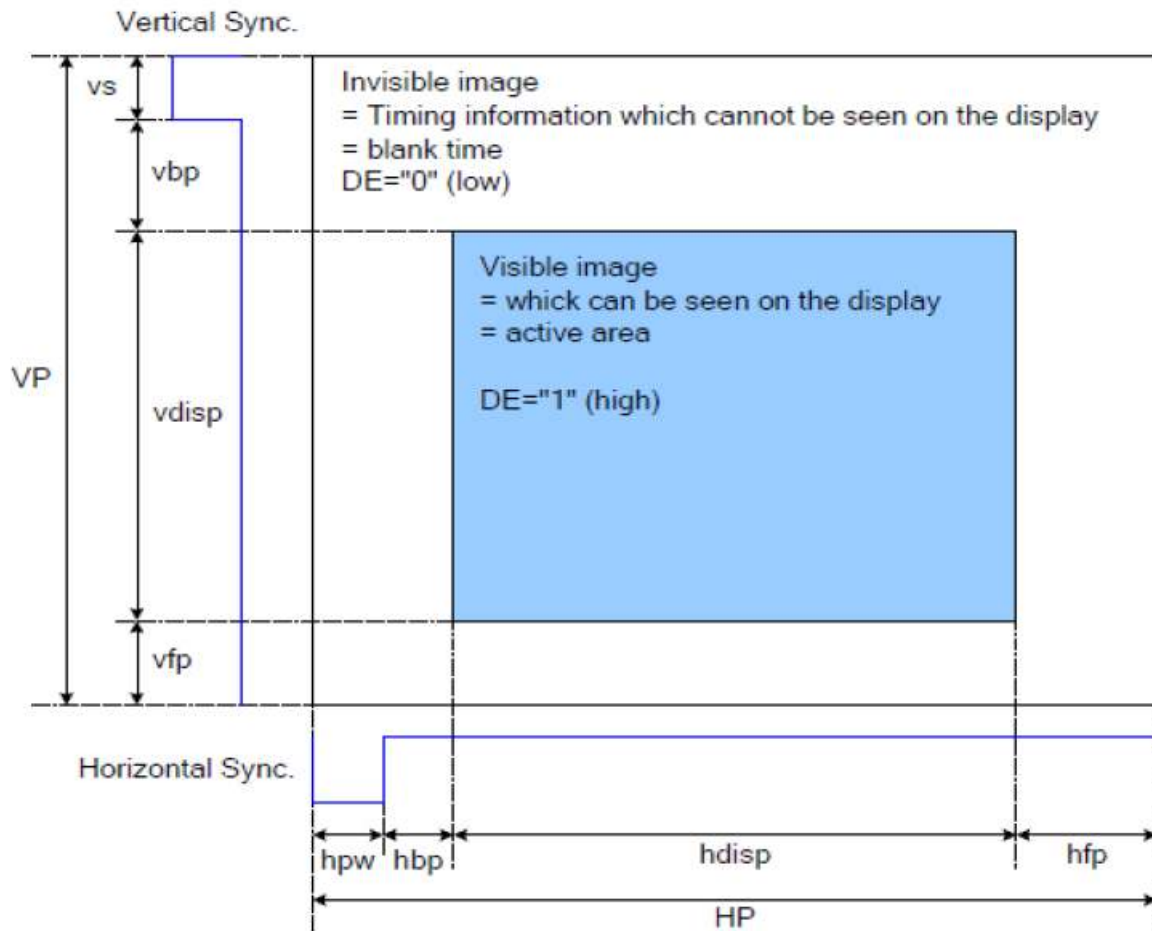

Parameter	Symbol	Condition	Min	Typ	Max	Unit
DCLK frequency	fclk		--	17	--	MHz
Horizontal sync width	hpw		1	8	255	Clock
Horizontal back porch	hbp		1	50	255	Clock
Horizontal front porch	hfp		1	10	--	Clock
Vertical sync width	vs		1	8	254	Line
Vertical back porch	vbp		1	20	254	Line
Vertical front porch	vfp		1	21	--	Line

6.3 LVDS Data Input Format

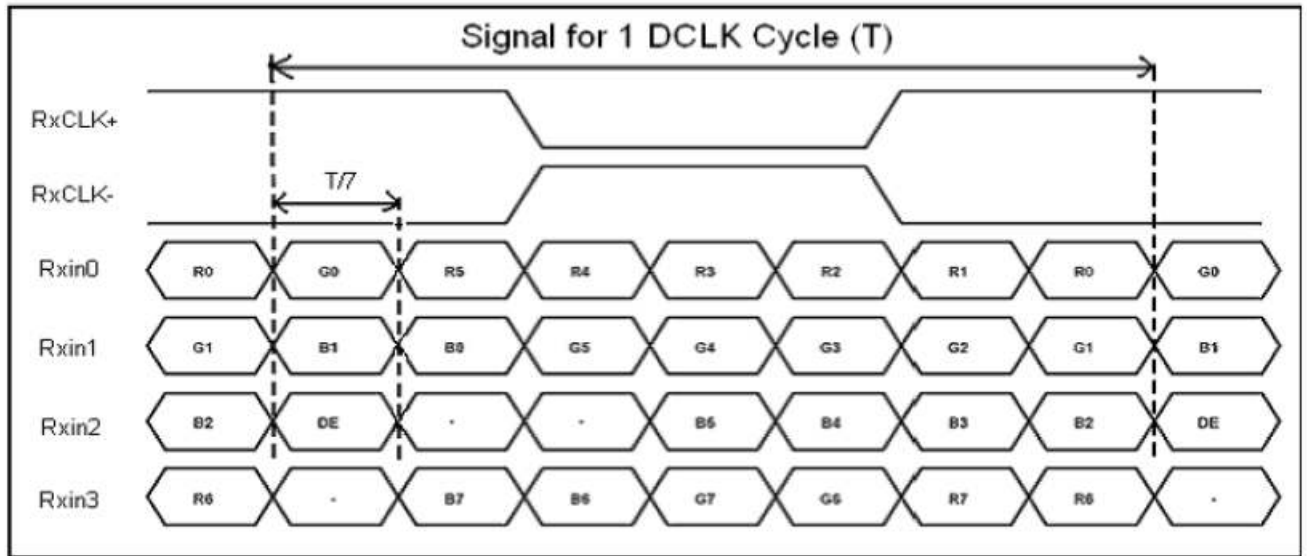

7. Cautions and Handling Precautions

7.1 Handling and Operating the Module

1. When the module is assembled, it should be attached to the system firmly. Do not warp or twist the module during assembly work.
2. Protect the module from physical shock or any force. In addition to damage, this may cause improper operation or damage to the module and back-light unit.
3. Note that polarizer is very fragile and could be easily damaged. Do not press or scratch the surface.
4. Do not allow drops of water or chemicals to remain on the display surface. If you have the droplets for a long time, staining and discoloration may occur.
5. If the surface of the polarizer is dirty, clean it using some absorbent cotton or soft cloth.
6. The desirable cleaners are water, IPA (Isopropyl Alcohol) or Hexane. Do not use ketene type materials (ex. Acetone), Ethyl alcohol, Toluene, Ethyl acid or Methyl chloride. It might permanent damage to the polarizer due to chemical reaction.
7. If the liquid crystal material leaks from the panel, it should be kept away from the eyes or mouth. In case of contact with hands, legs, or clothes, it must be washed away thoroughly with soap.
8. Protect the module from static; it may cause damage to the CMOS ICs.
9. Use fingerstalls with soft gloves in order to keep display clean during the incoming inspection and assembly process.
10. Do not disassemble the module.
11. Protection film for polarizer on the module shall be slowly peeled off just before use so that the electrostatic charge can be minimized.
12. Pins of I/F connector shall not be touched directly with bare hands.
13. Do not connect, disconnect the module in the "Power ON" condition.
14. Power supply should always be turned on/off by the item Power On Sequence & Power Off Sequence

7.2 Storage and Transportation

1. Do not leave the panel in high temperature, and high humidity for a long time. It is highly recommended to store the module with temperature from 0 to 35 °C and relative humidity of less than 70%
2. Do not store the TFT-LCD module in direct sunlight.
3. The module shall be stored in a dark place. When storing the modules for a long time, be sure to adopt effective measures for protecting the modules from strong ultraviolet radiation, sunlight, or fluorescent light.
4. It is recommended that the modules should be stored under a condition where no condensation is allowed. Formation of dewdrops may cause an abnormal operation or a failure of the module. In particular, the greatest possible care should be taken to prevent any module from being operated where condensation has occurred inside.
5. This panel has its circuitry FPC on the bottom side and should be handled carefully in order not to be stressed.