

REV.	DESCRIPTION	DATE	APPROVED
B	Engineering Update w/o Changes	02/27/04	M. C.
C	Core Modification	02/26/08	M. C.
D	Corrected Conversion Error	03/03/08	M. C.
E	Removed Core Modification	08/05/09	T. Y.
F	Removed Material Code	05/28/16	J. C.

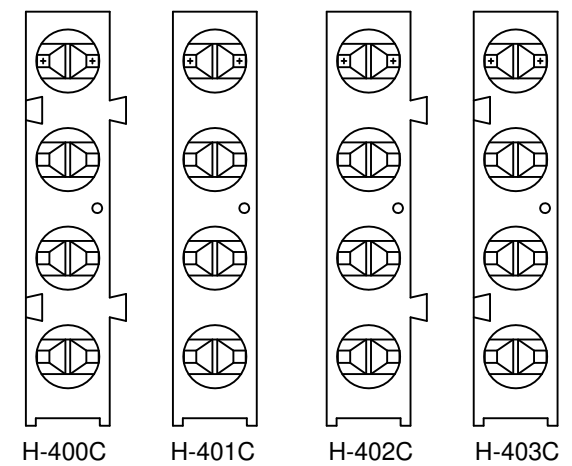
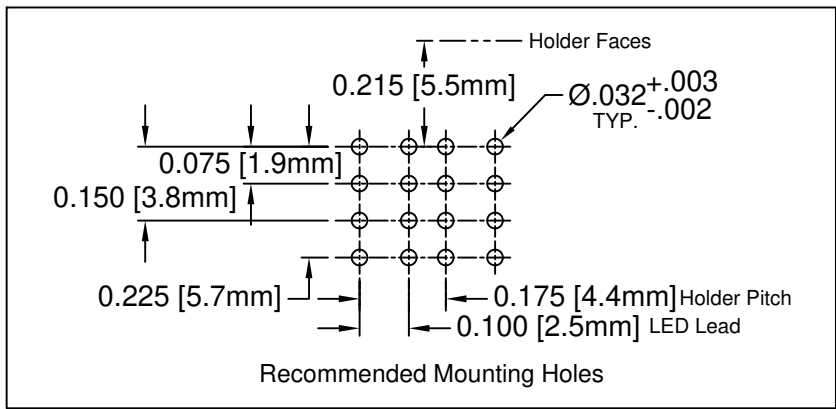
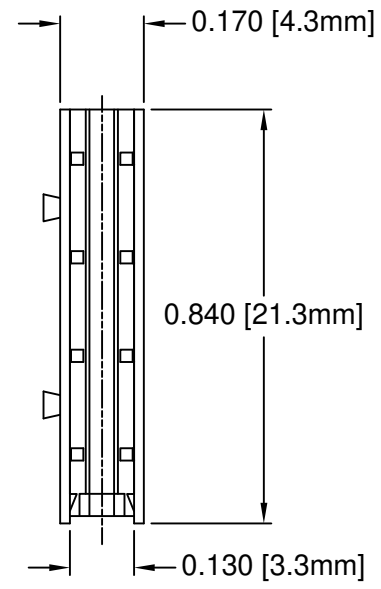
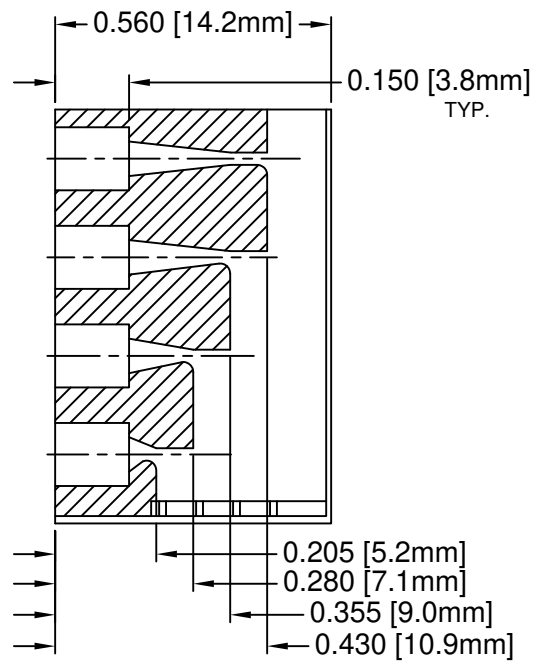
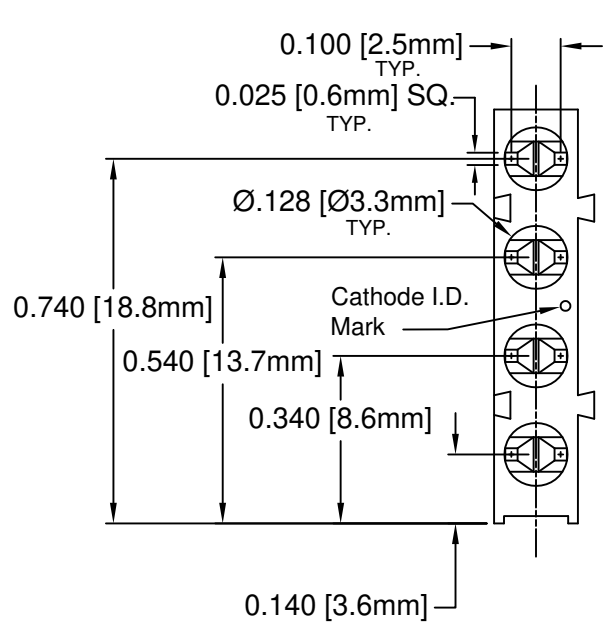

- 2. MATERIAL: NYLON 6/6, 94V-0, BLACK.
- 1. GENERAL SPECIFICATIONS: BIVAR MOLDED COMPONENT SPECIFICATION BV00-E101.

STANDARD TOLERANCE (UNLESS OTHERWISE SPECIFIED)		 4 THOMAS, IRVINE, CA. 92618 TEL: (949) 951-8808 FAX: (949) 951-3974	
DECIMALS	ANGULAR		
.X ±.1	X° ±1°		TITLE: QUAD-LEVEL T-1 (3mm) LED HOLDER INTERLOCKING
.XX ±.01			
.XXX ±.005		DESIGNED: D. Green CHECKED: M. Chen	DATE: 04/15/03 DATE: 04/15/03
		PART NO: H-40XC	REVISION: F
		CAGE CODE : 32559	SHEET # 1 OF 1
CAD GENERATED DOCUMENT. DO NOT MEASURE DRAWING.			