

IS31LT3380 MR16 Lighting Evaluation Board Guide

Description

The IS31LT3380 is a continuous mode inductive step-down converter, designed for driving a single LED or multiple series connected LEDs efficiently from a voltage source higher than the LED voltage. The chip operates from an input voltage between 8.5V and 40V and provides an output current up to 1.2A. The IS31LT3380 includes a high-side output current sensing circuit, which uses an external resistor to set the nominal average output current. The IS31LT3380 includes an integrated output switch which has a very low conducting impedance to ensure high system efficiency.

The IS31LT3380 has switch dimming function; the chip detects external switch action to adjust output current, allowing for dimming functionality to be achieved without changing the original lighting system circuitry. The switch dimming is implemented in either two-level mode or three-level mode. The output current of every level and the total number of levels are customer selected by setting the corresponding input conditions of DIM1 and DIM2 pin.

The output current is set at the initial value the first time that power is supplied to the chip. After the initial power up sequence, the chip adjusts the output current according to the external switch action. After the lowest current level, the current cycles back to the initial value if more switch action is detected. If the power is switched off for longer than 2 seconds, the device will return to its initial state, and the output current will be set to the initial value the next time that power is applied.

Features

- Multi-mode switch dimming
- Up to 1.2A output current
- High efficiency (up to 98%)
- Wide input voltage range: 8.5V to 40V
- Internal 40V power switch
- Typical 5% output current accuracy
- Inherent LED open/short-circuit protection
- Thermal shutdown protection circuitry

Applications

- MR16, MR11 LED spotlight
- LED street lighting
- PAR LED bulb

Quick Start

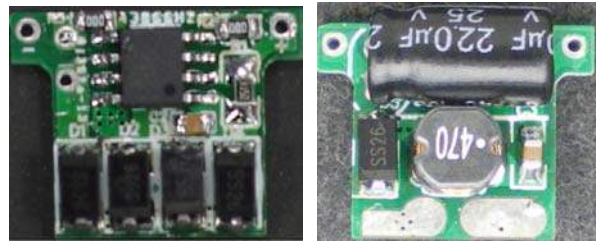

Recommended Equipment

- Power supply
- LED panel (LED arrays)
- Multimeter

Absolute Maximum Ratings

- $\leq 25\text{VAC}$ power supply

Caution: Do not exceed the conditions listed above, otherwise the board will be damaged.

Procedure

The IS31LT3380 Evaluation Board is fully assembled and tested. Follow the steps listed below to verify board operation.

Caution: Do not turn on the power supply until all connections are completed.

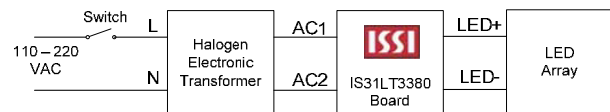

- 1) Connect the two terminals of the power supply to the AC1 and AC2 pin.
- 2) Connect the negative of the LED panel (LED arrays) to the LED- terminal.
- 3) Connect the positive of the LED panel (LED arrays) to the LED+ terminal.
- 4) Turn on the power supply and the LED panel (LED arrays) will be light.

Ordering Information

PART #	TEMP RANGE	IC PACKAGE
IS31LT3380_GRLS3_EBMR16	-40 °C to 105°C	SO-8 (5.0x6.0mm)

For pricing, delivery, and ordering information, please contact ISSI at analog_mkt@issi.com or call +1-408-969-6600

Detailed Description

LED Current Control

The nominal average output current in the LED(s) is determined by the value of the external current sense resistor (R_S) connected between V_{IN} and I_{SENSE} and is given by: $I_{OUT\ nom} = 0.1/R_S$

The table below gives values of nominal average output current for several preferred values of current setting resistor (R_S) in the application circuit:

R_S (Ω)	Nominal average output current (mA)
0.083	1200
0.15	667
0.3	333

R_S need to be chosen as a 1% accuracy resistor with enough power tolerance and good temperature characteristic to ensure stable output current.

Inductor selection

Recommended inductor values are in the range 47 μ H to 220 μ H. Higher values of inductance are recommended at higher supply voltages and low output current in order to minimize errors due to switching delays, which result in increased ripple and lower efficiency. Higher values of inductance also result in a smaller change in output current over the supply voltage range. The inductor should be mounted as

Setting Dimming Current-Level

Pin Name / Setting		DESCRIPTION	
DIM 1 (pin 6)	DIM 2 (pin 5)	Functionality	Dimming Levels
Floating	Floating	No Dimming	100%
Floating	GND	3 (Three) - levels of dimming	100% -- 50% -- 20%
GND	Floating	3 (Three) - levels of dimming	100% -- 60% -- 30%
GND	GND	2 (Two) - levels of dimming	100% -- 30%

The operation of the power switch and the configuration of the DIM1 and DIM2 pins control the dimming process as follows:

- When DIM1 and DIM2 pins are both floating, there is no switch dimming, and the output current is 100% of the programmed value when the power is on.
- When DIM1 is floating and DIM2 is GND, the output current is:
 - 100% at power on.
 - The first switch dimming action causes the current to change to 50%.
 - A second switch dimming action causes the current to return to 20%.
 - A fourth switch dimming action has the same effect as the first switch dimming action.
 - Subsequent switch dimming actions causes the cycle to continue.
- When DIM1 is GND and DIM2 is floating, the dimming sequence is as described in (2) above, except that the current sequence is 100%-60%-30%.
- When both DIM1 and DIM2 are connected to GND, the dimming sequence is as described in (2) above,

close to the LX pin as possible with low resistance connections to LX.

PCB layout consideration

VIN/GND pin

The GND of the power supply usually has some distance between it and the chip GND pin, causing parasitic resistance and inductance, resulting in ground voltage bounce when the MOSFET switches. To minimize ground bounce, the ground pin of the chip should be soldered directly to the ground plane. Connecting a 0.1 μ F capacitor between the VIN and GND pins as close to the chip as possible minimizes the effects of ground bounce.

LX pin

The LX pin of the chip is a fast switching node, so PCB traces should be kept as short as possible.

Coil and decoupling capacitors

It is particularly important to mount the coil and the input decoupling capacitor close to the chip to minimize parasitic resistance and inductance, which will degrade efficiency. It is also important to take account of any trace resistance in series with current sense resistor R_S (shown as R1 on schematic diagram).

DIM pin

The DIM pin is a high impedance input, when left floating this pin is pulled up to 3.3V by internal circuitry. Avoid running any high voltage traces close to the DIM pins.

IS31LT3380 MR16 Lighting Evaluation Board Guide

except that the current sequence is 100%-30%.

If the switch is operated normally, that is, switched ON once after being in the OFF position for a long time, or if

both the DIM1 and DIM2 pins are floating, then the output current always starts up at the initial value of 100%.

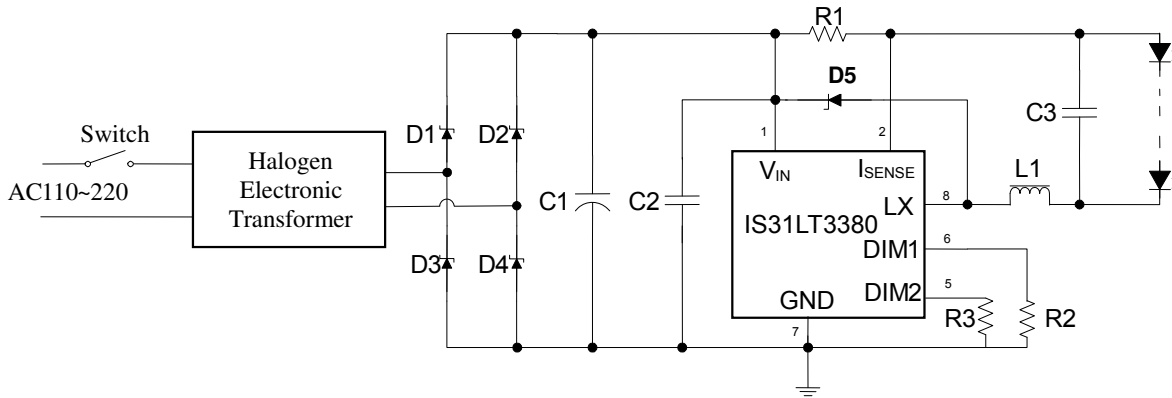

Figure 1 IS31LT3380 Evaluation Board Schematic

Note: ISSI Evaluation Board does not include an Electronic Transformer or LED array

Bill of Materials

No.	Name	Description	Ref Des.	Qty.	Mfr P/N
1	SMD Diode	2A,40V	D1-D5	5	
2	AL Capacitor	330uF,25V	C1	1	
3	SMD Capacitor	0.1uF,50V	C2	1	
4	SMD Capacitor	1uF,250V	C3	2	
5	SMD Resistor	0.15Ω,(1206),1%	R1 (R _S)	1	
6	SMD Resistor	0Ω,(0805)	R2	1	
7	SMD Resistor	0Ω,(0805)	R3	1	
8	SMD Inductor	47μH,I _{sat} >1000mA	L1	1	
9	IC	IS31LT3380	U1	1	

PCB Layout

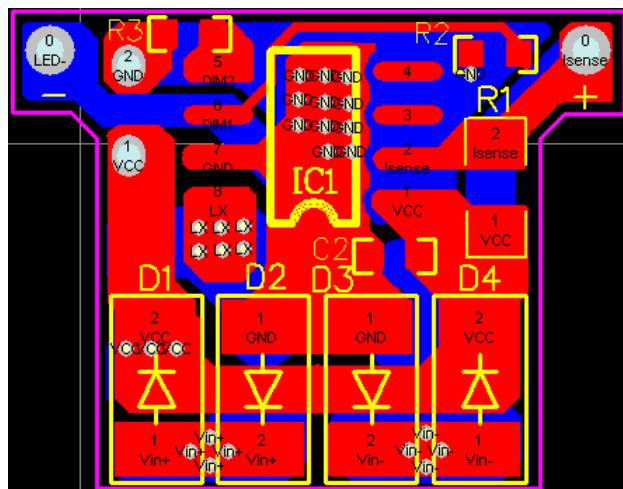

Figure 2 PCB Layout- Top Layer

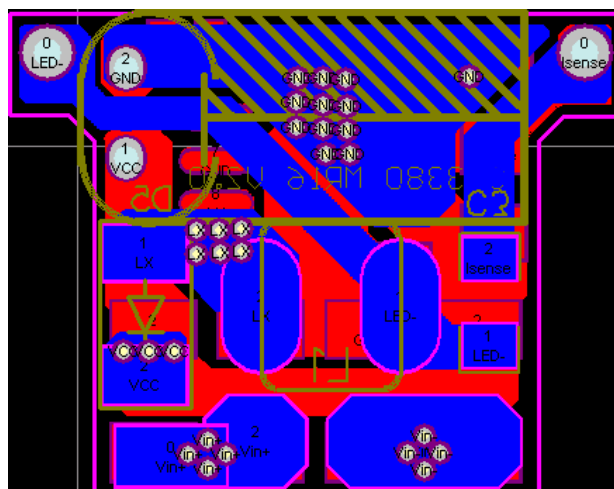

Figure 3 PCB Layout-Bottom Layer

Copyright © 2011 Integrated Silicon Solution, Inc. All rights reserved. ISSI reserves the right to make changes to this specification and its products at any time without notice. ISSI assumes no liability arising out of the application or use of any information, products or services described herein. Customers are advised to obtain the latest version of this device specification before relying on any published information and before placing orders for products.

Integrated Silicon Solution, Inc. does not recommend the use of any of its products in life support applications where the failure or malfunction of the product can reasonably be expected to cause failure of the life support system or to significantly affect its safety or effectiveness. Products are not authorized for use in such applications unless Integrated Silicon Solution, Inc. receives written assurance to its satisfaction, that:

- the risk of injury or damage has been minimized;
- the user assume all such risks; and
- potential liability of Integrated Silicon Solution, Inc is adequately protected under the circumstances