

USB-serial dual channel (UART/I²C/SPI) bridge with CAPSENSE™ and BCD

Features

- USB 2.0 certified, Full-Speed (12 Mbps)
 - Support for communication driver class (CDC), personal health care device class (PHDC), and vendor device class
 - Battery charger detection (BCD) compliant with USB Battery Charging Specification Rev 1.2 (Peripheral Detect only)
 - Integrated USB termination resistors
- Two-channel configurable UART interfaces
 - CY7C65215 supports 2-pin, 4-pin and 6-pin UART interface whereas CY7C65215A supports 2-pin, 4-pin, 6-pin and 8-pin UART interface
 - Data rates up to 3 Mbps
 - 190 bytes each transmit and receive buffer per channel
 - Data format:
 - 7 or 8 data bits
 - 1 or 2 stop bits
 - No parity, even, odd, mark, or space parity
 - Supports parity, overrun, and framing errors
 - Supports flow control using CTS, RTS, DTR, DSR
 - Supports UART break signal
 - CY7C65215 supports dual channel RS232/RS422 interfaces whereas CY7C65215A supports RS232/RS422/RS485 interfaces
- Two-channel configurable SPI interfaces
 - Data rate up to 3 MHz for SPI master and 1 MHz for SPI slave
 - Data width: 4 bits to 16 bits
 - 256 bytes for each transmit and receive buffer per channel
 - Supports Motorola, TI, and National SPI modes
- Two-channel configurable I²C interfaces
 - Master/slave up to 400 kHz
 - Supports multi-master I²C
 - 256 bytes for each transmit and receive buffer per channel
- CAPSENSE™
 - SmartSense™ Auto-Tuning is supported through a Cypress-supplied configuration utility
 - Max CAPSENSE™ buttons: 8
 - GPIOs linked to CAPSENSE™ buttons
- JTAG interface: JTAG master for code flashing at 400 kHz
- General-purpose input/output (GPIO) pins: 17
- Supports unique serial number feature for each device, which fixes the COM port number permanently when USB-Serial Bridge controller as CDC device plugs in
- Configuration utility (Windows) to configure the following:
 - Vendor ID (VID), Product ID (PID), and Product and Manufacturer descriptors
 - UART/I²C/SPI/JTAG
 - CAPSENSE™
 - Charger detection
 - GPIO

Features

- Driver support for VCOM and DLL
 - Windows 10: 32- and 64-bit versions
 - Windows 8.1: 32- and 64-bit versions
 - Windows 8: 32- and 64-bit versions
 - Windows 7: 32- and 64-bit versions
 - Windows Vista: 32- and 64-bit versions
 - Windows XP: 32- and 64-bit versions
 - Windows CE
 - Mac OS-X: 10.6, and later versions
 - Linux: Kernel version 2.6.35 onwards
 - Android: Gingerbread and later versions
- Clocking: Integrated 48-MHz clock oscillator
- Supports bus-/self-powered configurations
- USB suspend mode for low power
- Operating voltage: 1.71 to 5.5 V
- Operating temperature:
 - Commercial: 0°C to 70°C
 - Industrial: -40°C to 85°C
- ESD protection: 2.2 kV HBM
- RoHS compliant package
 - 32-pin QFN (5 × 5 × 1 mm, 0.5 mm pitch)
- Ordering part number
 - CY7C65215-32LTXI

Applications

- Medical/healthcare devices
- Point-of-Sale (POS) terminals
- Test and measurement system
- Gaming systems
- Set-top box PC-USB interface
- Industrial
- Networking
- Enabling USB connectivity in legacy peripherals

USB Compliant

The USB-Serial Dual-Channel Bridge with CAPSENSE™ and BCD (CY7C65215/CY7C65215A) is fully compliant with the USB 2.0 specification and Battery Charging Specification v1.2, USB-IF Test-ID (TID) 40001521.



USB-Serial Dual Channel (UART/I²C/SPI) Bridge with CAPSENSE™ and BCD



CY7C65215 and CY7C65215A features comparison

CY7C65215 and CY7C65215A features comparison

Table 1 CY7C65215 and CY7C65215A features comparison

Features	CY7C65215	CY7C65215A
UART	Can be configured as Virtual COM port or USB vendor device	Can be configured as Virtual COM port or USB vendor device
I ² C	Can be configured as USB vendor device	Can be configured as Virtual COM port or USB vendor device
SPI	Can be configured as USB vendor device	Can be configured as Virtual COM port or USB vendor device
RS485 Support	No	Yes
8-pin UART Support	No	Yes
JTAG Support	Yes	No

More Information

More Information

Cypress provides a wealth of data at www.cypress.com to help you to select the right device for your design, and to help you to quickly and effectively integrate the device into your design. For a comprehensive list of resources, see the document [USB-Serial Bridge Controller Product Overview](#).

- Overview: [USB Portfolio](#), [USB Roadmap](#)
- USB 2.0 Product Selectors: [USB-Serial Bridge Controller](#), [USB to UART Controller \(Gen I\)](#)
- Knowledge Base Articles: Cypress offers a large number of USB knowledge base articles covering a broad range of topics, from basic to advanced level. Recommended knowledge base articles for getting started with USB-Serial Bridge Controller are:
 - [KBA85909](#) – Key Features of the Cypress® USB-Serial Bridge Controller
 - [KBA85920](#) – USB-UART and USB-Serial
 - [KBA85921](#) – Replacing FT232R with CY7C65213 USB-UART LP Bridge Controller
 - [KBA85913](#) – Voltage supply range for USB-Serial
 - [KBA89355](#) – USB-Serial: Cypress Default VID and PID
 - [KBA92641](#) – USB-Serial Bridge Controller Managing I/Os using API
 - [KBA92442](#) – Non-Standard Baud Rates in USB-Serial Bridge Controllers
 - [KBA91366](#) – Binding a USB-Serial Device to a Microsoft® CDC Driver
 - [KBA92551](#) – Testing a USB-Serial Bridge Controller Configured as USB-UART with Linux®
 - [KBA91299](#) – Interfacing an External I2C Device with the CYUSBS234/236 DVK

For a complete list of knowledge base articles, click [here](#).

- Code Examples: [USB Full-Speed](#)
- Development Kits:
 - [CYUSBS232](#), Cypress USB-UART LP Reference Design Kit
 - [CYUSBS234](#), Cypress USB-Serial (Single Channel) Development Kit
 - [CYUSBS236](#), Cypress USB-Serial (Dual Channel) Development Kit

- Models: [IBIS](#)

Cypress USB-Serial (Dual Channel) Development Kit

The [Cypress USB-Serial \(Dual Channel\) Development Kit](#) is a complete development resource. It provides a platform to develop and test custom projects. The development kit contains collateral materials for the firmware, hardware, and software aspects of a design.

Table of contents

Features	1
Applications	3
CY7C65215 and CY7C65215A features comparison	4
More Information	5
Table of contents	6
Block diagram	7
Functional overview	8
USB and charger detect	8
Serial communication	9
CAPSENSE™	10
JTAG interface	10
GPIO interface	11
Memory	11
System resources	11
Suspend and Resume	12
WAKEUP	12
Software	12
Internal Flash configuration	14
Electrical specifications	15
Absolute maximum ratings	15
Operating conditions	15
Device level specifications	16
GPIO	17
nXRES	19
SPI specifications	20
I2C specifications	23
JTAG specifications	23
CAPSENSE™ specifications	23
Flash memory specifications	23
Pin description	24
USB power configurations	29
USB bus-powered configuration	29
Self-powered configuration	30
USB bus powered with variable I/O voltage	31
Application examples	32
USB-to-dual UART bridge with battery-charge detection	32
USB to RS485 application	35
CAPSENSE™	36
USB to dual channel (I2C/SPI) bridge	37
Ordering information	43
Ordering code definitions	43
Package information	44
Acronyms	45
Document conventions	46
Units of measure	46
Errata	47
Revision history	50

Block diagram

1 Block diagram

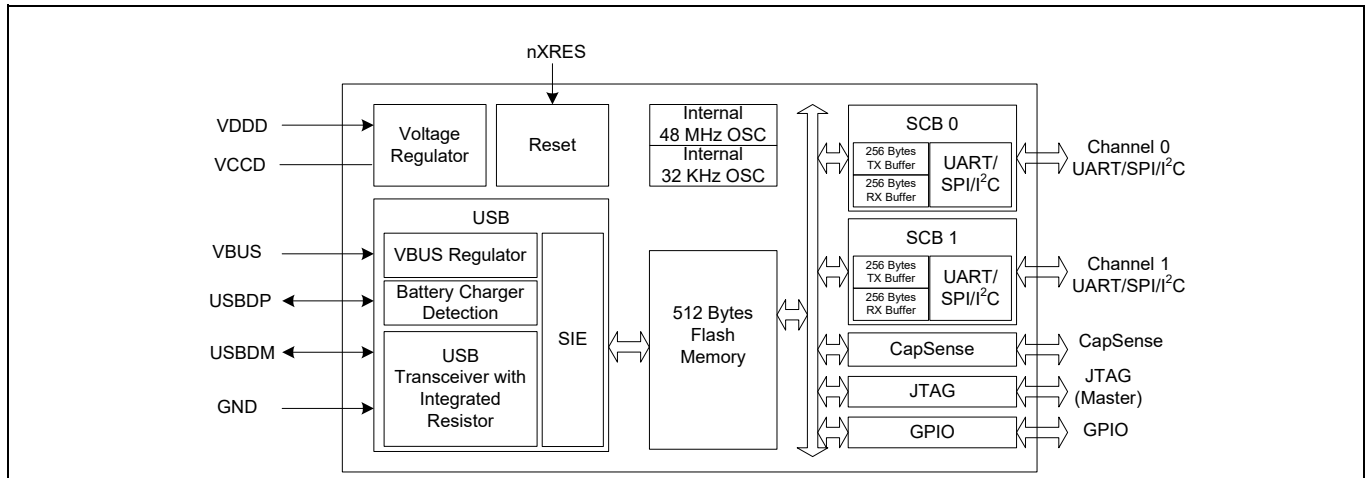

2 Functional overview

The CY7C65215/CY7C65215A is a Full-Speed USB controller that enables seamless PC connectivity for peripherals with dual-channel serial interfaces such as UART, SPI, and I²C. CY7C65215/CY7C65215A also integrates CAPSENSE™ and BCD, which is compliant with the USB Battery Charging Specification Rev. 1.2. It integrates a voltage regulator, oscillator, and flash memory for storing configuration parameters, offering a cost-effective solution. CY7C65215/CY7C65215A supports bus-powered and self-powered modes, and enables efficient system power management with suspend and remote wake-up signals. It is available in a 32-pin QFN package.

2.1 USB and charger detect

2.1.1 USB

CY7C65215/CY7C65215A has a built-in USB 2.0 Full-Speed transceiver. The transceiver incorporates the internal USB series termination resistors on the USB data lines and a 1.5-k Ω pull-up resistor on USBDP.

2.1.2 Charger detection

CY7C65215/CY7C65215A supports BCD for Peripheral Detect only and complies with the USB Battery Charging Specification Rev. 1.2. It supports the following charging ports:

- Standard Downstream Port (SDP): allows the system to draw up to 500 mA current from the host
- Charging Downstream Port (CDP): allows the system to draw up to 1.5 A current from the host
- Dedicated Charging Port (DCP): allows the system to draw up to 1.5 A of current from the wall charger

2.2 Serial communication

CY7C65215/CY7C65215A has two serial communication blocks (SCBs). Each SCB can implement UART, SPI, or an I²C interface. A 256-byte buffer is available in both the TX and RX lines.

Table 2 shows maximum speed supported on both SCBs when they are configured as UART/I2C/SPI.

Table 2 Maximum Speed supported on both SCBs

No.	Configuration	SCB0 Maximum Speed	SCB1 Maximum Speed
1	SCB0 = UART, SCB1 = Disabled	3M (Either TX/RX)	NA
2	SCB0 = I2C Master, SCB1 = Disabled	400 kHz (Both TX and RX)	NA
3	SCB0 = I2CSlave, SCB1 = Disabled	400 kHz (Both TX and RX)	NA
4	SCB0 = SPI Master, SCB1 = Disabled	3M (Both TX and RX)	NA
5	SCB0 = SPI Slave, SCB1 = Disabled	1M (Both TX and RX)	NA
6	SCB0 = UART, SCB1 = UART	1M (Either TX/RX)	1M (Either TX/RX)
7	SCB0 = UART, SCB1 = I2C Master	1M (Either TX/RX)	400 kHz (Both TX and RX)
	SCB0 = I2C Master, SCB1 = UART		
8	SCB0 = UART, SCB1 = I2C Slave	1M (Either TX/RX)	400 kHz (Both TX and RX)
	SCB0 = I2C slave, SCB1 = UART		
9	SCB0 = UART, SCB1 = SPI Master	1M (Either TX/RX)	1M (Both TX and RX)
	SCB1 = SPI Master, SCB0 = UART		
10	SCB0 = UART, SCB1 = SPI Slave	1M (Either TX/RX)	1M (Both TX and RX)
	SCB0 = SPI Slave, SCB1 = UART		
11	SCB0 = I2C, SCB1 = I2C	400 kHz (Both TX and RX)	400 kHz (Both TX and RX)
12	SCB0 = SPI, SCB1 = SPI	1M (Both TX and RX)	1M (Both TX and RX)

2.2.1 UART interface

The UART interface provides asynchronous serial communication with other UART devices operating at speeds of up to 3 Mbps. It supports 7 to 8 data bits, 1 to 2 stop bits, odd, even, mark, space, and no parity. The UART interface supports full duplex communication with a signaling format that is compatible with the standard UART protocol. In CY7C65215, UART pins may be interfaced to industry standard RS232/RS422 transceivers whereas in CY7C65215A these UART pins may be interfaced to RS232/RS422/RS485.

CY7C65215/CY7C65215A supports common UART functions such as parity error and frame error. In addition, CY7C65215/CY7C65215A supports baud rates ranging from 300 baud to 3 Mbaud. UART baud rates can be set using the configuration utility.

Notes:

Parity error gets detected when UART transmitter device is configured for odd parity and UART receiver device is configured for even parity.

Frame error gets detected when UART transmitter device is configured for 7 bits data width and 1 stop bit, whereas UART receiver device is configured for 8 bit data width and 2 stop bits.

2.2.2 UART flow control

The CY7C65215/CY7C65215A device supports UART hardware flow control using control signal pairs such as RTS# (Request to Send) / CTS# (Clear to Send) and DTR# (Data Terminal Ready) / DSR# (Data Set Ready). Data flow control is enabled by default. Flow control can be disabled using the configuration utility.

The following section describes the flow control signals:

- CTS# (Input) / RTS# (Output)

CTS# can pause or resume data transmission over the UART interface. Data transmission can be paused by de-asserting the CTS signal and resumed with CTS# assertion. The pause and resume operation does not affect data integrity. With flow control enabled, receive buffer has a watermark level of 93%. After the data in the receive buffer reaches that level, the RTS# signal is de-asserted, instructing the transmitting device to stop data transmission. The start of data consumption by the application reduces device data backlog. When it reaches the 75% watermark level, the RTS# signal is asserted to resume data reception.

- DSR# (Input) / DTR# (Output)

DSR#/DTR# signals are used to establish the communication link with the UART. These signals complement each other in their functionality, similar to CTS# and RTS#.

2.2.3 SPI interface

The SPI interface supports SPI Master and SPI Slave. This interface supports the Motorola, TI, and National Microwire protocols. The maximum frequency of operation is 3 MHz in SPI master mode and 1 MHz in SPI slave mode. It can support transaction sizes ranging from 4 bits to 16 bits in length, SPI slave supports 4 bits to 8 bits and 12 bits to 16 bits data width at 1 MHz operation. Whereas, it supports 9 bits, 10 bits and 11 bits data width operation at 500 kHz operation (for more details, refer to “[USB to dual channel \(I2C/SPI\) bridge](#)” on page 37).

2.2.4 I²C interface

The I²C interface implements full multi-master/slave modes and supports up to 400 kHz. The configuration utility tool is used to set the I²C address in slave mode. This tool enables only even slave addresses. For further details on protocol, refer to the NXP I²C specification rev5.

Notes

- I²C ports are not tolerant of higher voltages and cannot be hot-swapped or powered up independently from the rest of the I²C system.
- The minimum fall time of the SCL is met (as per NXP I2C specification Rev. 5) when V_{DD} is between 1.71 V and 3.0 V. When V_{DD} is within the range of 3.0 V to 3.6 V, it is recommended to add a 50 pF capacitor on the SCL signal.

2.3 CAPSENSE™

CAPSENSE™ functionality is supported on all the GPIO pins. Any GPIO pin can be configured as a sense pin (CS0–CS7) using the configuration utility. When implementing CAPSENSE™ functionality, the GPIO_0 pin (configured as the modulator capacitor - Cmod) should be connected to ground through a 2.2-nF capacitor (see [Figure 12](#)). CY7C65215/CY7C65215A supports SmartSense auto-tuning of CAPSENSE™ parameters and does not require manual tuning. SmartSense auto-tuning compensates for printed circuit board (PCB) variations and device process variations.

Optionally, any GPIO pin can be configured as a Cshield and connected to the shield of the CAPSENSE™ button as shown in [Figure 12](#). The shield prevents false triggering of buttons due to water droplets and guarantees CAPSENSE™ operation (sensors respond to finger touch). GPIOs can be linked to CAPSENSE™ buttons to indicate the presence of a finger. CAPSENSE™ functionality can be configured using configuration utility.

CY7C65215/CY7C65215A supports up to eight CAPSENSE™ buttons. For more information on CAPSENSE™, refer to [Getting Started with CAPSENSE™](#).

2.4 JTAG interface

CY7C65215/CY7C65215A supports a 5-pin JTAG in master mode for code flashing at 400 kHz.

Note: When JTAG is enabled, other interfaces in the CY7C65215/CY7C65215A device cannot be used.

2.5 GPIO interface

CY7C65215/CY7C65215A has 17 GPIOs. A maximum of 17 GPIOs are available for configuration if one 2-pin (I²C/2-pin UART) serial interface is implemented. The configuration utility allows configuration of the GPIO pins. The configurable options are as follows:

- TRISTATE: GPIO tristated
- DRIVE 1: Output static 1
- DRIVE 0: Output static 0
- POWER#: Power control for bus power designs
- TXLED#: Drives LED during USB transmit
- RXLED#: Drives LED during USB receive
- TX or RX LED#: Drives LED during USB transmit or receive
GPIO can be configured to drive LED at 8-mA drive strength.
- BCD0/BCD1: Two-pin output to indicate the type of USB charger
- BUSDETECT: Connects VBUS pin for USB host detection
- CS0–CS7: CAPSENSE™ button input (Sense pin)
- CSout0–CSout3: Indicates which CAPSENSE™ button is pressed
- Cmod: External modulator capacitor that connects a 2.2-nF capacitor ($\pm 10\%$) to ground (GPIO_0 only)
- Cshield: Shield for waterproofing

2.6 Memory

CY7C65215/CY7C65215A has a 512-byte flash. The flash is used to store the USB parameters such as VID/PID, serial number, Product, and Manufacturer Descriptors, which can be programmed by the configuration utility.

2.7 System resources

2.7.1 Power system

CY7C65215/CY7C65215A supports the USB Suspend mode to control power usage. CY7C65215/CY7C65215A operates in bus-powered or self-powered modes over a range of 3.15 to 5.5 V.

2.7.2 Clock system

CY7C65215/CY7C65215A has a fully integrated clock and does not require any external components. The clock system is responsible for providing clocks to all subsystems.

2.7.3 Internal 48-MHz oscillator

The internal 48-MHz oscillator is the primary source of internal clocking in CY7C65215/CY7C65215A.

2.7.4 Internal 32-kHz oscillator

The internal 32-kHz oscillator is primarily used to generate clocks for peripheral operation in the USB Suspend mode.

2.7.5 Reset

The reset block ensures reliable power-on reset and brings the device back to the default known state. The nXRES (active low) pin can be used by external devices to reset the CY7C65215/CY7C65215A.

2.8 Suspend and Resume

The CY7C65215/CY7C65215A device asserts the SUSPEND pin when the USB bus enters the suspend state. This helps in meeting the stringent suspend current requirement of the USB 2.0 specification, while using the device in bus-powered mode. The device will resume from the suspend state under any of the following conditions:

1. Any activity is detected on the USB bus
2. The WAKEUP pin is asserted to generate remote wakeup to the host

2.9 WAKEUP

The WAKEUP pin is used to generate a remote wakeup signal on the USB bus. The remote wakeup signal is sent only if the host enables this feature through the SET_FEATURE request. The device communicates support for the remote wakeup to the host through the configuration descriptor during the USB enumeration process. The CY7C65215/CY7C65215A device allows enabling/disabling and polarity of the remote wakeup feature through the configuration utility.

2.10 Software

Cypress delivers a complete set of software drivers and the configuration utility to enable product configuration during system development.

2.10.1 Drivers for Linux operating systems

Cypress provides a User Mode USB driver library (*libcyusbserial.so*) that abstracts vendor commands for the UART interface and provides a simplified API interface to the user applications. This library makes use of the standard open source libUSB library to enable the USB communication. The Cypress serial library supports the USB plug-and-play feature using the Linux ‘udev’ mechanism.

CY7C65215/CY7C65215A supports the standard USB CDC UART class driver, which is bundled with the Linux kernel.

2.10.2 Android support

The CY7C65215/CY7C65215A solution includes an Android Java class—*CyUsbSerial.java*—which exposes a set of interface functions to communicate with the device.

2.10.3 Drivers for Mac OSx

Cypress delivers a dynamically linked shared library (*CyUSBSerial.dylib*) based on libUSB, which enables communication to the CY7C65215/CY7C65215A device.

In addition, the CY7C65215 device also supports the native Mac OSx CDC UART driver, and CY7C65215A supports native Mac OSx CDC UART/SPI/I2C driver.

2.10.4 Drivers for Windows operating systems

For Windows operating systems (XP, Vista, Win7, Win8, and Win8.1), Cypress delivers a User Mode dynamically linked library—*CyUSBSerial DLL*—that abstracts vendor-specific interface of CY7C65215/CY7C65215A devices and provides convenient APIs to the user. It provides interface APIs for vendor-specific UART/SPI/I2C and class-specific APIs for PHDC.

USB-Serial Bridge Controller works with the Windows-standard USB CDC class driver, when either CY7C65215 is configured as CDC USB to UART device or when CY7C65215A is configured as CDC USB to UART/SPI/I2C device. A virtual COM port driver—*CyUSBSerial.sys*—is also delivered, which implements the USB CDC class driver. The Cypress Windows drivers are Windows hardware certification kit-compliant.

These drivers are bound to device through WU (Windows Update) services.

Cypress drivers also support Windows plug-and-play and power management and USB Remote Wake-up.

2.10.5 Windows-CE support

The CY7C65215/CY7C65215A solution includes a CDC UART driver library for Windows-CE platforms.

Device Configuration Utility (Windows only)

A Windows-based configuration utility is available to configure various device initialization parameters. This graphical user application provides an interactive interface to define the various boot parameters stored in the device flash.

This utility allows the user to save a user-selected configuration to text or xml formats. It also allows users to load a selected configuration from text or xml formats. The configuration utility allows the following operations:

- View current device configuration
- Select and configure UART/I2C/SPI, CAPSENSE™, battery charging, and GPIOs
- Configure USB VID, PID, and string descriptors
- Save or Load configuration

You can download the free configuration utility and drivers from www.cypress.com.

2.11 Internal Flash configuration

The internal flash memory can be used to store the configuration parameters shown in the following table. A free configuration utility is provided to configure the parameters listed in the table to meet application specific requirements over USB interface. The configuration utility can be downloaded from www.cypress.com/go/usbserial.

Table 3 Internal Flash configuration for both CY7C65215 and CY7C65215A

Parameter	Default value	Description
USB Configuration		
USB Vendor ID (VID)	0x04B4	Default Cypress VID. Can be configured to customer VID
USB Product ID (PID)	0x0005	Default Cypress PID. Can be configured to customer PID
Manufacturer string	Cypress	Can be configured with any string up to 64 characters
Product string	USB-Serial (Dual Channel)	Can be configured with any string up to 64 characters
Serial string		Can be configured with any string up to 64 characters
Power mode	Bus powered	Can be configured to bus-powered or self-powered mode
Max current draw	100 mA	Can be configured to any value from 0 to 500 mA. Based on this, the configuration descriptor will be updated.
Remote wakeup	Enabled	Can be disabled. Remote wakeup is initiated by asserting WAKEUP pin
USB interface protocol	CDC	Can be configured to function in CDC, PHDC, or Cypress vendor class
BCD	Disabled	Charger detect is disabled by default. When BCD is enabled, three of the GPIOs must be configured for BCD
GPIO Configuration		
GPIO_0	TXLED#	GPIO can be configured as shown in Table 19 on page 28 .
GPIO_1	RXLED#	
GPIO_2	DSR#_0	
GPIO_3	RTS#_0	
GPIO_4	CTS#_0	
GPIO_5	TxD_0	
GPIO_6	POWER#	
GPIO_7	TRISTATE	
GPIO_8	RxD_0	
GPIO_9	DTR#_0	
GPIO_10	RxD_1	
GPIO_11	TxD_1	
GPIO_12	RTS#_1	
GPIO_13	CTS#1	
GPIO_14	DSR#_1	
GPIO_15	DTR#_1	
GPIO_16	TRISTATE	
GPIO_17	TRISTATE	
GPIO_18	TRISTATE	

3 Electrical specifications

3.1 Absolute maximum ratings

Exceeding maximum ratings ^[1] may shorten the useful life of the device.

Storage temperature -55°C to +100°C

Ambient temperature with power supplied (Industrial) -40°C to +85°C

Supply voltage to ground potential

V_{DDD} 6.0 V

V_{BUS} 6.0 V

V_{CCD} 1.95 V

V_{GPIO} V_{DDD} + 0.5 V

Static discharge voltage ESD protection levels:

- 2.2-kV HBM per JESD22-A114

Latch-up current 140 mA

Current per GPIO 25 mA

3.2 Operating conditions

T_A (ambient temperature under bias)

Industrial -40°C to +85°C

V_{BUS} supply voltage 3.15 V to 5.25 V

V_{DDD} supply voltage 1.71 V to 5.50 V

V_{CCD} supply voltage 1.71 V to 1.89 V

Note

1. Usage above the absolute maximum conditions may cause permanent damage to the device. Exposure to Absolute Maximum conditions for extended periods of time may affect device reliability. When used below Absolute Maximum conditions but above normal operating conditions the device may not operate to specification.

3.3 Device level specifications

All specifications are valid for $-40^{\circ}\text{C} \leq T_A \leq 85^{\circ}\text{C}$, $T_J \leq 100^{\circ}\text{C}$, and 1.71 V to 5.50 V, except where noted.

Table 4 DC specifications

Parameter	Description	Min	Typ	Max	Units	Details/conditions
V _{BUS}	V _{BUS} supply voltage	3.15	3.30	3.45	V	Set and configure correct voltage range using the configuration utility for V _{BUS} .
		4.35	5.00	5.25	V	
V _{DDD}	V _{DDD} supply voltage	1.71	1.80	1.89	V	Used to set I/O and core voltage. Set and configure correct voltage range using the configuration utility for V _{DDD} .
		2.0	3.3	5.5	V	
V _{CCD}	Output voltage (for core logic)	–	1.80	–	V	Do not use this supply to drive external device. <ul style="list-style-type: none"> 1.71 V ≤ V_{DDD} ≤ 1.89 V: Short the V_{CCD} pin with the V_{DDD} pin V_{DDD} > 2 V – connect a 1-μF capacitor (C_{efc}) between the V_{CCD} pin and ground
C _{efc}	External regulator voltage bypass	1.00	1.30	1.60	μF	X5R ceramic or better
I _{DD1}	Operating supply current	–	13	18	mA	USB 2.0 FS, UART at 1 Mbps single channel, no GPIO switching at V _{BUS} = 5 V, V _{DDD} = 5 V
I _{DD2}	USB Suspend supply current	–	5	–	μA	Does not include current through a pull-up resistor on USBDP. In USB suspend mode, the D+ voltage can go up to a maximum of 3.8 V.

Table 5 AC specifications

Parameter	Description	Min	Typ	Max	Units	Details/conditions
Z _{out}	USB driver output impedance	28	–	44	Ω	
T _{wakeup}	Wakeup from USB Suspend mode	–	25	–	μs	

3.4 GPIO

Table 6 GPIO DC specification

Parameter	Description	Min	Typ	Max	Units	Details/conditions
V _{IH} ^[2]	Input voltage high threshold	0.7 × V _{DDD}	–	–	V	CMOS Input
V _{IL}	Input voltage low threshold	–	–	0.3 × V _{DDD}	V	CMOS Input
V _{IH} ^[2]	LVTTL input, V _{DDD} < 2.7 V	0.7 × V _{DDD}	–	–	V	
V _{IL}	LVTTL input, V _{DDD} < 2.7 V	–	–	0.3 × V _{DDD}	V	
V _{IH} ^[2]	LVTTL input, V _{DDD} ≥ 2.7 V	2	–	–	V	
V _{IL}	LVTTL input, V _{DDD} ≥ 2.7 V	–	–	0.8	V	
V _{OH}	CMOS output voltage high level	V _{DDD} – 0.4	–	–	V	I _{OH} = 4 mA, V _{DDD} = 5 V ± 10%
V _{OH}	CMOS output voltage high level	V _{DDD} – 0.6	–	–	V	I _{OH} = 4 mA, V _{DDD} = 3.3 V ± 10%
V _{OH}	CMOS output voltage high level	V _{DDD} – 0.5	–	–	V	I _{OH} = 1 mA, V _{DDD} = 1.8 V ± 5%
V _{OL}	CMOS output voltage low level	–	–	0.4	V	I _{OL} = 8 mA, V _{DDD} = 5 V ± 10%
V _{OL}	CMOS output voltage low level	–	–	0.6	V	I _{OL} = 8 mA, V _{DDD} = 3.3 V ± 10%
V _{OL}	CMOS output voltage low level	–	–	0.6	V	I _{OL} = 4 mA, V _{DDD} = 1.8 V ± 5%
R _{pullup}	Pull-up resistor	3.5	5.6	8.5	kΩ	
R _{pulldown}	Pull-down resistor	3.5	5.6	8.5	kΩ	
I _{IL}	Input leakage current (absolute value)	–	–	2	nA	25 °C, V _{DDD} = 3.0 V
C _{IN}	Input capacitance	–	–	7	pF	
V _{hystttl}	Input hysteresis LVTTL; V _{DDD} > 2.7 V	25	40	–	mV	
V _{hyscmos}	Input hysteresis CMOS	0.05 × V _{DDD}	–	–	mV	

Note

2. V_{IH} must not exceed V_{DDD} + 0.2 V.

Table 7 GPIO AC specification

Parameter	Description	Min	Typ	Max	Units	Details/conditions
T _{RiseFast1}	Rise Time in Fast mode	2	–	12	ns	V _{DDD} = 3.3 V/ 5.5 V, Cload = 25 pF
T _{FallFast1}	Fall Time in Fast mode	2	–	12	ns	V _{DDD} = 3.3 V/ 5.5 V, Cload = 25 pF
T _{RiseSlow1}	Rise Time in Slow mode	10	–	60	ns	V _{DDD} = 3.3 V/ 5.5 V, Cload = 25 pF
T _{FallSlow1}	Fall Time in Slow mode	10	–	60	ns	V _{DDD} = 3.3 V/ 5.5 V, Cload = 25 pF
T _{RiseFast2}	Rise Time in Fast mode	2	–	20	ns	V _{DDD} = 1.8 V, Cload = 25 pF
T _{FallFast2}	Fall Time in Fast mode	20	–	100	ns	V _{DDD} = 1.8 V, Cload = 25 pF
T _{RiseSlow2}	Rise Time in Slow mode	2	–	20	ns	V _{DDD} = 1.8 V, Cload = 25 pF
T _{FallSlow2}	Fall Time in Slow mode	20	–	100	ns	V _{DDD} = 1.8 V, Cload = 25 pF

Electrical specifications

3.5 nXRES

Table 8 nXRES DC specifications

Parameter	Description	Min	Typ	Max	Units	Details/conditions
V _{IH}	Input voltage high threshold	0.7 × V _{DD}	–	–	V	
V _{IL}	Input voltage low threshold	–	–	0.3 × V _{DD}	V	
R _{pullup}	Pull-up resistor	3.5	5.6	8.5	kΩ	
C _{IN}	Input capacitance	–	5	–	pF	
V _{hysxres}	Input voltage hysteresis	–	100	–	mV	

Table 9 nXRES AC specifications

Parameter	Description	Min	Typ	Max	Units	Details/conditions
T _{resetwidth}	Reset pulse width	1	–	–	μs	

Table 10 UART AC specifications

Parameter	Description	Min	Typ	Max	Units	Details/conditions
F _{UART}	UART bit rate	0.3	–	3000	kbps	Single SCB: TX + RX Dual SCB: TX or RX

3.6 SPI specifications

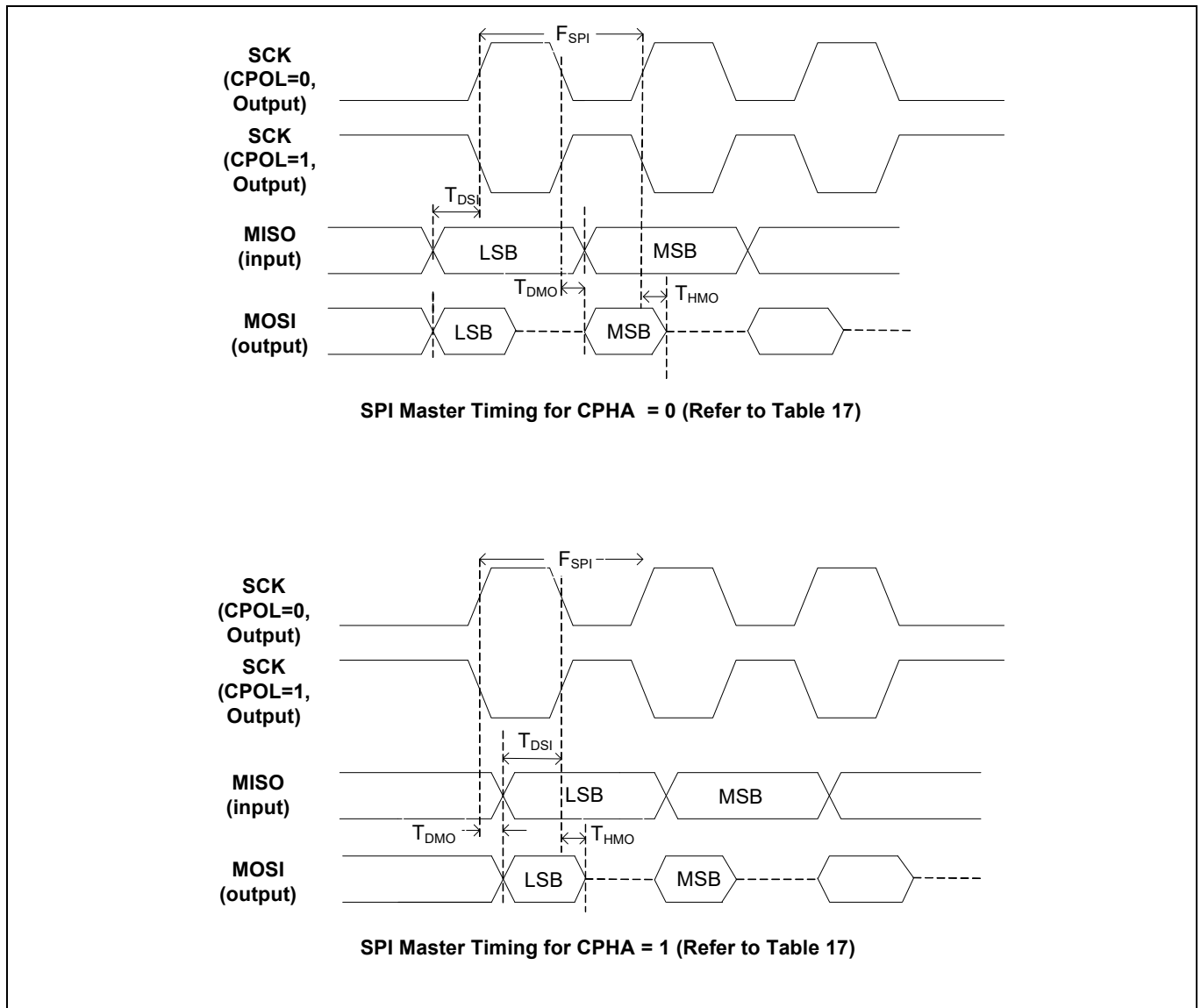

Figure 1 SPI Master timing

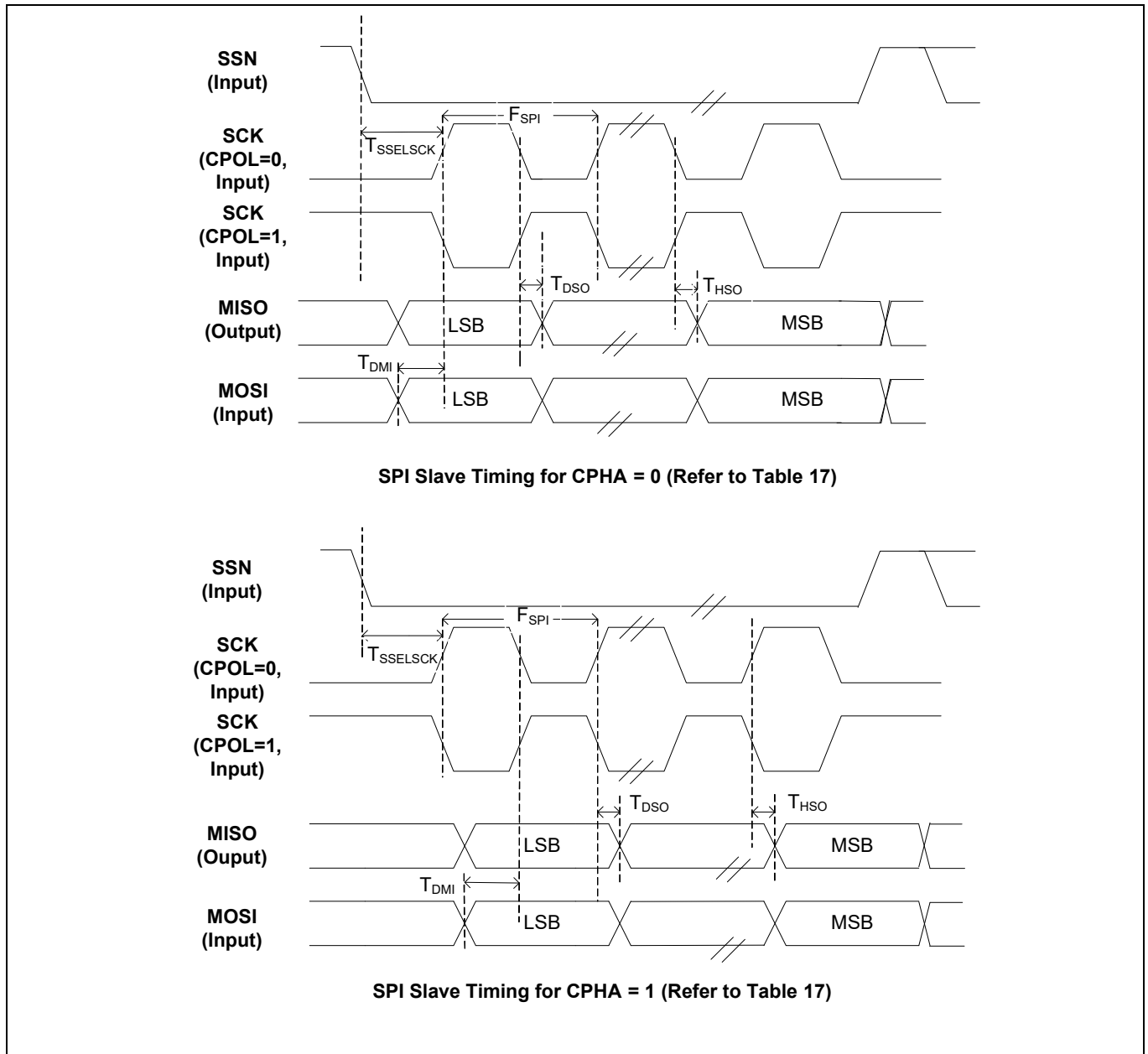

Figure 2 SPI Slave timing

Table 11 SPI AC specifications

Parameter	Description	Min	Typ	Max	Units	Details/conditions
F _{SPI}	SPI operating frequency (Master/Slave)	–	–	3	MHz	Single SCB: TX + RX Dual SCB: TX or RX
WL _{SPI}	SPI word length	4	–	16	bits	
SPI Master Mode						
T _{D_{MO}}	MOSI valid after SCl _{ock} driving edge	–	–	15	ns	
T _{D_{SI}}	MISO valid before SCl _{ock} capturing edge	20	–	–	ns	
T _{H_{MO}}	Previous MOSI data hold time with respect to capturing edge at slave	0	–	–	ns	
SPI Slave Mode						
T _{D_{MI}}	MOSI valid before Scl _{ock} Capturing edge	40	–	–	ns	
T _{D_{SO}}	MISO valid after Scl _{ock} driving edge	–	–	104.4	ns	
T _{H_{SO}}	Previous MISO data hold time	0	–	–	ns	
T _{SSEL_{SCK}}	SSEL valid to first SCK valid edge	100	–	–	ns	

Electrical specifications

3.7 I²C specifications

Table 12 I²C AC specifications

Parameter	Description	Min	Typ	Max	Units	Details/conditions
F _{I2C}	I ² C frequency	1	–	400	kHz	

3.8 JTAG specifications

Table 13 JTAG AC specifications

Parameter	Description	Min	Typ	Max	Units	Details/conditions
F _{JTAG}	JTAG operating frequency (master)	–	–	400	kHz	Code flashing

3.9 CAPSENSE™ specifications

Table 14 CAPSENSE™ AC specifications

Parameter	Description	Min	Typ	Max	Units	Details/conditions
V _{CSD}	Voltage range of operation	1.71	–	5.50	V	
SNR	Ratio of counts of finger to noise	5	–	–	Ratio	Sensor capacitance range of 9 to 35 pF; finger capacitance ≥ 0.1 pF sensitivity

3.10 Flash memory specifications

Table 15 Flash memory specifications

Parameter	Description	Min	Typ	Max	Units	Details/conditions
F _{end}	Flash endurance	100 K	–	–	cycles	
F _{ret}	Flash retention. T _A ≤ 85 °C, 10 K program/erase cycles	10	–	–	years	

Pin description

4 Pin description

Table 16 Pin description

Pin ^[3]	Type	Name		Default	Description
1	Power	VDDD		-	Supply to the device core and Interface, 1.71 to 5.5 V
2	SCB/GPIO	SCB0_0	GPIO_8	RxD_0	GPIO/SCB0. See Table 17 and Table 19 .
3	SCB/GPIO	SCB0_5	GPIO_9	DTR#_0	GPIO/SCB0. See Table 17 and Table 19 .
4	Power	VSSD		-	Digital Ground
5	SCB/GPIO	SCB1_0	GPIO_10	RxD_1	GPIO/SCB1. See Table 18 and Table 19 .
6	SCB/GPIO	SCB1_1	GPIO_11	TxD_1	GPIO/SCB1. See Table 18 and Table 19 .
7	SCB/GPIO	SCB1_2	GPIO_12	RTS#_1	GPIO/SCB1. See Table 18 and Table 19 .
8	SCB/GPIO	SCB1_3	GPIO_13	CTS#_1	GPIO/SCB1. See Table 18 and Table 19 .
9	SCB/GPIO	SCB1_4	GPIO_14	DSR#_1	GPIO/SCB1. See Table 18 and Table 19 .
10	SCB/GPIO	SCB1_5	GPIO_15	DTR#_1	GPIO/SCB1. See Table 18 and Table 19 .
11	Output	SUSPEND		-	Indicates device in suspend mode. Can be configured as active low/high using configuration utility.
12	Input	WAKEUP		-	Wakeup device from suspend mode. Can be configured as active low/high using configuration utility.
13	GPIO	GPIO_16		TRISTATE	GPIO. See Table 19 .
14	USBIO	USBDP		-	USB Data Signal Plus, integrates termination resistor and 1.5-kΩ pull up resistor
15	USBIO	USBDM		-	USB Data Signal Minus, integrates termination resistor
16	Power	VCCD		-	Regulated supply, connect to 1-μF cap or 1.8 V
17	Power	VSSD		-	Digital Ground
18	nXRES	nXRES		-	Chip reset, active low. Can be left unconnected or have a pull-up resistor connected if not used.
19	Power	VBUS		-	VBUS Supply, 3.15 V to 5.25 V
20	Power	VSSD		-	Digital Ground
21	GPIO	GPIO_17		TRISTATE	GPIO. See Table 19 .
22	GPIO	GPIO_18		TRISTATE	GPIO. See Table 19 .
23	Power	VDDD		-	Supply to the device core and Interface, 1.71 to 5.5 V
24	Power	VSSA		-	Analog Ground
25	GPIO	GPIO_0		TXLED#	GPIO. See Table 19 .
26	GPIO	GPIO_1		RXLED#	GPIO. See Table 19 .
27	SCB/GPIO	SCB0_1	GPIO_2	DSR#_0	GPIO/SCB0. See Table 17 and Table 19 .
28	SCB/GPIO	SCB0_2	GPIO_3	RTS#_0	GPIO/SCB0. See Table 17 and Table 19 .
29	SCB/GPIO	SCB0_3	GPIO_4	CTS#_0	GPIO/SCB0. See Table 17 and Table 19 .
30	SCB/GPIO	SCB0_4	GPIO_5	TxD_0	GPIO/SCB0. See Table 17 and Table 19 .
31	GPIO	GPIO_6		POWER#	GPIO. See Table 19 .
32	GPIO	GPIO_7		TRISTATE	GPIO. See Table 19 .

Pin description

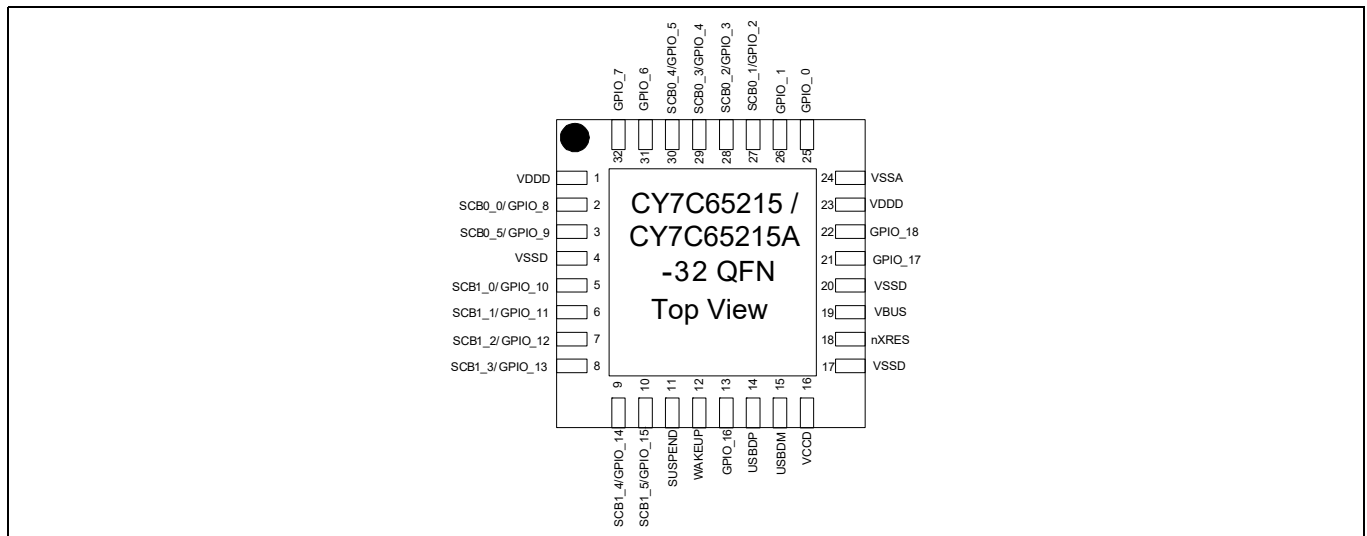

Figure 3 32-pin QFN pinout

Table 17 Serial communication block (SCB0) configuration

Pin	Serial Port 0	Mode 0*	Mode 1	Mode 2	Mode 3	Mode 4	Mode 5	Mode 6
		6-pin UART	4-pin UART	2-pin UART	SPI Master	SPI Slave	I ² C Master	I ² C Slave
2	SCB0_0	RxD_0	RxD_0	RxD_0	GPIO_8	GPIO_8	GPIO_8	GPIO_8
27	SCB0_1	DSR#_0	GPIO_2	GPIO_2	SSEL_OUT_0	SSEL_IN_0	GPIO_2	GPIO_2
28	SCB0_2	RTS#_0	RTS#_0	GPIO_3	MISO_IN_0	MISO_OUT_0	SCL_OUT_0	SCL_IN_0
29	SCB0_3	CTS#_0	CTS#_0	GPIO_4	MOSI_OUT_0	MOSI_IN_0	SDA_0	SDA_0
30	SCB0_4	TxD_0	TxD_0	TxD_0	SCLK_OUT_0	SCLK_IN_0	GPIO_5	GPIO_5
3	SCB0_5	DTR#_0	GPIO_9	GPIO_9	GPIO_9	GPIO_9	GPIO_9	GPIO_9

*Note: Device configured in Mode 0 as default. Other modes can be configured through Cypress-supplied configuration utility.

Table 18 Serial communication block (SCB1) configuration

Pin	Serial Port 1	Mode 0*	Mode 1	Mode 2	Mode 3	Mode 4	Mode 5	Mode 6	Mode 7
		6-pin UART	4-pin UART	2-pin UART	SPI Master	SPI Slave	I ² C Master	I ² C Slave	JTAG Master
5	SCB1_0	RxD_1	RxD_1	RxD_1	MISO_IN_1	MISO_OUT_1	SCL_OUT_1	SCL_IN_1	TDO
6	SCB1_1	TxD_1	TxD_1	TxD_1	MOSI_OUT_1	MOSI_IN_1	SDA_1	SDA_1	TDI
7	SCB1_2	RTS#_1	RTS#_1	GPIO_12	SSEL_OUT_1	SSEL_IN_1	GPIO_12	GPIO_12	TMS
8	SCB1_3	CTS#_1	CTS#_1	GPIO_13	SCLK_OUT_1	SCLK_IN_1	GPIO_13	GPIO_13	TCK
9	SCB1_4	DSR#_1	GPIO_14	GPIO_14	GPIO_14	GPIO_14	GPIO_14	GPIO_14	TRST#

Note

3. Any pin acting as an Input pin should not be left unconnected.

Pin description

Table 18 Serial communication block (SCB1) configuration

Pin	Serial Port 1	Mode 0*	Mode 1	Mode 2	Mode 3	Mode 4	Mode 5	Mode 6	Mode 7
		6-pin UART	4-pin UART	2-pin UART	SPI Master	SPI Slave	I ² C Master	I ² C Slave	JTAG Master
10	SCB1_5	DTR#_1	GPIO_15	GPIO_15	GPIO_15	GPIO_15	GPIO_15	GPIO_15	GPIO_15

*Note: Device configured in Mode 0 as default. Other modes can be configured via Cypress-supplied configuration utility.

Pin description

	GPIO
	SCB0
	SCB1

Pin description

Table 19 GPIO configuration

GPIO configuration option	Description
TRISTATE	I/O tristated
DRIVE 1	Output static 1
DRIVE 0	Output static 0
POWER#	This output is used to control power to an external logic via switch to cut power off during unconfigured USB device and USB suspend. 0 - USB device in Configured state 1 - USB device in Unconfigured state or during USB suspend mode
TXLED#	Drives LED during USB transmit
RXLED#	Drives LED during USB receive
TX or RX LED#	Drives LED during USB transmit or receive
BCD0 BCD1	Configurable battery charger detect pins to indicate type of USB charger (SDP, CDP, or DCP) Configuration example: 00 - Draw up to 100 mA (Unconfigured state) 01 - SDP (up to 500 mA) 10 - CDP/DCP (up to 1.5 A) 11 - Suspend (up to 2.5 mA) This truth table can be configured using the configuration utility
BUSDETECT	VBUS detection. Connect VBUS to this pin via resistor network for VBUS detection when using BCD feature (refer to page 20).
CS0, CS1, CS2, CS3, CS4, CS5, CS6, CS7	CAPSENSE™ button input (Max up to 8)
CSout0, CSout1, CSout2, CSout3	Indicates which CAPSENSE™ button is pressed
Cmod (Available on GPIO_0 only)	External modulator capacitor, connect a 2.2 nF capacitor (±10%) to ground
Cshield (optional)	Shield for waterproofing

Note: These signal options can be configured on any of the available GPIO pins using Cypress-supplied configuration utility.

5 USB power configurations

The following section describes possible USB power configurations for the CY7C65215/CY7C65215A. Refer to the “Pin description” on page 24 for signal details.

5.1 USB bus-powered configuration

Figure 4 shows an example of the CY7C65215/CY7C65215A in a bus-powered design. VBUS is connected directly to the CY7C65215/CY7C65215A because it has an internal regulator.

The USB bus-powered system must comply with the following requirements:

1. The system should not draw more than 100 mA prior to USB enumeration (Unconfigured state).
2. The system should not draw more than 2.5 mA during USB Suspend mode.
3. A high-power bus-powered system (can draw more than 100 mA when operational) must use POWER# (configured over GPIO) to keep the current consumption below 100 mA prior to USB enumeration, and 2.5 mA during USB Suspend state.
4. The system should not draw more than 500 mA from the USB host.

The configuration descriptor in the CY7C65215/CY7C65215A flash should be updated to indicate bus power and the maximum current required by the system using the configuration utility.

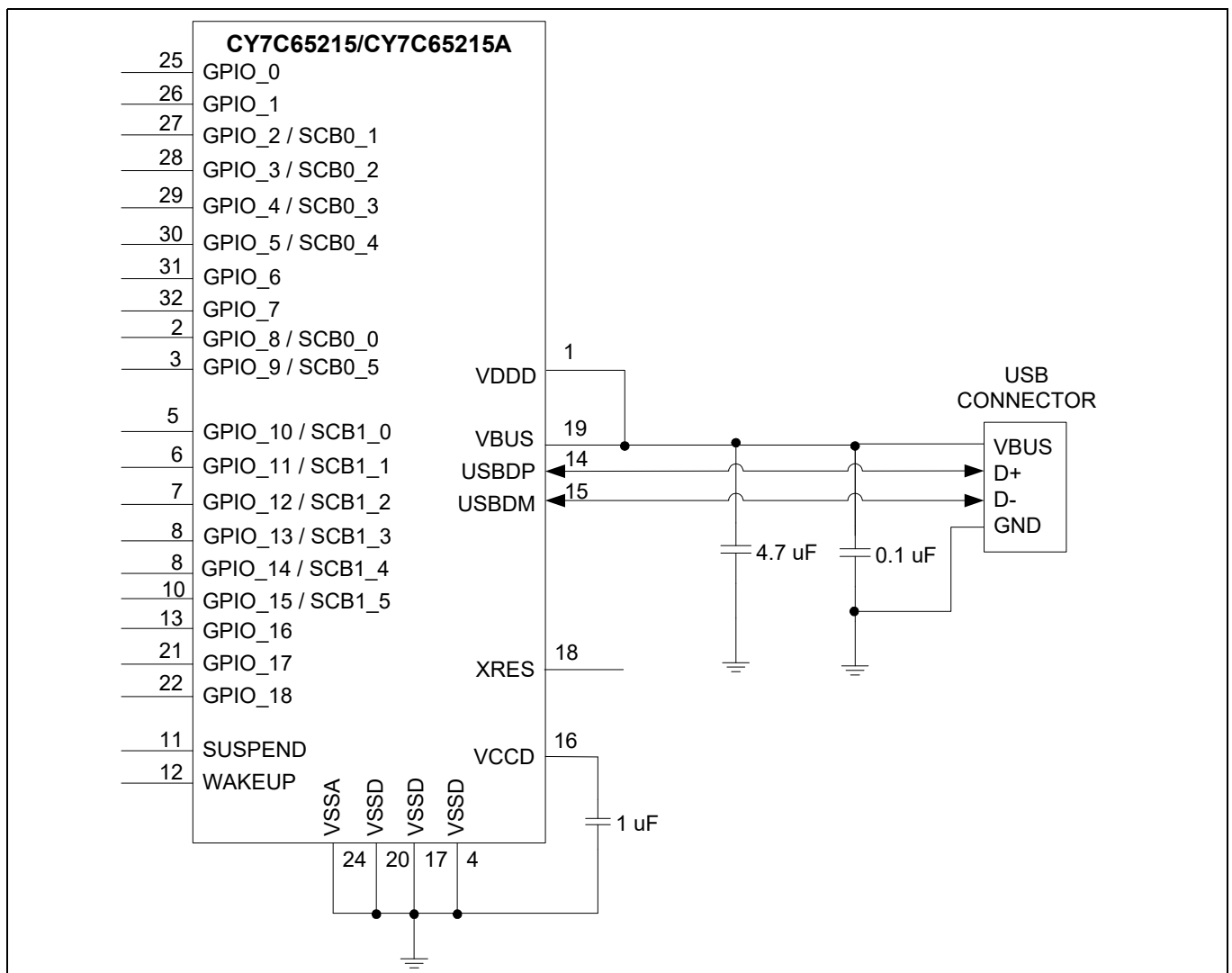

Figure 4 Bus-powered configuration

5.2 Self-powered configuration

Figure 5 shows an example of CY7C65215/CY7C65215A in a self-powered design.

In this configuration:

- VBUS is powered from USB VBUS. VBUS pin is also used to detect USB connection.
- VDDD is powered from an external power supply.

When VBUS is present, CY7C65215/CY7C65215A enables an internal, 1.5-kΩ pull-up resistor on USBDP. When VBUS is absent (USB host is powered down), CY7C65215/CY7C65215A removes the 1.5-kΩ pull-up resistor on USBDP, and this ensures no current flows from the USBDP to the USB host via a 1.5-kΩ pull-up resistor, to comply with USB 2.0 specification.

When reset is asserted to CY7C65215, all the I/O pins are tristated.

Using the configuration utility, the configuration descriptor in the CY7C65215/CY7C65215A flash should be updated to indicate that it is self-powered.

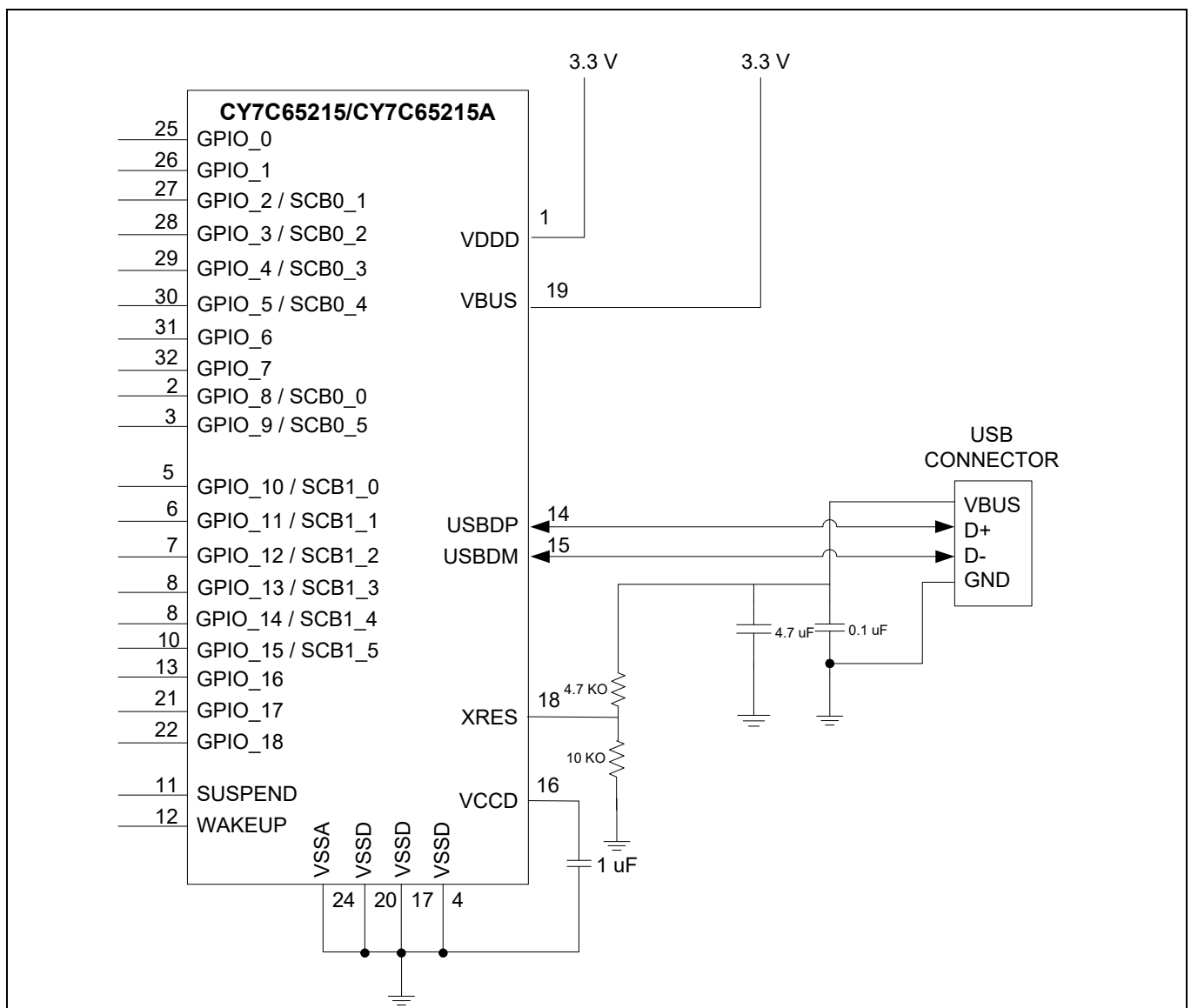

Figure 5 Self-powered configuration

5.3 USB bus powered with variable I/O voltage

Figure 6 shows CY7C65215/CY7C65215A in a bus-powered system with variable I/O voltage. A low dropout (LDO) regulator is used to supply 1.8 V or 3.3 V (using a jumper switch) the input of which is 5 V from VBUS. Another jumper switch is used to select 1.8/3.3 V or 5 V from VBUS for the VDDD pin of CY7C65215/CY7C65215A. This allows I/O voltage and supply to external logic to be selected among 1.8 V, 3.3 V, or 5 V.

The USB bus-powered system must comply with the following:

- The system should not draw more than 100 mA prior to USB enumeration (Unconfigured state).
- The system should not draw more than 2.5 mA during USB Suspend mode.
- A high-power bus-powered system (can draw more than 100 mA when operational) must use POWER# (configured over GPIO) to keep the current consumption below 100 mA prior to USB enumeration and 2.5 mA during USB Suspend state.

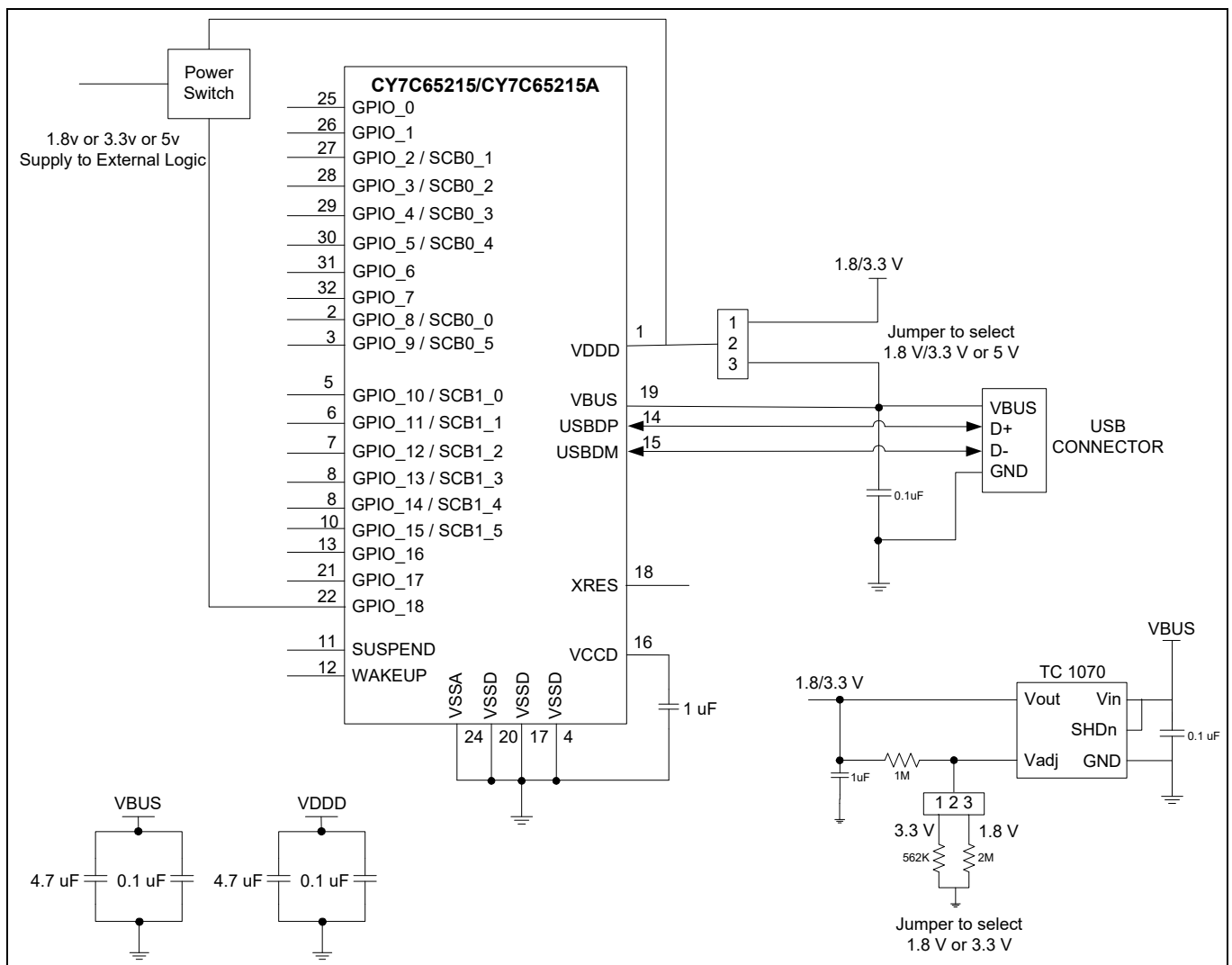

Figure 6 USB bus-powered with 1.8 V, 3.3 V, or 5 V variable I/O voltage ^[4]

Note

1. $1.71\text{ V} \leq V_{DDD} \leq 1.89\text{ V}$ - Short VCCD pin with VDDD pin; $V_{DDD} > 2\text{ V}$ - connect a 1- μF decoupling capacitor to the VCCD pin.

6 Application examples

The following section provides CY7C65215/CY7C65215A application examples.

6.1 USB-to-dual UART bridge with battery-charge detection

CY7C65215/CY7C65215A can connect any embedded system, with a serial port, to a host PC through USB. CY7C65215/CY7C65215A enumerates as a dual COM port on the host PC.

SUSPEND is connected to the MCU to indicate USB suspend or USB Unconfigured and the WAKEUP pin is used to wake up CY7C65215/CY7C65215A, which in turn issues a remote wakeup to the USB host. GPIO1 and GPIO0 are configured as RXLED# and TXLED# to drive two LEDs indicating data receive and transmit respectively.

CY7C65215/CY7C65215A implements the battery charger detection functionality based on the USB Battery Charging Specification Rev 1.2.

Battery-operated bus power systems must comply with the following conditions:

- The system can be powered from the battery (if not discharged) and be operational if VBUS is not connected or powered down.
- The system should not draw more than 100 mA from the VBUS prior to USB enumeration and USB Suspend mode.
- The system should not draw more than 500 mA for SDP and 1.5 A for CDP/DCP

To comply with the first requirement, VBUS from the USB host is connected to the battery charger as well as CY7C65215/CY7C65215A as shown in [Figure 7](#). When VBUS is connected, CY7C65215/CY7C65215A initiates battery charger detection and indicates the type of USB charger over BCD0 and BCD1. If the USB charger is SDP or CDP, CY7C65215/CY7C65215A enables a 1.5-K pull-up resistor on the USBDP for Full-Speed enumeration. When VBUS is disconnected CY7C65215/CY7C65215A indicates absence of the USB charger over BCD0 and BCD1, and removes the 1.5-K pull-up resistor on USBDP. Removing this resistor ensures no current flows from the supply to the USB host through the USBDP, to comply with the USB 2.0 specification.

To comply with the second and third requirements, two signals (BCD0 and BCD1) are configured over GPIO to communicate the type of USB host charger and the amount of current it can draw from the battery charger. The BCD0 and BCD1 signals can be configured using the configuration utility.

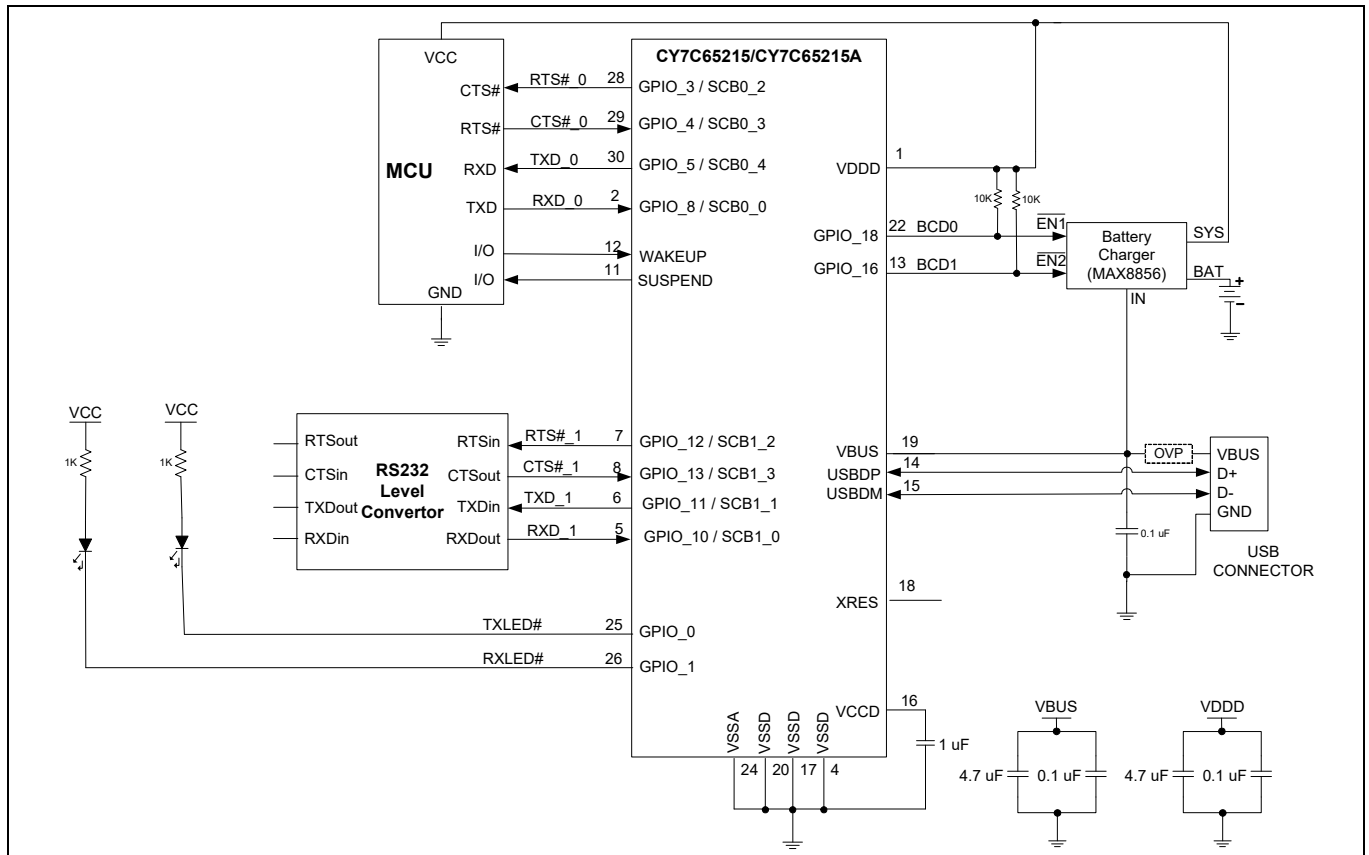

Figure 7 USB to dual UART bridge with battery charge detection^[5]

Note

5. Add a 100 K pull-down resistor on the V_{BUS} pin for quick discharge.

Application examples

In a battery charger system, a 9-V spike on the VBUS is possible. The CY7C65215/CY7C65215A VBUS pin is intolerant to voltage above 6 V. In the absence of over-voltage protection (OVP) on the VBUS line, VBUS should be connected to BUSDETECT (GPIO configured) using the resistive network and the output of battery charger to the VBUS pin of CY7C65215/CY7C65215A, as shown in the following figure.

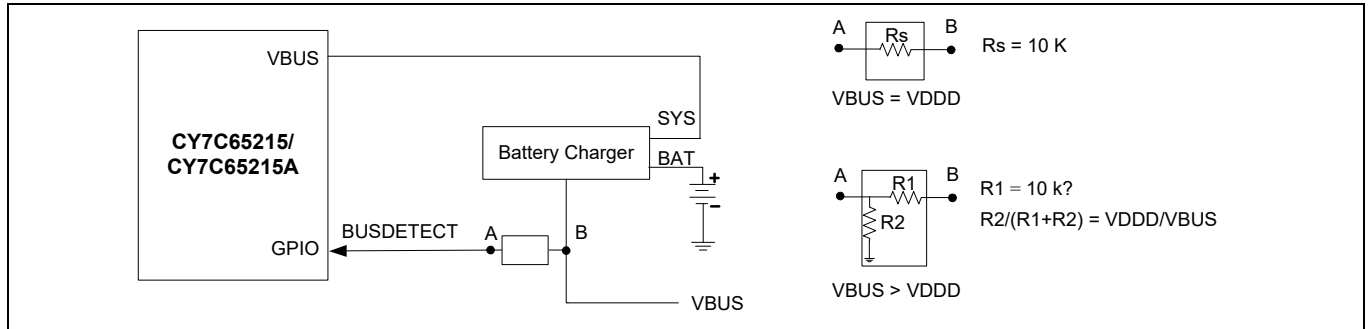

When VBUS and VDDD are at the same voltage potential, VBUS can be connected to GPIO using a series resistor (R_s). This is shown in **Figure 8**. If there is a charger failure and VBUS becomes 9 V, then the 10-k Ω resistor plays two roles. It reduces the amount of current flowing into the forward biased diodes in the GPIO, and it reduces the voltage seen on the pad.

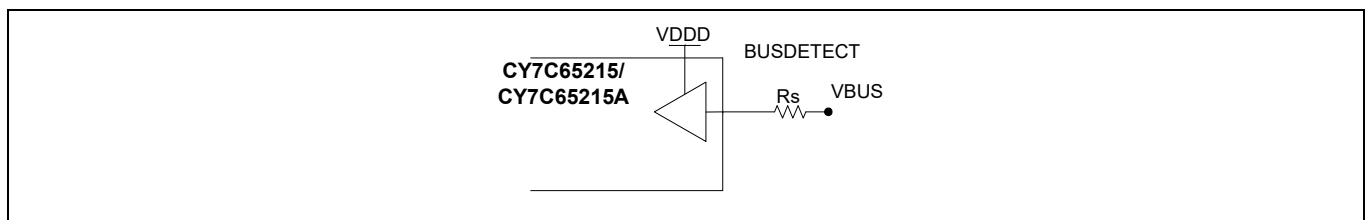

Figure 8 GPIO VBUS detection, VBUS = VDDD

When VBUS > VDDD, a resistor voltage divider is necessary to reduce the voltage from VBUS down to VDDD for the GPIO sensing the VBUS voltage. This is shown in the following figure. The resistors should be sized as follows:

$$R_1 \geq 10 \text{ K}$$

$$R_2 / (R_1 + R_2) = V_{DDD} / V_{BUS}$$

The first condition limits the voltage and current for the charger failure situation, as described in the previous paragraph, while the second condition allows for normal-operation VBUS detection.

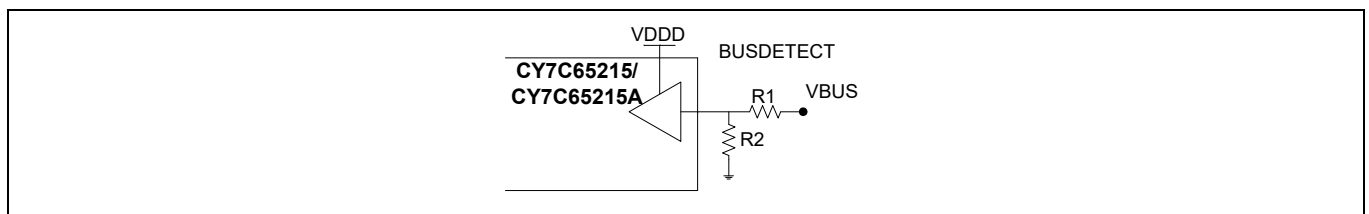

Figure 9 GPIO VBUS detection, VBUS > VDDD

6.2 USB to RS485 application

CY7C65215 can be configured as dual USB to UART interface. This UART interface operates at TTL level and it can be converted to RS485 interface using a GPIO and any half duplex RS485 transceiver IC (to convert TTL level to RS485 level) as shown in following figure. This GPIO (TXD Enable) enables and disables the RS485 transceiver IC based on availability of character in UART buffer of CY7C65215A. This GPIO can be configured using USB-Serial Configuration utility. **Figure 11** shows timing diagram of this GPIO.

RS485 is a multi-drop network – that is, many devices can communicate with each other over a single two-wire cable connection. The RS485 cable requires to be terminated at each end of the cable. Links are provided to allow the cable to be terminated if the device is physically positioned at either end of the cable.

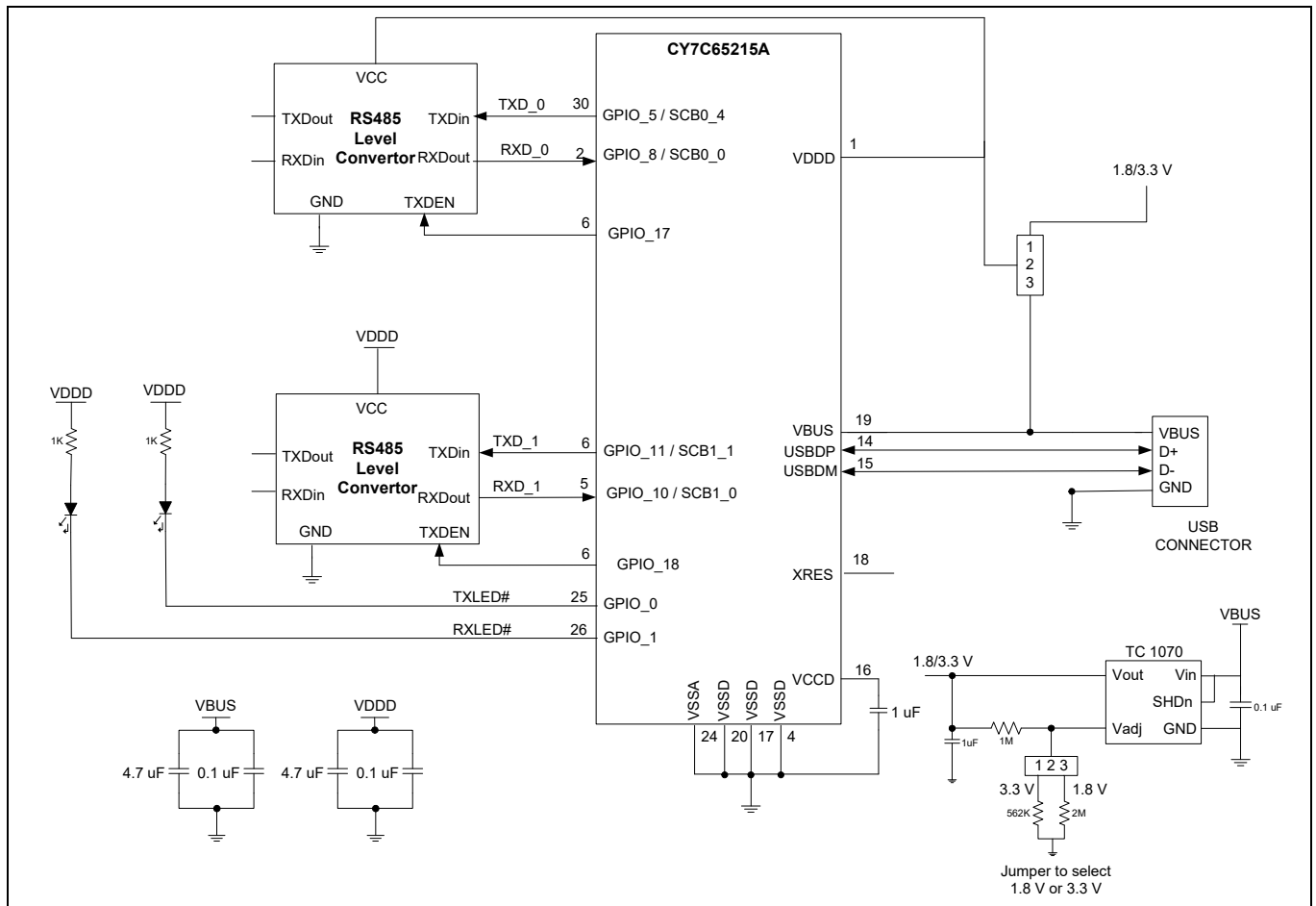

Figure 10 USB-to-RS485 bridge

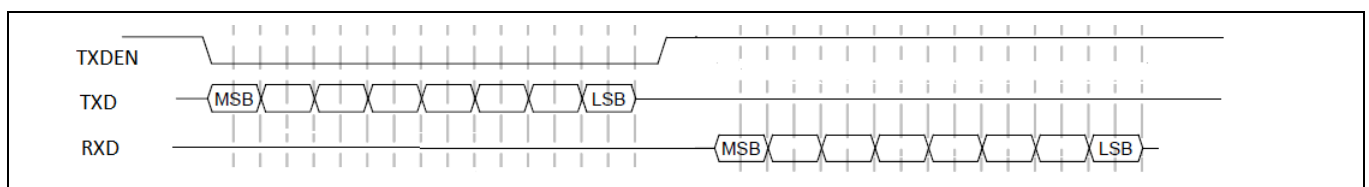

Figure 11 RS485 GPIO (TXDEN) timing diagram

6.3 CAPSENSE™

In **Figure 12** CY7C65215/CY7C65215A is configured to support six CAPSENSE™ buttons. Three GPIOs (CSout0, CSout1, and CSout2) are configured to indicate which CAPSENSE™ button is pressed by the finger. It also implements a 2-pin UART on SCB0 and a 4-pin UART on SCB1.

A 2.2-nF (10%) capacitor (Cmod) must be connected on the GPIO_0 pin for proper CAPSENSE™ operation. Optionally, the GPIO_7 pin is configured as Cshield and connected to the shield of the CAPSENSE™ (pin 2 of Watershield jumper) as shown in **Figure 12**. The shield prevents false triggering of buttons due to water droplets and guarantees CAPSENSE™ operation (sensors respond to finger touch).

For further information on CAPSENSE™, refer to **Getting Started with CAPSENSE™**.

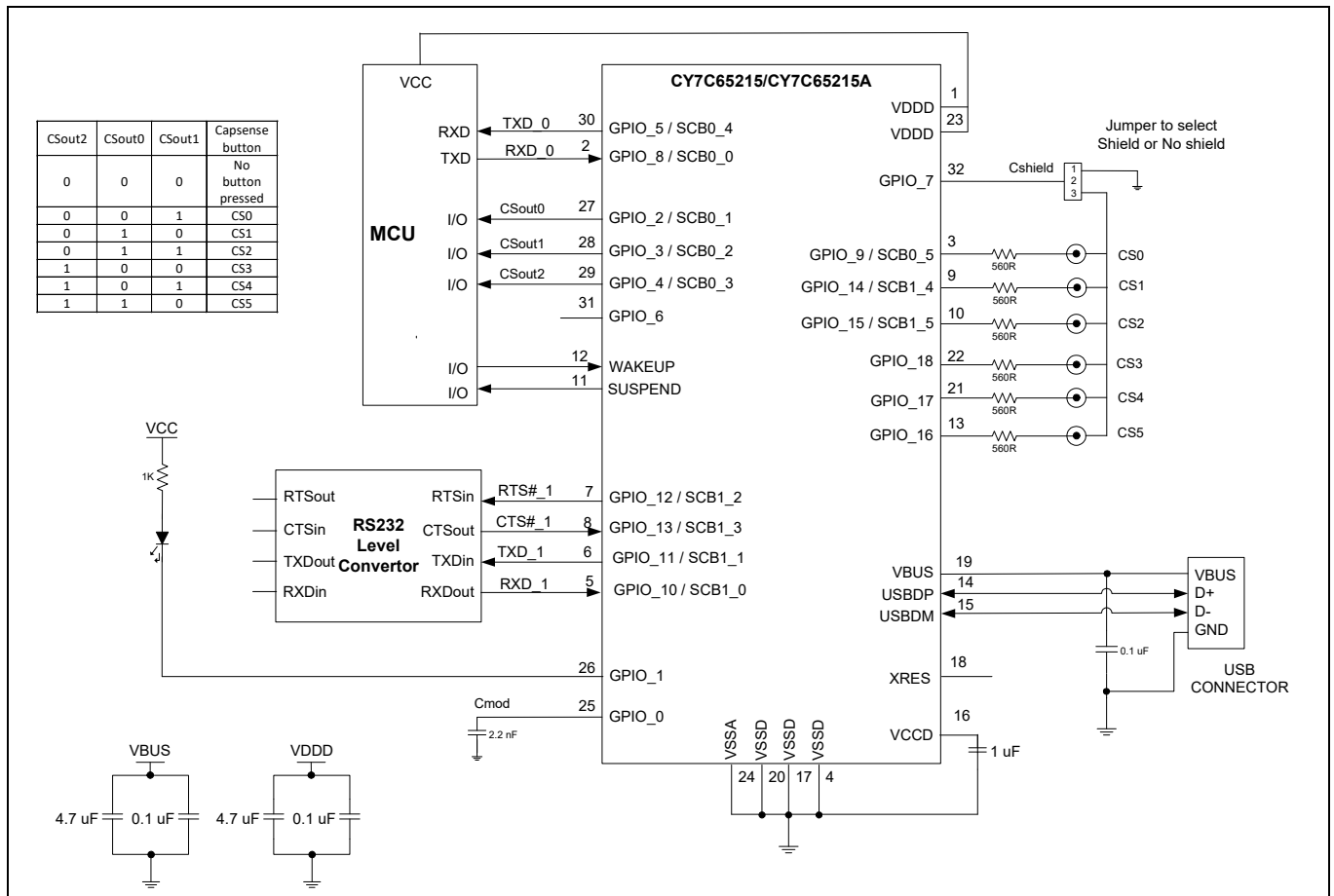

Figure 12 CAPSENSE™ schematic

6.4 USB to dual channel (I²C/SPI) bridge

In **Figure 13**, CY7C65215/CY7C65215A is configured as a USB-to-Dual Channel (I²C/SPI) Bridge. GPIO1 and GPIO0 are configured as RXLED# and TXLED# to drive two LEDs indicating data USB receive and transmit respectively.

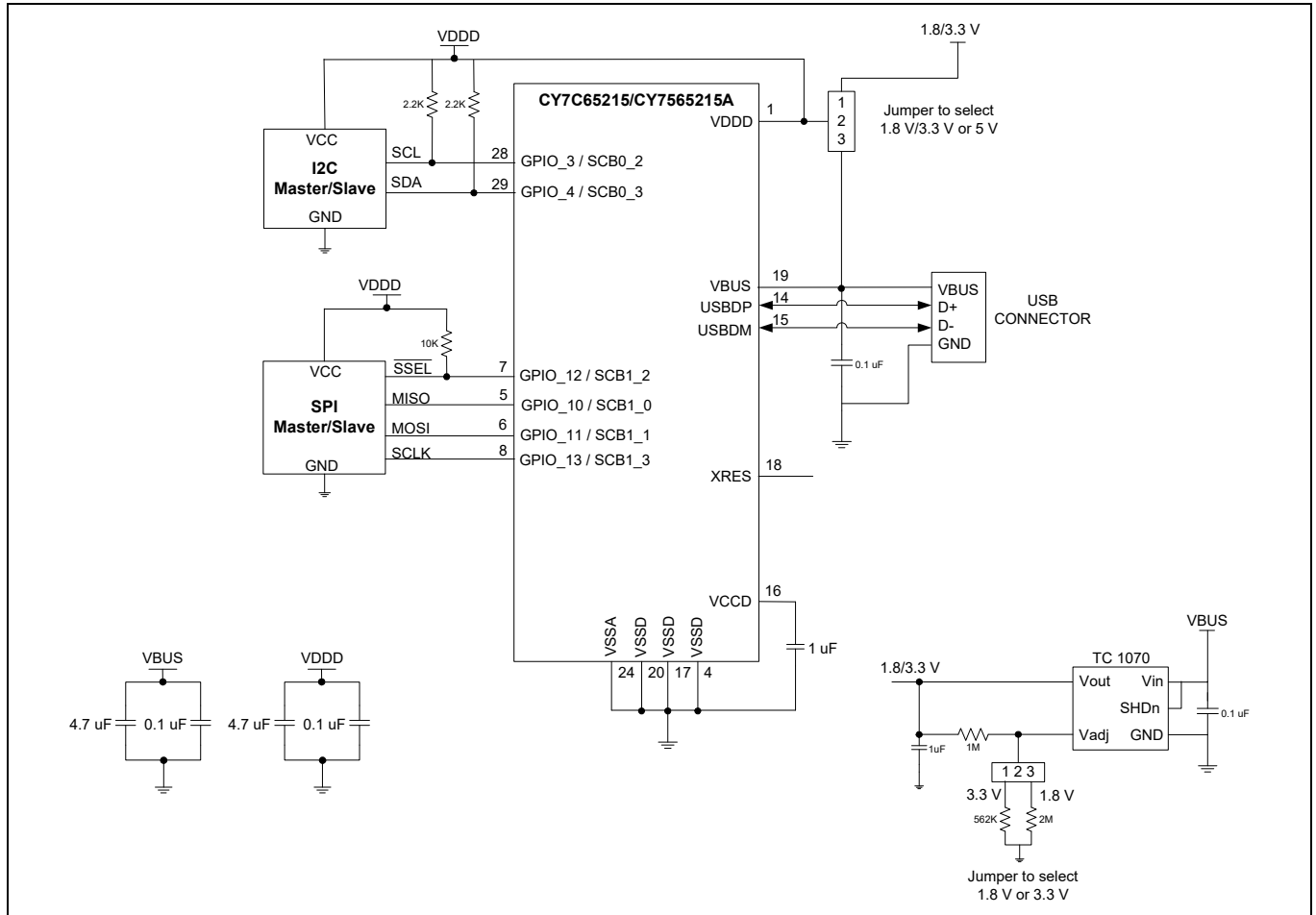

Figure 13 USB-to-I²C/SPI bridge

Application examples

I²C

The CY7C65215/CY7C65215A I²C can be configured as a Master or Slave using the configuration utility. CY7C65215/CY7C65215A supports I²C data rates up to 100 kbps in the standard mode (SM) and 400 kbps in the fast mode (FM).

In the master mode, SCL is output from CY7C65215/CY7C65215A. In the slave mode, SCL is input to CY7C65215/CY7C65215A. The I²C slave address for CY7C65215/CY7C65215A can be configured using the configuration utility. The SDA data line is bi-directional in the master and slave modes. The drive modes of the SCL and SDA port pins are always open drain.

Refer to the NXP I²C specification for further details on protocol.

SPI

The CY7C65215/CY7C65215A SPI can be configured as a Master or Slave using the configuration utility. CY7C65215/CY7C65215A supports SPI master frequency up to 3 MHz and SPI slave frequency up to 1 MHz. It can support transaction sizes ranging from 4 bits to 16 bits, which can be configured using the configuration utility.

In the master mode, SCLK, MOSI and SSEL lines act as output and MISO acts as an input. In the slave mode, SCLK, MOSI, and SSEL lines act as input and MISO acts as an output.

CY7C65215/CY7C65215A supports three versions of the SPI protocol:

- Motorola - This is the original SPI protocol.
- Texas Instruments - A variation of the original SPI protocol in which data frames are identified by a pulse on the SSEL line.
- National Semiconductors - A half-duplex variation of the original SPI protocol.

Application examples

Motorola

The original SPI protocol is defined by Motorola. It is a full-duplex protocol: transmission and reception occur at the same time.

A single (full-duplex) data transfer follows these steps: The master selects a slave by driving its SSEL line to '0'. Next, it drives data on its MOSI line and it drives a clock on its SCLK line. The slave uses the edges of the transmitted clock to capture the data on the MOSI line. The slave drives data on its MISO line. The master captures the data on the MISO line. The process is repeated for all the bits in the data transfer.

Multiple data transfers may happen without the SSEL line changing from '0' to '1' and back from '1' to '0' in between the individual transfers. As a result, slaves must keep track of the progress of data transfers to separate individual transfers.

When not transmitting data, the SSEL line is '1' and SCLK is typically off.

The Motorola SPI protocol has four different modes that determine how data is driven and captured on the MOSI and MISO lines. These modes are determined by clock polarity (CPOL) and clock phase (CPHA). Clock polarity determines the value of the SCLK line when not transmitting data:

- CPOL is '0': SCLK is '0' when not transmitting data.
- CPOL is '1': SCLK is '1' when not transmitting data.

Clock phase determines when data is driven and captured. It is dependent on the value of CPOL:

Table 20 SPI protocol modes

Mode	CPOL	CPHA	Description
0	0	0	Data is driven on a falling edge of SCLK. Data is captured on a rising edge of SCLK.
1	0	1	Data is driven on a rising edge of SCLK. Data is captured on a falling edge of SCLK.
2	1	0	Data is driven on a rising edge of SCLK. Data is captured on a falling edge of SCLK.
3	1	1	Data is driven on a falling edge of SCLK. Data is captured on a rising edge of SCLK.

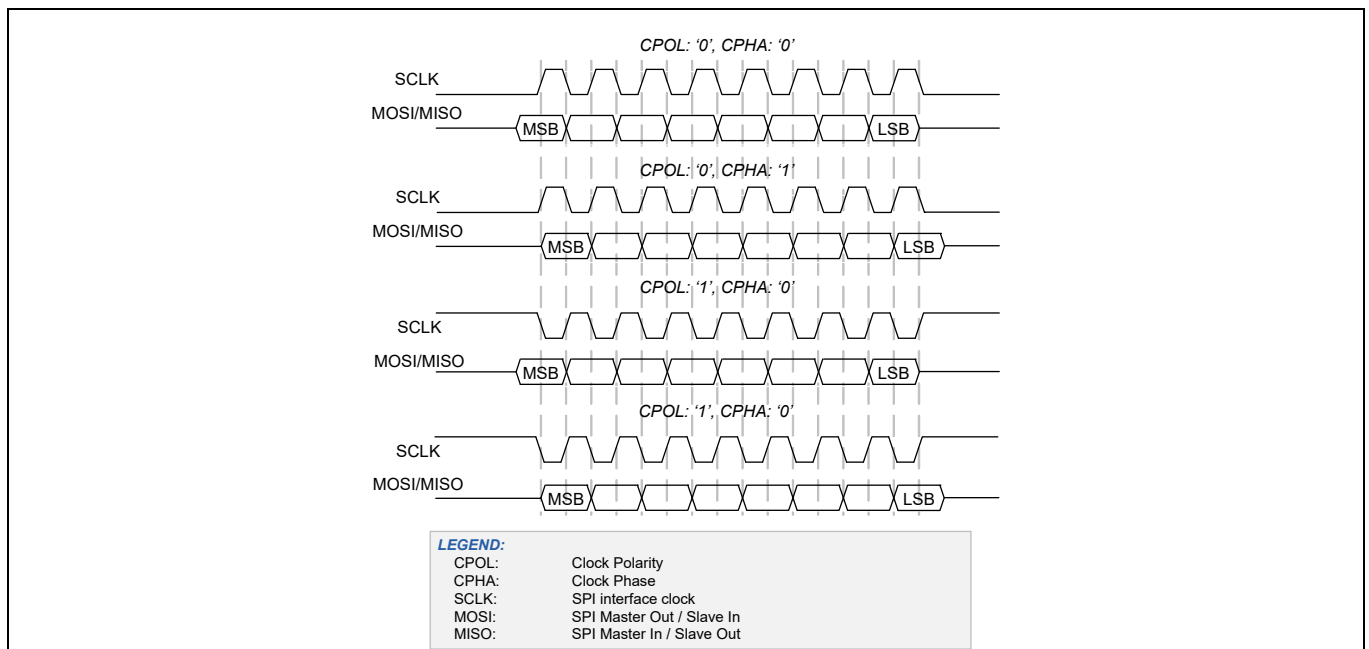

Figure 14 Driving and capturing of MOSI/MISO Data as a function of CPOL and CPHA

Application examples

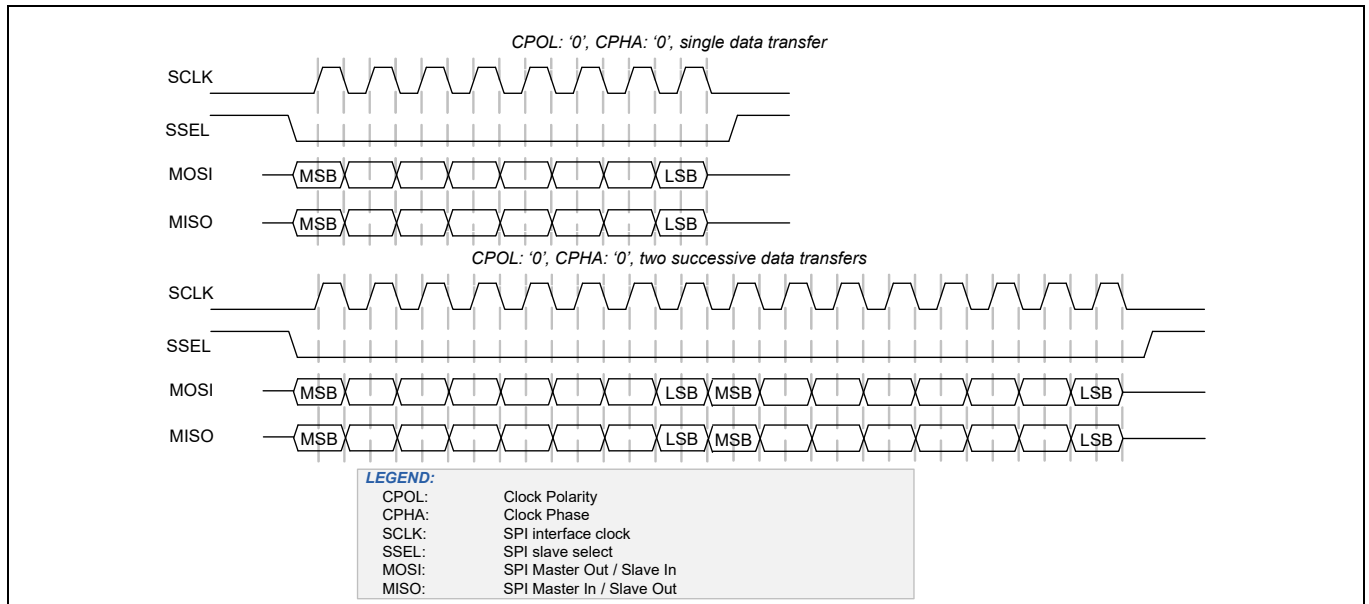

Figure 15 Single 8-bit data transfer and two successive 8-bit data transfers in mode 0 (CPOL is '0', CPHA is '0')

Application examples

Texas Instruments

The Texas Instruments' SPI protocol redefines the use of the SSEL signal. It uses the signal to indicate the start of a data transfer, rather than a low, active slave-select signal. The start of a transfer is indicated by a high, active pulse of a single-bit transfer period. This pulse may occur one cycle before the transmission of the first data bit, or may coincide with the transmission of the first data bit. The transmitted clock SCLK is a free-running clock.

The TI SPI protocol only supports mode 1 (CPOL is '0' and CPHA is '1'): data is driven on a rising edge of SCLK and data is captured on a falling edge of SCLK.

The following figure illustrates a single 8-bit data transfer and two successive 8-bit data transfers. The SSEL pulse precedes the first data bit. Note how the SSEL pulse of the second data transfer coincides with the last data bit of the first data transfer.

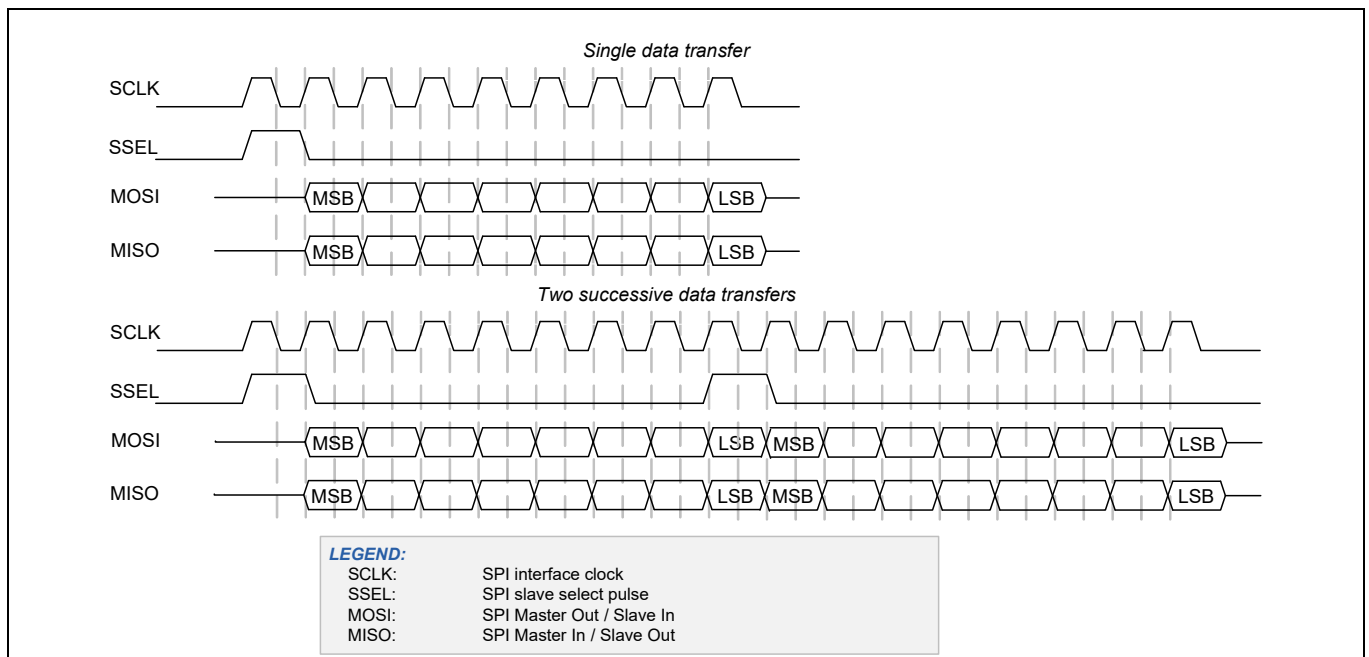

The following figure illustrates a single 8-bit data transfer and two successive 8-bit data transfers. The SSEL pulse coincides with the first data bit.

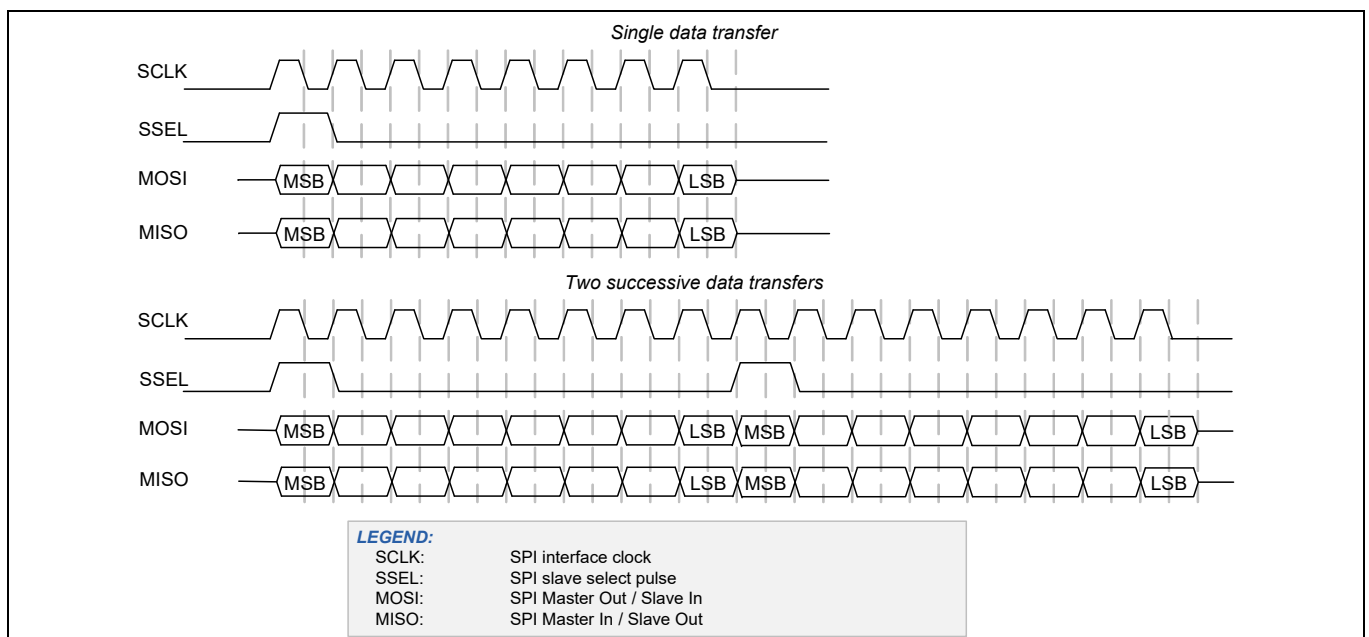

Application examples

National Semiconductors

The National Semiconductors' SPI protocol is a half-duplex protocol. Rather than transmission and reception occurring at the same time, transmission and reception take turns (transmission happens before reception). A single "idle" bit transfer period separates transmission from reception.

Note: Successive data transfers are NOT separated by an "idle" bit transfer period.

The transmission data transfer size and reception data transfer size may differ. The National Semiconductors' SPI protocol only supports mode 0: data is driven on a falling edge of SCLK and data is captured on a rising edge of SCLK.

The following figure illustrates a single data transfer and two successive data transfers. In both cases, the transmission data transfer size is 8 bits and the reception transfer size is 4 bits.

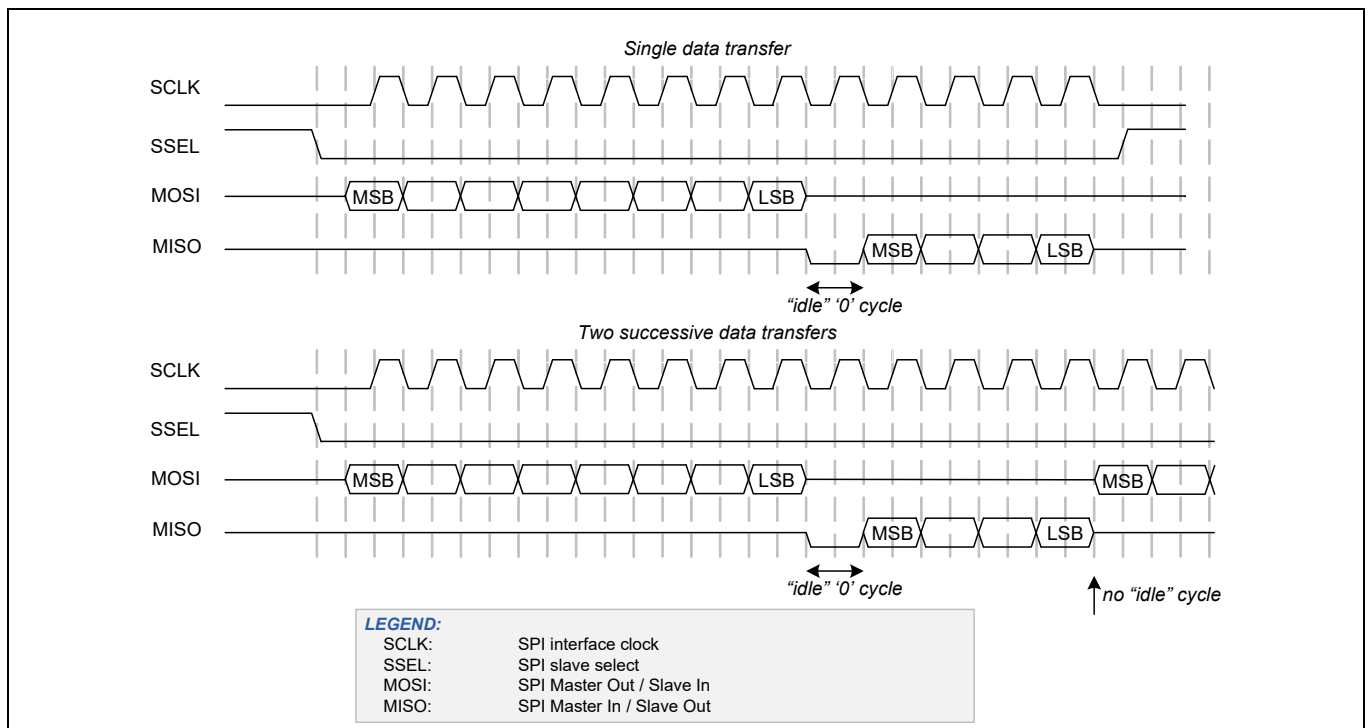

The above figure defines MISO and MOSI as undefined when the lines are considered idle (not carrying valid information). It will drive the outgoing line values to '0' during idle time (to satisfy the requirements of specific master devices (NXP LPC17xx) and specific slave devices (MicroChip EEPROM)).

Ordering information

7 Ordering information

Table 21 lists the CY7C65215/CY7C65215A key package features and ordering codes. For more information, contact your local sales representative.

Table 21 Key features and ordering information

Package	Ordering code	Operating range
32-pin QFN (5 × 5 × 1 mm, 0.5 mm pitch) (Pb-free)	CY7C65215-32LTXI	Industrial
32-pin QFN (5 × 5 × 1 mm, 0.5 mm pitch) (Pb-free) – Tape and Reel	CY7C65215-32LTXIT	Industrial
32-pin QFN (5 × 5 × 1 mm, 0.5 mm pitch) (Pb-free)	CY7C65215A-32LTXI	Industrial
32-pin QFN (5 × 5 × 1 mm, 0.5 mm pitch) (Pb-free) – Tape and Reel	CY7C65215A-32LTXIT	Industrial

7.1 Ordering code definitions

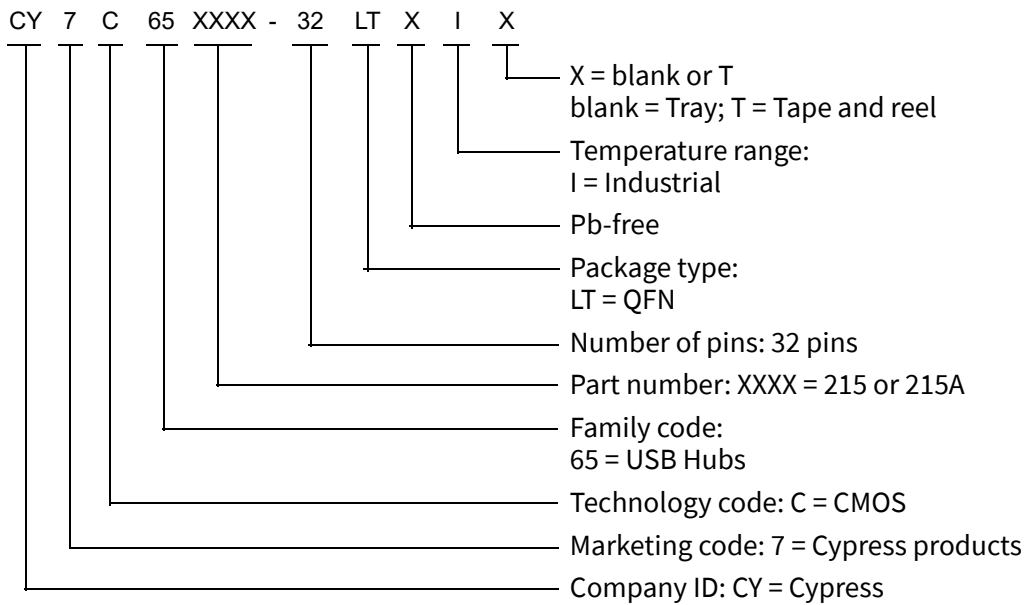

8 Package information

The package currently planned to be supported is the 32-pin QFN.

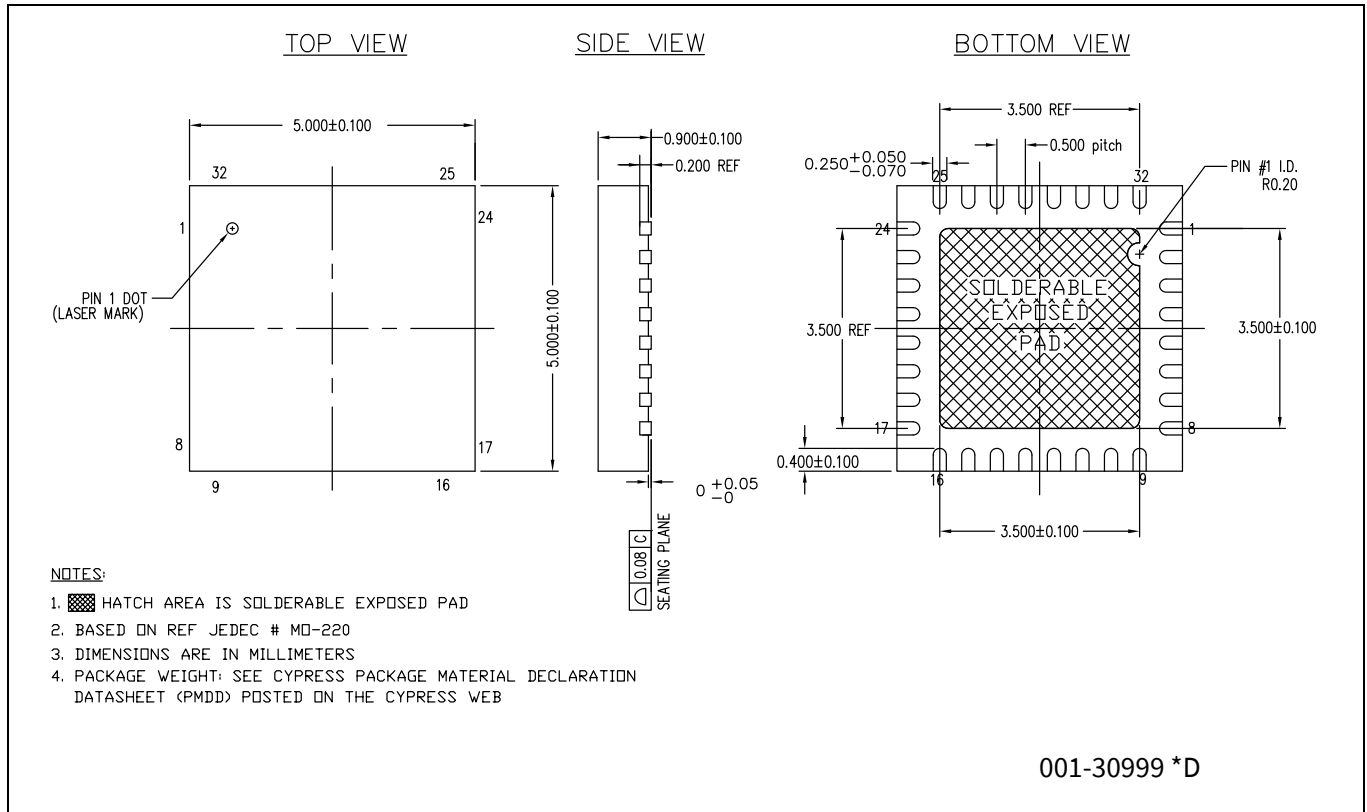

Figure 16 32-pin QFN (5 × 5 × 1.0 mm (3.5 × 3.5 E-Pad (Sawn))) package outline, 001-30999

Table 22 Package characteristics

Parameter	Description	Min	Typ	Max	Units
T _A	Operating ambient temperature	-40	25	85	°C
THJ	Package θ _{JA}	-	19	-	°C/W

Table 23 Solder reflow peak temperature

Package	Maximum Peak Temperature	Maximum Time at Peak Temperature
32-pin QFN	260°C	30 seconds

Table 24 Package moisture sensitivity level (MSL), IPC/JEDEC J-STD-2

Package	MSL
32-pin QFN	MSL 3

9 Acronyms

Table 25 Acronyms used in this document

Acronym	Description
BCD	battery charger detection
CDC	communication driver class
CDP	charging downstream port
DCP	dedicated charging port
DLL	dynamic link library
ESD	electrostatic discharge
GPIO	general purpose input/output
HBM	human-body model
I ² C	inter-integrated circuit
MCU	Microcontroller Unit
OSC	oscillator
PHDC	personal health care device class
PID	Product Identification
SCB	serial communication block
SCL	I2C Serial Clock
SDA	I2C Serial Data
SDP	Standard Downstream Port
SIE	serial interface engine
SPI	serial peripheral interface
VCOM	virtual communication port
USB	Universal Serial Bus
UART	universal asynchronous receiver transmitter
VID	Vendor Identification

10 Document conventions

10.1 Units of measure

Table 26 Units of Measure

Symbol	Unit of measure
°C	degree Celsius
DMIPS	dhrystone million instructions per second
kΩ	kilo-ohm
KB	kilobyte
kHz	kilohertz
kV	kilovolt
Mbps	megabits per second
MHz	megahertz
mm	millimeter
V	volt

11 Errata

This section describes the errata for the CY7C65215/CY7C65215A USB-Serial family. Details include errata trigger conditions, scope of impact, and available workaround.

Contact your local Cypress Sales Representative if you have questions.

Part numbers affected

Part number	Device characteristics
CY7C65215	All Variants
CY7C65215A	All Variants

Qualification status

Production

Errata summary

The following table defines the errata applicability to available USB-Serial devices.

Items	Affected part number	Fix status
[1] The measured I2C Master clock (SCL) frequency is different from the configured clock frequency.	CY7C65215	Fixed in CY7C65215A
[2] Data loss during SPI communication at data rate of 3 Mbps.	CY7C65215	Fixed in CY7C65215A
[3] USB-Serial as I2C Master reads one extra byte of data than requested by the USB Host.	CY7C65215	Fixed in CY7C65215A
[4] JTAG on SCB1 cannot simultaneously operate with I2C/SPI/UART on SCB0.	CY7C65215 CY7C65215A	No Fix
[5] I2C Reads are slower when USB-Serial is configured as I2C Master.	CY7C65215 CY7C65215A	Workaround Provided
[6] USB-Serial does not report UART Frame Errors.	CY7C65215 CY7C65215A	No Fix
[7] USB-Serial does not report MARK or SPACE Parity errors.	CY7C65215 CY7C65215A	No Fix

1. The measured I ² C Master clock (SCL) frequency is different from the configured clock frequency.	
Problem Definition	The measured I ² C clock frequency is 20 percent less than the configured SCL frequency
Parameters Affected	NA
Trigger Condition(s)	NA
Scope of Impact	I ² C read and write operations will be slower than the configured rate
Workaround	No workaround
Fix Status	Fixed in CY7C65215A

2. Data loss during SPI communication at data rate of 3 Mbps.	
Problem Definition	Data loss is observed when using SPI at data rate of 3 Mbps
Parameters Affected	NA
Trigger Condition(s)	Data rate of 3 Mbps triggers the data loss during SPI communication
Scope of Impact	Data loss will be observed at 3 Mbps during SPI communication
Workaround	No workaround
Fix Status	Fixed in CY7C65215A

3. USB-Serial as I²C Master reads one extra byte of data than requested by the USB Host.	
Problem Definition	USB-Serial configured as an I ² C Master reads an extra byte of data than requested from an I ² C Slave. However, only the requested number of bytes are returned to the USB host
Parameters Affected	NA
Trigger Condition(s)	No specific trigger condition. An extra byte of data is read from the slave by the master on every I ² C read
Scope of Impact	I ² C slave may enter an unrecoverable state and hold the SCL line indefinitely, eventually resulting in data loss
Workaround	No workaround
Fix Status	Fixed in CY7C65215A

4. JTAG on SCB1 cannot simultaneously operate with I²C/SPI/UART on SCB0.	
Problem Definition	SCB0 stops functioning when SCB1 configured as JTAG is in operation
Parameters Affected	NA
Trigger Condition(s)	Simultaneous operation of JTAG on SCB1 and I ² C/SPI/UART on SCB0 causes SCB0 to stop functioning
Scope of Impact	JTAG cannot be simultaneously used along with I ² C/SPI/UART on SCB0. There will not be any functional impact while using JTAG and I ² C/SPI/UART on SCB0 if both are not operated simultaneously.
Workaround	No workaround
Fix Status	No fix available

5. I²C Reads are slower when USB-Serial is configured as I²C Master.	
Problem Definition	I ² C reads done by USB-Serial configured as I ² C Master are observed to be slower. This is because of significant delay between the I ² C read initiation and the reception of data from the I ² C Slave.

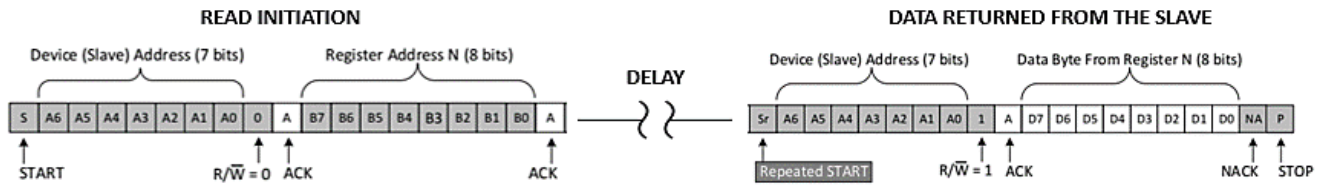

Parameters Affected	NA
Trigger Condition(s)	No specific trigger condition. The delay is observed between every I ² C Read initiation from the master and reception of slave data
Scope of Impact	I ² C read operations from the master are slower.
Workaround	KBA227320 mentions the steps needed to be taken for reducing this delay.
Fix Status	No fix. Workaround is proven.

6. USB-Serial does not report UART Frame Errors.	
Problem Definition	USB-Serial does not report UART Frame Errors while receiving UART data when the number of stop bits is set as 1.
Parameters Affected	NA
Trigger Condition(s)	USB-Serial fails to report a UART Frame error when the number of stop bits is set as 1. It correctly reports the error when the stop bits is not 1
Scope of Impact	No impact
Workaround	No workaround. In general, applications using UART will have to include checksum or CRC in the data to ensure frame integrity.
Fix Status	No fix

7. USB-Serial does not report MARK or SPACE Parity errors.	
Problem Definition	USB-Serial does not report UART Parity error while receiving the data when configured for MARK or SPACE parity.
Parameters Affected	NA
Trigger Condition(s)	USB Serial fails to report UART Parity errors while receiving data when configured for MARK or SPACE parity. Note that USB-Serial detects parity errors when configured for ODD or EVEN parity settings.
Scope of Impact	No impact
Workaround	No workaround. In general, applications using UART will have to include checksum or CRC in the data to ensure frame integrity.
Fix Status	No fix

Revision history

Document revision	Date	Description of changes
*G	2014-02-21	Updated Ordering information (Updated part numbers).
*H	2014-07-11	<p>Updated Features.</p> <p>Updated Functional overview:</p> <p>Updated JTAG interface:</p> <p>Updated description.</p> <p>Updated Software:</p> <p>Updated Drivers for Windows operating systems:</p> <p>Updated description.</p> <p>Updated Electrical specifications:</p> <p>Updated Device level specifications:</p> <p>Updated Table 4:</p> <p>Updated details in “Details/Conditions” column of V_{BUS} and V_{DD} parameters.</p> <p>Updated typical and maximum values of I_{DD1} parameter.</p> <p>Updated details in “Details/Conditions” column of I_{DD1} parameter.</p> <p>Updated Table 5:</p> <p>Removed F1 and F2 parameters and their details.</p> <p>Updated GPIO:</p> <p>Updated Table 6:</p> <p>Updated details in “Description” column of V_{OH} and V_{OL} parameters.</p> <p>Updated Pin description:</p> <p>Updated Table 18:</p> <p>Updated details in “Mode 7” column of pin 6 and pin 7.</p> <p>Updated USB power configurations:</p> <p>Updated Self-powered configuration:</p> <p>Updated description.</p> <p>Updated Figure 5.</p> <p>Updated Application examples:</p> <p>Updated CAPSENSE™:</p> <p>Updated description.</p> <p>Updated Figure 12.</p> <p>Completing Sunset Review.</p>

Revision history

Document revision	Date	Description of changes
*I	2015-06-23	<p>Updated Features. Updated Functional overview: Updated Serial communication: Updated UART interface: Updated description. Updated I2C interface: Updated description. Updated System resources: Updated Power system: Updated description. Updated Internal 32-kHz oscillator: Updated description. Updated Reset: Updated description. Updated Software: Updated Drivers for Windows operating systems: Updated description. Updated Windows-CE support: Updated description. Updated Electrical specifications: Updated Operating conditions: Updated details corresponding to V_{BUS} supply voltage. Updated Device level specifications: Updated Table 4: Changed maximum value of V_{BUS} parameter from 5.25 V to 5.5 V. Updated GPIO: Updated Table 6: Updated details in “Description” column of V_{OH} and V_{OL} parameters. Updated Pin description: Updated details in “Description” column of pin 19. Updated Application examples: Updated USB to dual channel (I2C/SPI) bridge: Updated description. Updated to new template. Completing Sunset Review.</p>

Revision history

Document revision	Date	Description of changes
*J	2015-12-24	<p>Updated Document Title to read as “CY7C65215/CY7C65215A, USB-Serial Dual Channel (UART/I²C/SPI) Bridge with CAPSENSE™ and BCD”.</p> <p>Included details of CY7C65215A part number in all instances across the document.</p> <p>Updated Features: Updated description. Added CY7C65215 and CY7C65215A features comparison. Added More Information.</p> <p>Updated Functional overview: Updated Serial communication: Added Table 2. Updated UART interface: Updated description. Updated UART flow control: Updated description. Updated SPI interface: Updated description. Updated Electrical specifications: Updated Operating conditions: Updated details corresponding to “V_{BUS} supply voltage”. Updated Device level specifications: Updated Table 4: Changed maximum value of V_{BUS} parameter from 5.5 V to 5.25 V. Updated details in “Details/Conditions” column corresponding to I_{DD2} parameter. Updated Pin description: Updated details in “Description” column corresponding to V_{BUS} pin. Updated USB power configurations: Updated USB bus-powered configuration: Updated Figure 4. Updated Self-powered configuration: Updated Figure 5. Updated USB bus powered with variable I/O voltage: Updated Figure 6. Updated Application examples: Updated USB-to-dual UART bridge with battery-charge detection: Updated Figure 7. Added USB to RS485 application. Updated CAPSENSE™: Updated Figure 12. Updated USB to dual channel (I2C/SPI) bridge: Updated Figure 13. Updated Ordering information: Updated part numbers. Updated Ordering code definitions.</p>
*K	2017-05-04	Updated Cypress Logo and Copyright.
*L	2018-03-21	<p>Updated Ordering information: No change in part numbers. Replaced “Tube” with “Tray” in Ordering code definitions.</p>
*M	2019-06-11	<p>Added Errata. Updated to new template. Completing Sunset Review.</p>
*N	2023-04-26	<p>Updated Features: Updated description. Migrated to Infineon template.</p>

Trademarks

All referenced product or service names and trademarks are the property of their respective owners.

Edition 2023-04-26

Published by

Infineon Technologies AG
81726 Munich, Germany

© 2023 Infineon Technologies AG.
All Rights Reserved.

Do you have a question about this document?

Email:

erratum@infineon.com

Document reference

001-81006 Rev. *N

IMPORTANT NOTICE

The information given in this document shall in no event be regarded as a guarantee of conditions or characteristics ("Beschaffenheitsgarantie").

With respect to any examples, hints or any typical values stated herein and/or any information regarding the application of the product, Infineon Technologies hereby disclaims any and all warranties and liabilities of any kind, including without limitation warranties of non-infringement of intellectual property rights of any third party.

In addition, any information given in this document is subject to customer's compliance with its obligations stated in this document and any applicable legal requirements, norms and standards concerning customer's products and any use of the product of Infineon Technologies in customer's applications.

The data contained in this document is exclusively intended for technically trained staff. It is the responsibility of customer's technical departments to evaluate the suitability of the product for the intended application and the completeness of the product information given in this document with respect to such application.

WARNINGS

Due to technical requirements products may contain dangerous substances. For information on the types in question please contact your nearest Infineon Technologies office.

Except as otherwise explicitly approved by Infineon Technologies in a written document signed by authorized representatives of Infineon Technologies, Infineon Technologies' products may not be used in any applications where a failure of the product or any consequences of the use thereof can reasonably be expected to result in personal injury.