

SPECIFICATIONS

(RoHS Compliant)

Model Number: SD48B1
Part Number: 19028935A

SPEC Number: 26013993A01

Jan.01.2013



Mechanical Drawing:

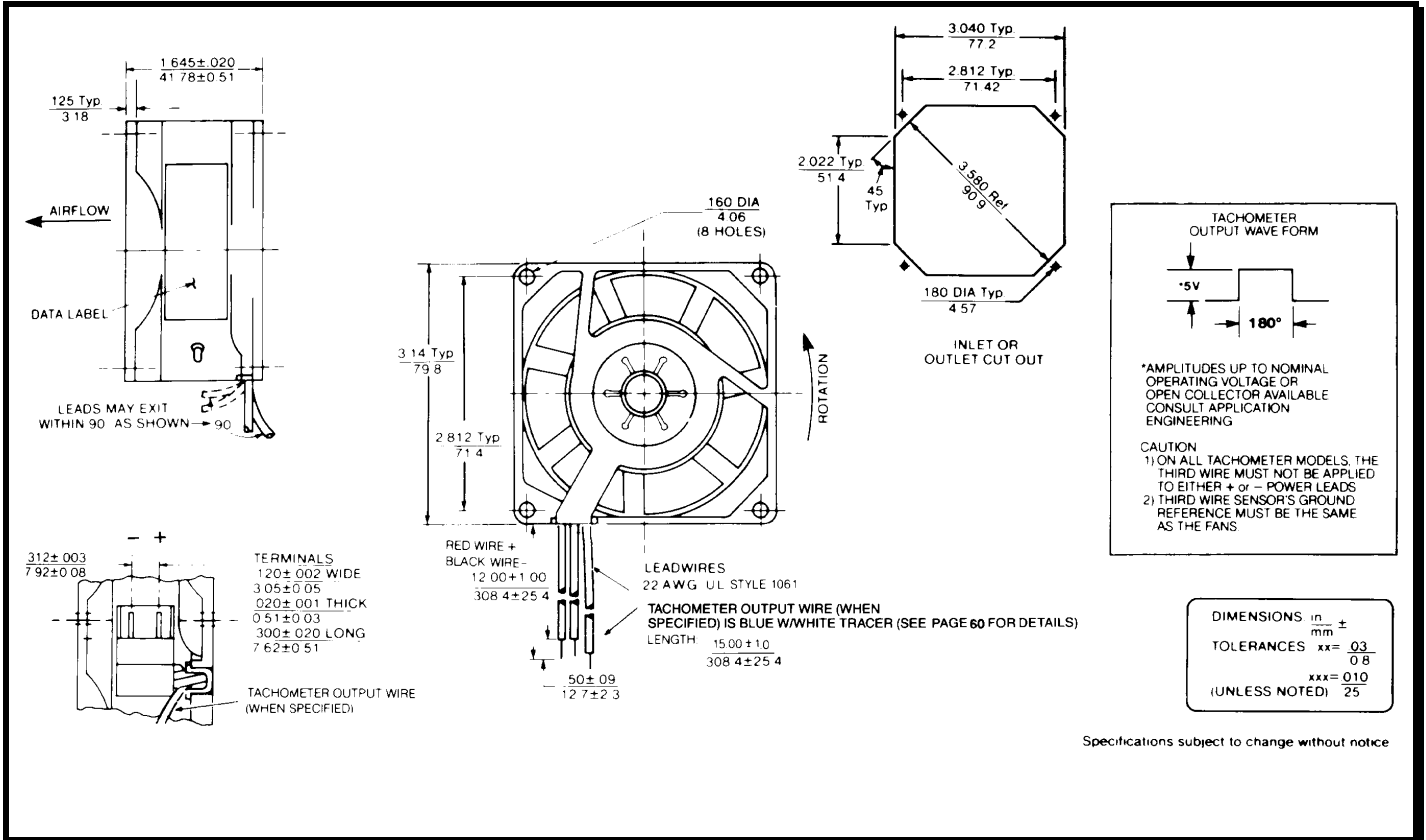

Motor:

Nominal Voltage = 48 vdc
 Operating Voltage Range = 24 – 56 vdc
 Nominal Running Current = 0.060 amps
 Locked Rotor Current = 0.300 amps
 Running Power = 3.0 watts
 Average Speed = 3500
 Bearings = Ball
 Airflow = 35 CFM
 Acoustic = 47.6 dBA

Construction:

Venturi: One Piece Die-Cast Zinc Alloy, Black
 Propeller: Plastic, Black, UL 94V-0

Life Expectancy:

This fan is designed for continuous duty life of 83,000 hours at 40°C

Additional Features:

Brushless DC Motor
 Locked Rotor Protection
 Automatic Restart Capability
 Polarity Protected
 Operating temperature: -10°C to 70°C
 Storage Temperature: -40°C to 85°C

Termination:

12" leadwires, AWG 22, UL 1061
 Red: = Power (+)
 Black: = Return (-)

Agency Approvals:

UL, CE