

used for: D-SUB

Part-No.	No. of pos.	A -0.76	B -0.25	C
164A10119X	9	31.19	16.46	25.00 <sup>+0.12</sup> / <sub>-0.13</sub>
164A10129X	15	39.52	24.79	33.30 <sup>+0.15</sup> / <sub>-0.1</sub>
164A10139X	25	53.42	38.50	47.04 ±0.13
164A10149X	37	69.70	54.96	63.50 ±0.13

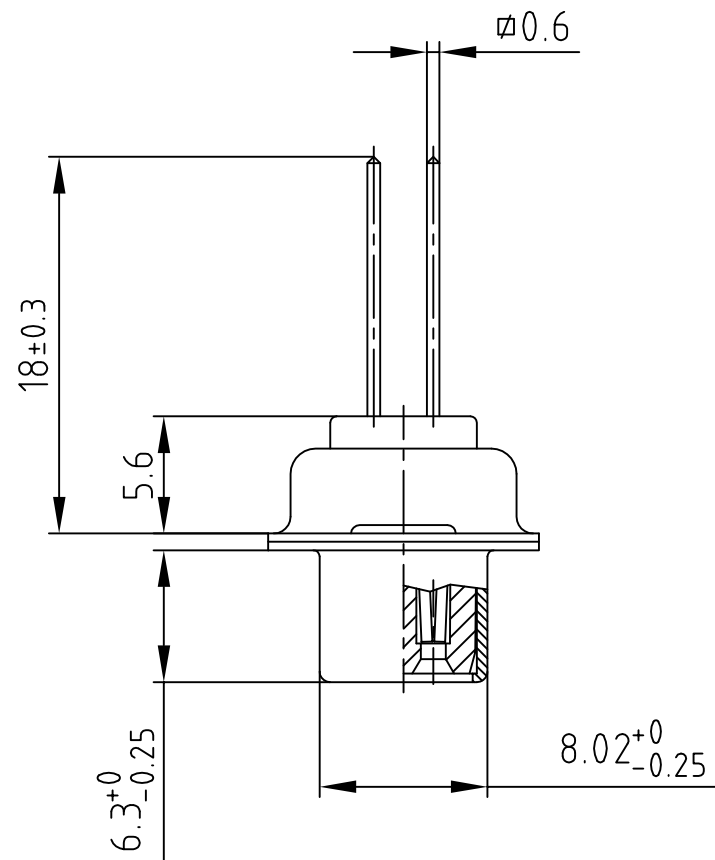
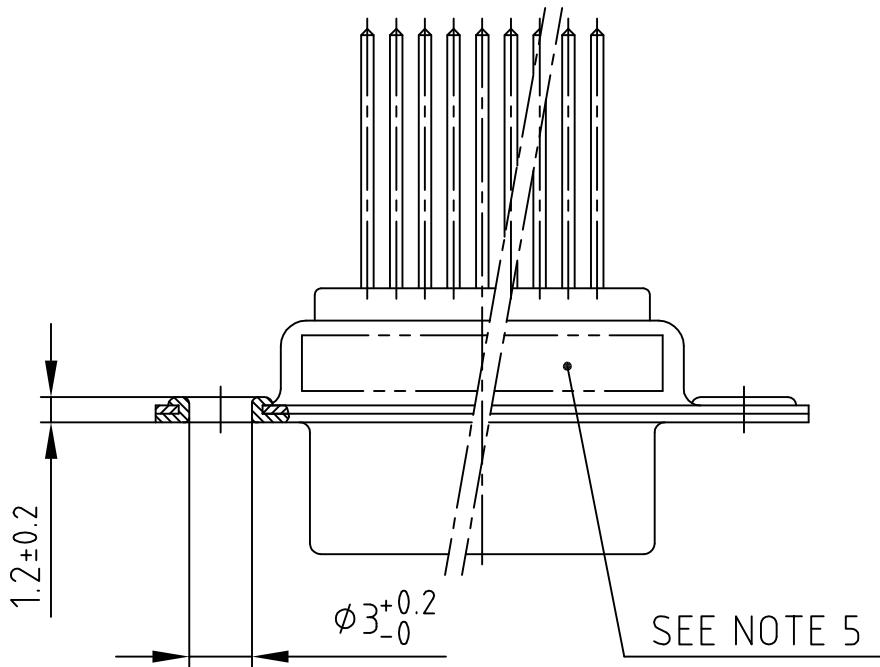
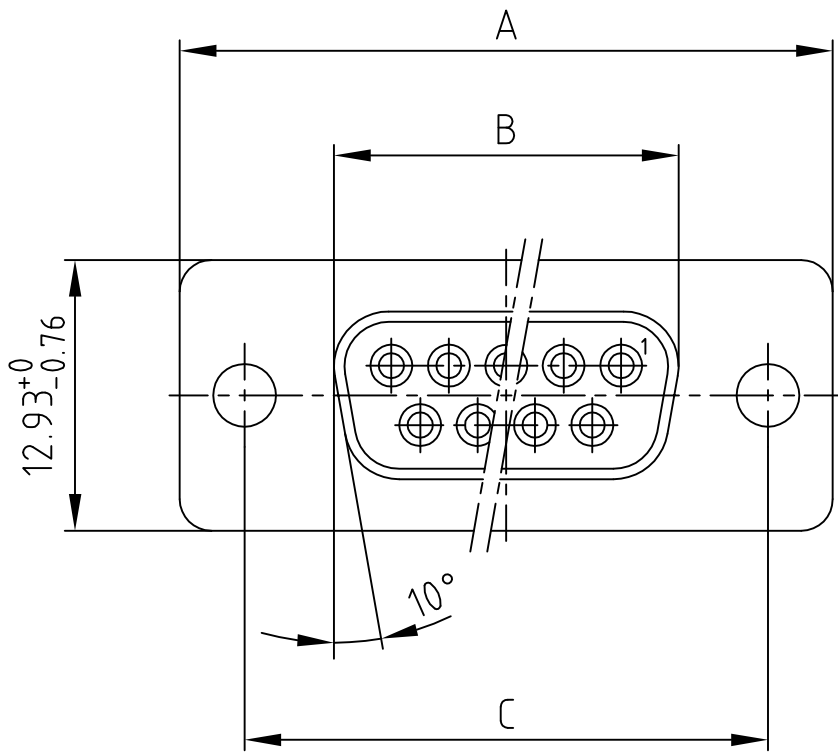

NOTES:

1. METALSHELLS: STEEL; min. 320µin TIN
2. INSULATORS: PBT GF UL 94 V-0; BLACK
3. CONTACTS: COPPER ALLOY
4. PLATING: min. 8µin HARD GOLD over min. 50µin NICKEL
5. CONNECTOR IS PART MARKED: PART-NO. CONEC ABC

Directive 2002/95/EC RoHS compliant

THIS DRAWING MAY NOT BE COPIED OR REPRODUCED IN ANY WAY, AND MAY NOT BE PASSED ON TO A THIRD PARTY WITHOUT WRITTEN PERMISSION.  
 OWNERSHIP AND COPYRIGHT OF CONEC GmbH  
 DO NOT ALTER CAD DRAWING BY HAND

rev.	description	date	name

tolerance	
2002	date
drawn	15.05. E. Mickenbecker
appd.	15.05. J. Resonnek
norm	DIN 41652
d-old	
<b>CONEC®</b>	

scale:	2:1
material:	SEE NOTES
title:	D-SUB FEMALE 9-37pos. WIRE WRAP
dwg no:	AutoCAD 2000
part no:	SEE TABLE
DIN-A	4
sh:	1/1

