

SPECIFICATIONS

| PARAMETERS | VALUES | UNITS |
|---|------------|-------|
| RATED INPUT POWER | 20 | W |
| MAX INPUT POWER | 40 | W |
| IMPEDANCE | 4± 15% | OHM |
| RESONANT FREQUENCY | 480± 20% | Hz |
| AVG. SPL 2.83V/0.1M ON 4MM THICK PLA PANEL (AVG 0.5, 1.0, 2.0, AND 5.0 kHz) | 107 | dBA |
| FREQUENCY RANGE (MATERIAL DEPENDANT) | 60~ 20,000 | Hz |
| MAGNET MATERIAL | NdFeB | - |
| OPERATING TEMPERATURE | -20~ +60 | °C |
| WEIGHT | 114 | grams |

THIS DOCUMENT CONTAINS DATA PROPRIETARY TO PROJECTS UNLIMITED, INC. ANY USE OR REPRODUCTION, IN ANY FORM, WITHOUT PRIOR WRITTEN PERMISSION OF PROJECTS UNLIMITED, INC. IS PROHIBITED.
©2003, Projects Unlimited Inc.

REVISION HISTORY

| LTR | DESCRIPTION | DATE | APPROVED |
|-----|---|----------|----------|
| - | RELEASED FROM ENGINEERING | 1/31/17 | |
| A | REVISED THREADS ON MAGNET FROM M4 TO M3 | 3/6/2020 | M.V. |

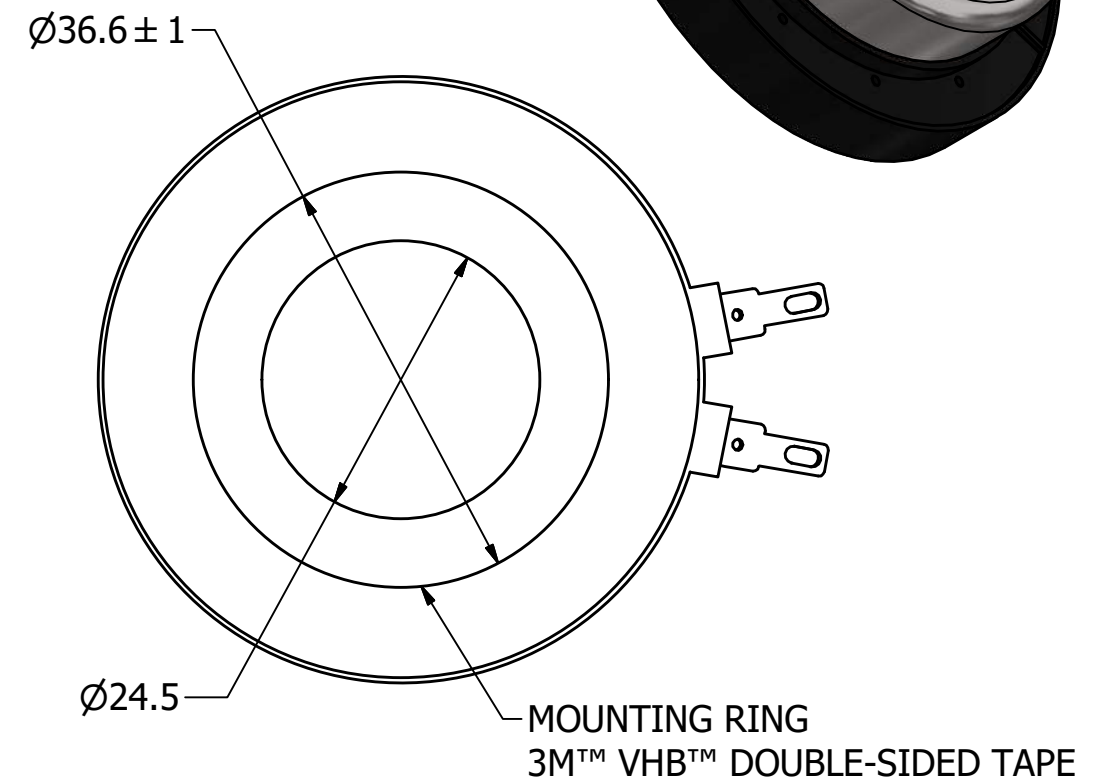
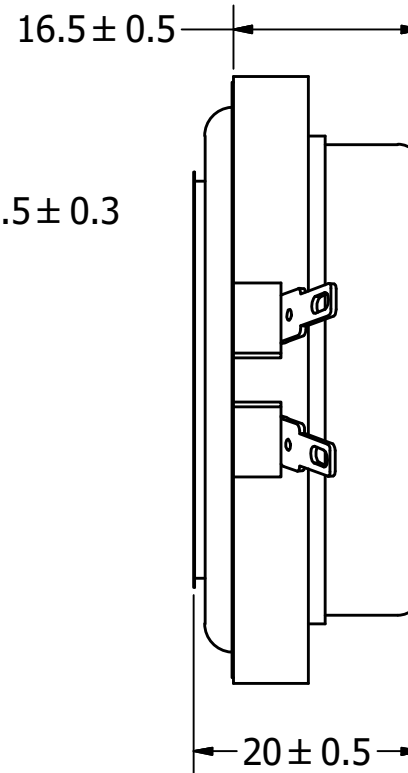
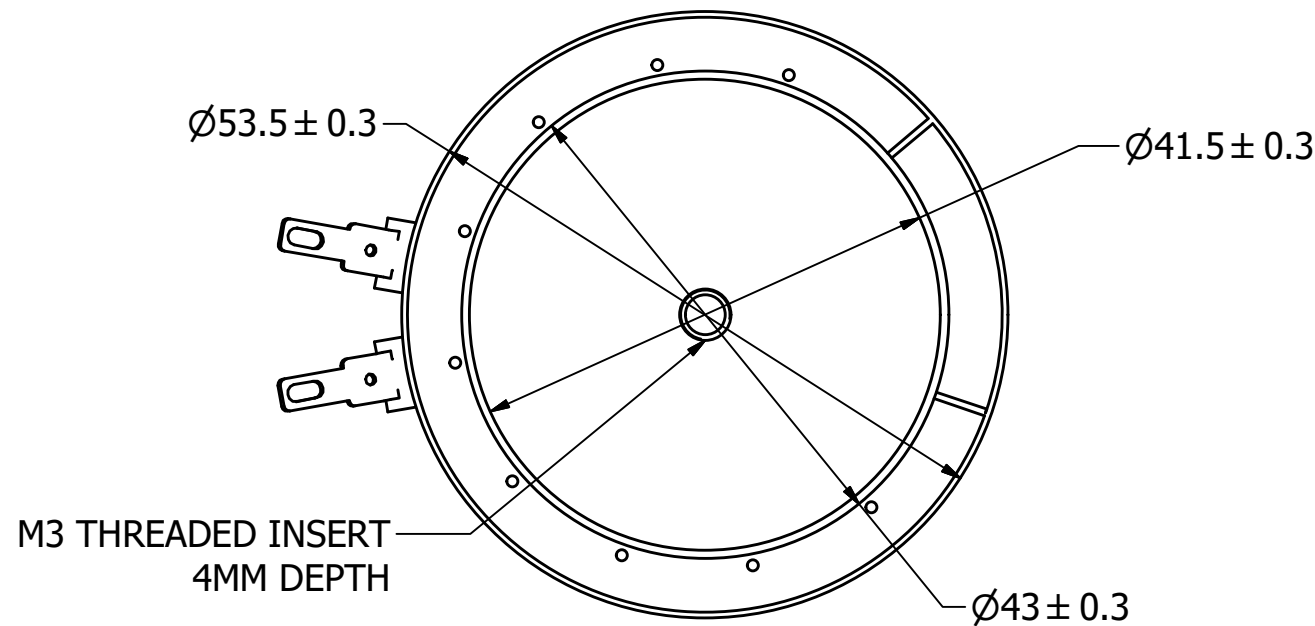
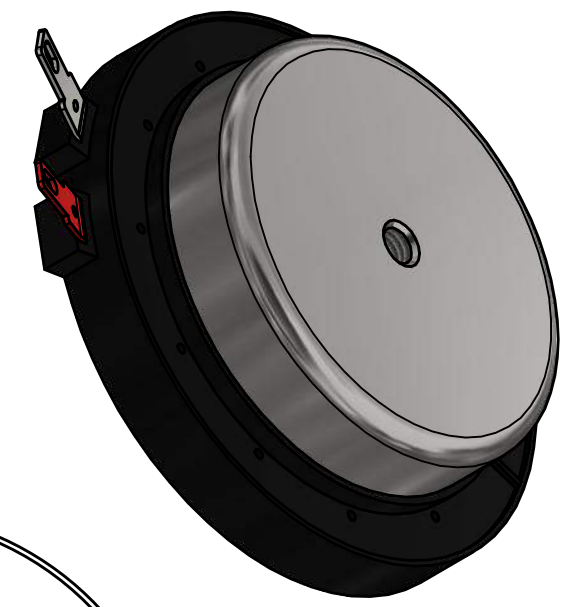

NOTES:

1. ALL DIMENSIONS ARE IN MILLIMETERS.
2. SPECIFICATIONS SUBJECT TO CHANGE OR WITHDRAWL WITHOUT NOTICE.
3. THIS PART IS RoHS 2011/65/EU COMPLIANT.
4. FOR APPLICATIONS THAT ARE TO BE SUBJECTED TO EXTERNAL FORCE, SHOCK, OR VIBRATION, PUI AUDIO RECOMMENDS SOLID MECHANICAL REINFORCEMENT TO ENSURE RIGID COUPLING BEYOND THAT PROVIDED BY THE 3M™ VHB™ F-9473PC DOUBLE-SIDED TAPE.

| | | | | | | | | | |
|--|-------------------|---|-----------|---|-----------|-------------|-----------|------------|-------|
| UNLESS OTHERWISE SPECIFIED: DIMENSIONS ARE IN MILLIMETERS, TOLERANCES ARE ±0.5 AND ANGLES ARE ±3°. | SIZE A3 | Designed by | Date | Checked by | Date | Approved by | Date | Drawn Date | |
| | | M.V. | 1/31/2017 | M.V. | 1/31/2017 | B.R. | 1/31/2017 | 1/31/2017 | |
| ASX05404-HD-R.idw | |  | | ASX05404-HD-R High Definition Exciter | | | | Edition | Sheet |
| | | | | | | | | - | 1 / 1 |