

# 18Mb DDR SIO SRAM 2-WORD BURST

**MT57W2MH8C  
MT57W1MH18C  
MT57W512H36C**

## Features

- DLL circuitry for accurate output data placement
- Separate independent read and write data ports
- DDR READ or WRITE operation initiated each cycle
- Fast clock to valid data times
- Full data coherency, providing most current data
- Two-tick burst counter for low DDR transaction size
- Double data rate operation on read and write ports
- Two input clocks (K and K#) for precise DDR timing at clock rising edges only
- Two output clocks (C and C#) for precise flight time and clock skew matching—clock and data delivered together to receiving device
- Optional-use echo clocks (CQ and CQ#) for flexible receive data synchronization
- Single address bus
- Simple control logic for easy depth expansion
- Internally self-timed, registered writes
- Core V<sub>DD</sub> = 1.8V (±0.1V); I/O V<sub>DDQ</sub> = 1.5V to V<sub>DD</sub> (±0.1V) HSTL
- Clock-stop capability with  $\mu$ s restart
- 13mm x 15mm, 1mm pitch, 11 x 15 grid FBGA package
- User-programmable impedance output
- JTAG boundary scan

## Options

- Clock Cycle Timing
 

3ns (333 MHz)	-3
3.3ns (300 MHz)	-3.3
4ns (250 MHz)	-4
5ns (200 MHz)	-5
6ns (167 MHz)	-6
7.5ns (133 MHz)	-7.5
- Configurations
 

2 Meg x 8	MT57W2MH8C
1 Meg x 18	MT57W1MH18C
512K x 36	MT57W512H36C
- Package
 

165-ball, 13mm x 15mm FBGA	F
----------------------------	---
- Operating Temperature Range
 

Commercial (0°C ≤ T <sub>A</sub> ≤ +70°C)	None
---	------

## Marking<sup>1</sup>

### NOTE:

1. A Part Marking Guide for the FBGA devices can be found on Micron's Web site—<http://www.micron.com/numberguide>.

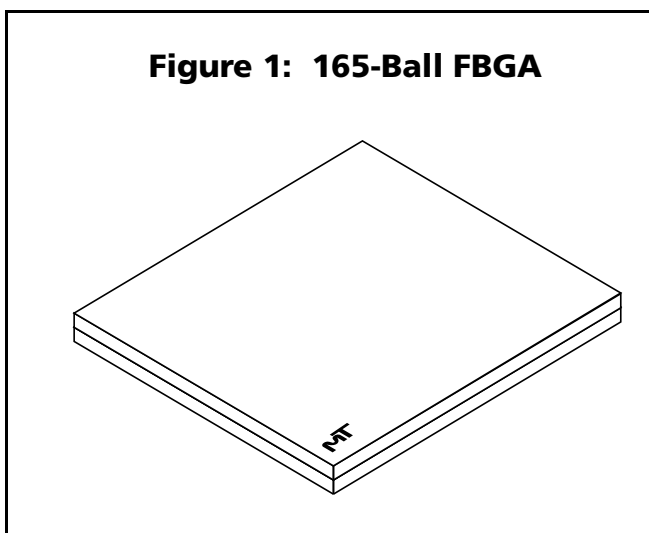

**Figure 1: 165-Ball FBGA**

**Table 1: Valid Part Numbers**

PART NUMBER	DESCRIPTION
MT57W2MH8CF-xx	2 Meg x 8, DDR SIOb2 FBGA
MT57W1MH18CF-xx	1 Meg x 18, DDR SIOb2 FBGA
MT57W512H36CF-xx	512K x 36, DDR SIOb2 FBGA

## General Description

The Micron<sup>®</sup> DDR separate I/O, synchronous, pipelined burst SRAM employs high-speed, low-power CMOS designs using an advanced 6T CMOS process.

The DDR architecture consists of two separate DDR (double data rate) ports to access the memory array. The read port has dedicated data outputs to support READ operations. The write port has dedicated data inputs to support WRITE operations. This architecture eliminates the need for high-speed bus turnaround. Access to each port is accomplished using a common address bus. Addresses for reads and writes are latched on the rising edge of the K input clock. Each address location is associated with two words that burst sequentially into or out of the device. Bus turnaround cycles are eliminated and a new data transaction can be requested each clock cycle, permitting higher request rates than DDR SRAMs without separated input and output buses.

Depth expansion is accomplished with a single device select (LD#), which is received at K rising edge. All synchronous inputs pass through registers controlled by the K or K# input clock rising edges. Active LOW byte writes (BWx#) permit byte write or nibble write selection. Write data and byte writes are registered on the rising edges of both K and K#. The addressing within each burst of two is fixed and sequential, beginning with the lowest address and ending with the highest address. All synchronous data outputs pass through output registers controlled by the rising edges of the output clocks (C and C# if provided, otherwise K, K#).

Four balls are used to implement JTAG test capabilities: test mode select (TMS), test data-in (TDI), test clock (TCK), and test data-out (TDO). JTAG circuitry is used to serially shift data to and from the SRAM. JTAG inputs use JEDEC-standard 1.8V I/O levels to shift data during this testing mode of operation.

The SRAM operates from a 1.8V power supply, and all inputs and outputs are HSTL-compatible. The device is ideally suited for applications that require a new transaction to be initiated each clock cycle.

Please refer to Micron's Web site ([www.micron.com/sramds](http://www.micron.com/sramds)) for the latest data sheet.

## READ/WRITE Operations

All bus transactions operate on an uninterruptable burst-of-two data and require one full clock cycle of bus utilization. Any transaction type can be initiated at K rising edge independent of the previous transaction type. This permits any random operation without ever needing bus turnaround delays.

READ cycles are pipelined. The request is initiated by driving R/W# HIGH and providing the address at K rising edge. Data is delivered after the next rising edge of K# (t + 1), using C and C# as the output timing references; or K and K# if C and C# are tied HIGH. If C and C# are tied HIGH, they may not be toggled during device operation. Output tri-stating is automatically controlled so that the bus is released if no data is being delivered. This permits banked SRAM systems with no complex output enable (OE) timing generation. Back-to-back READ cycles can be initiated at every K rising edge.

WRITE cycles are initiated by driving R/W# LOW and providing the address at K rising edge. Data is expected at the rising edge of K and K#, beginning at the next K rising edge after the cycle is initiated. Write registers are incorporated to facilitate pipelined self-timed WRITE cycles and to provide fully coherent data for all combinations of reads and writes. A read can immediately follow a write even if they are to the same address. Although the write data has not been written to the memory array, the SRAM will deliver the data from the write register instead of using the older data from the memory array. The latest data is always utilized for all bus transactions. WRITE cycles can be initiated on every K rising edge.

## PARTIAL WRITE Operations

BYTE WRITE operations are supported, except for x8 devices in which nibble write is supported. The active LOW byte write controls, BWx# (NWx#), are registered coincident with their corresponding data. This feature can eliminate the need for some READ-MODIFY-WRITE cycles, collapsing it to a single BYTE/NIBBLE WRITE operation in some instances.

## Programmable Impedance Output Buffer

The DDR SRAM is equipped with programmable impedance output buffers. This allows a user to match the driver impedance to the system. To adjust the impedance, an external precision resistor (RQ) is connected between the ZQ ball and V<sub>SS</sub>. The value of the resistor must be five times the desired impedance. For example, a 350Ω resistor is required for an output impedance of 70Ω. To ensure that output impedance is one-fifth the value of RQ (within 15 percent), the range of RQ is 175Ω to 350Ω. Alternately, the ZQ ball can be connected directly to V<sub>DDQ</sub>, which will place the device in a minimum impedance mode.

Output impedance updates may be required because, over time, variations may occur in supply voltage and temperature. The device samples the value of RQ. Impedance updates are transparent to the system; they do not affect device operation, and all data sheet timing and current specifications are met during an update.

The device will power up with an output impedance set at 50Ω. To guarantee optimum output driver impedance after power-up, the SRAM needs 1,024 cycles to update the impedance. The user can operate the part with fewer than 1,024 clock cycles, but optimal output impedance is not guaranteed.

## Clock Considerations

This device utilizes internal delay-locked loops for maximum output, data valid window. It can be placed into a stopped-clock state to minimize power, with a

modest restart time of 1,024 clock cycles. Circuitry automatically resets the DLL when the absence of an input clock is detected. See Micron Technical Note TN-54-02 for more information on clock DLL start-up procedures.

Optional-use echo clocks are provided to precisely indicate data validity. Data changes occur very near to the rising edges of CQ and CQ#.

## Single Clock Mode

The SRAM can be used with the single K and K# clock pair by tying C and C# HIGH. In this mode, the SRAM will use K and K# in place of C and C#. This mode provides the most rapid data output but does not compensate for system clock skew and flight times.

The output echo clocks are precise references to output data. CQ and CQ# are both rising edge and falling edge accurate and are 180° out of phase. Either or both may be used for output data capture. K or C rising edge triggers CQ rising and CQ# falling edge. CQ rising edge indicates first data response for QDRI and DDRI (version 1, non-DLL) SRAM, while CQ# rising edge indicates first data response for QDRII and DDRII (version 2, DLL) SRAM.

## Depth Expansion

Depth expansion is easily done by providing a new LD# signal for each bank. R/W# can be shared among all SRAMs in the system, if driver fanout permits.

**Figure 2: Functional Block Diagram**  
**2 Meg x 8; 1 Meg x 18; 512K x 36**

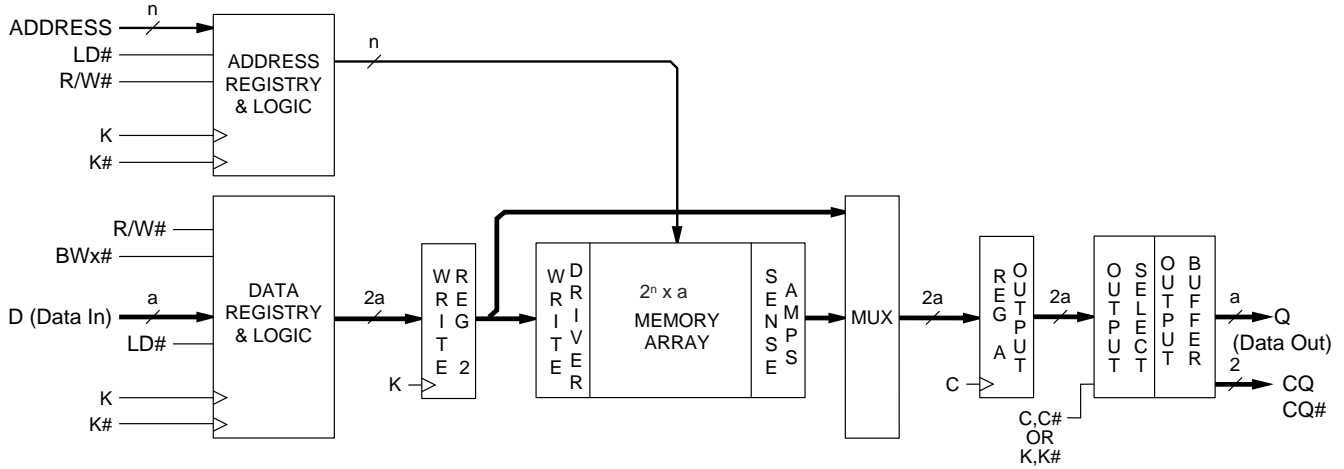

**NOTE:**

1. The functional block diagram illustrates simplified device operation. See truth table, ball descriptions, and timing diagrams for detailed information.
2. For 2 Meg x 8, n = 21, a = 8; NWx# = 2 separate nibble writes.  
 For 1 Meg x 18, n = 20, a = 18; BWx# = 2 separate byte writes.  
 For 512K x 36, n = 19, a = 36; BWx# = 4 separate byte writes.

**Figure 3: Application Example**

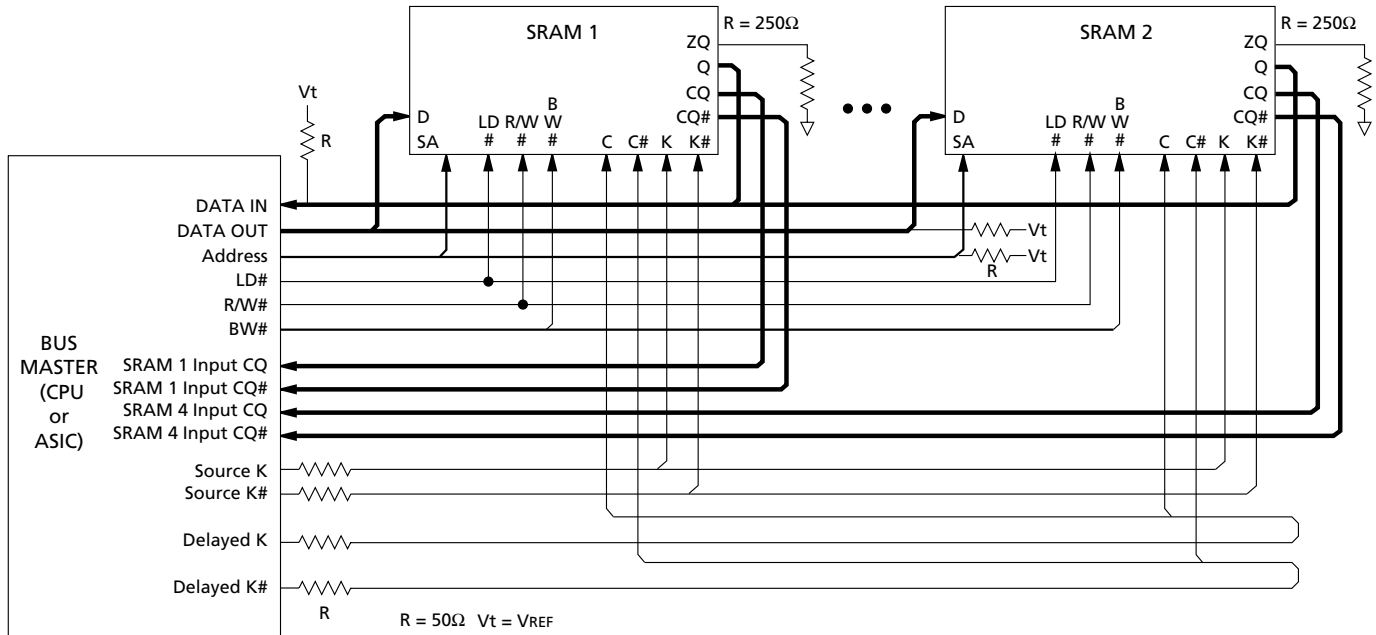

**NOTE:**

1. In this approach, the second clock pair drives the C and C# clocks but is delayed such that return data meets setup and hold times at the bus master.
2. Consult Micron Technical Notes for more thorough discussions of clocking schemes.
3. Data capture is possible using only one of the two signals. CQ and CQ# clocks are optional use outputs.
4. For high frequency applications (200 MHz and faster) the CQ and CQ# clocks (for data capture) are recommended over the C and C# clocks (for data alignment). The C and C# clocks are optional use inputs.

**Table 2: 2 Meg x 8 Ball Layout (Top View)  
165-Ball FBGA**

	1	2	3	4	5	6	7	8	9	10	11
<b>A</b>	CQ#	V <sub>SS</sub> /SA <sup>1</sup>	SA	R/W#	NW1# <sup>2</sup>	K#	NC/SA <sup>3</sup>	LD#	SA	V <sub>SS</sub> /SA <sup>4</sup>	CQ
<b>B</b>	NC	NC	NC	SA	NC/SA <sup>5</sup>	K	NW0# <sup>6</sup>	SA	NC	NC	Q3
<b>C</b>	NC	NC	NC	V <sub>SS</sub>	SA	SA	SA	V <sub>SS</sub>	NC	NC	D3
<b>D</b>	NC	D4	NC	V <sub>SS</sub>	V <sub>SS</sub>	V <sub>SS</sub>	V <sub>SS</sub>	V <sub>SS</sub>	NC	NC	NC
<b>E</b>	NC	NC	Q4	V <sub>DDQ</sub>	V <sub>SS</sub>	V <sub>SS</sub>	V <sub>SS</sub>	V <sub>DDQ</sub>	NC	D2	Q2
<b>F</b>	NC	NC	NC	V <sub>DDQ</sub>	V <sub>DD</sub>	V <sub>SS</sub>	V <sub>DD</sub>	V <sub>DDQ</sub>	NC	NC	NC
<b>G</b>	NC	D5	Q5	V <sub>DDQ</sub>	V <sub>DD</sub>	V <sub>SS</sub>	V <sub>DD</sub>	V <sub>DDQ</sub>	NC	NC	NC
<b>H</b>	DLL#	V <sub>REF</sub>	V <sub>DDQ</sub>	V <sub>DDQ</sub>	V <sub>DD</sub>	V <sub>SS</sub>	V <sub>DD</sub>	V <sub>DDQ</sub>	V <sub>DDQ</sub>	V <sub>REF</sub>	ZQ
<b>J</b>	NC	NC	NC	V <sub>DDQ</sub>	V <sub>DD</sub>	V <sub>SS</sub>	V <sub>DD</sub>	V <sub>DDQ</sub>	NC	Q1	D1
<b>K</b>	NC	NC	NC	V <sub>DDQ</sub>	V <sub>DD</sub>	V <sub>SS</sub>	V <sub>DD</sub>	V <sub>DDQ</sub>	NC	NC	NC
<b>L</b>	NC	Q6	D6	V <sub>DDQ</sub>	V <sub>SS</sub>	V <sub>SS</sub>	V <sub>SS</sub>	V <sub>DDQ</sub>	NC	NC	Q0
<b>M</b>	NC	NC	NC	V <sub>SS</sub>	V <sub>SS</sub>	V <sub>SS</sub>	V <sub>SS</sub>	V <sub>SS</sub>	NC	NC	D0
<b>N</b>	NC	D7	NC	V <sub>SS</sub>	SA	SA	SA	V <sub>SS</sub>	NC	NC	NC
<b>P</b>	NC	NC	Q7	SA	SA	C	SA	SA	NC	NC	NC
<b>R</b>	TDO	TCK	SA	SA	SA	C#	SA	SA	SA	TMS	TDI

**NOTE:**

1. Expansion address: 2A for 72Mb
2. NW1# controls writes to D4:D7
3. Expansion address: 7A for 144Mb
4. Expansion address: 10A for 36Mb
5. Expansion address: 5B for 288Mb
6. NW0# controls writes to D0:D3

**Table 3: 1 Meg x 18 Ball Layout (Top View)  
165-Ball FBGA**

	1	2	3	4	5	6	7	8	9	10	11
<b>A</b>	CQ#	V <sub>SS</sub> /SA <sup>1</sup>	NC/SA <sup>2</sup>	R/W#	BW1# <sup>3</sup>	K#	NC/SA <sup>4</sup>	LD#	SA	V <sub>SS</sub> /SA <sup>5</sup>	CQ
<b>B</b>	NC	Q9	D9	SA	NC	K	BW0# <sup>6</sup>	SA	NC	NC	Q8
<b>C</b>	NC	NC	D10	V <sub>SS</sub>	SA	SA	SA	V <sub>SS</sub>	NC	Q7	D8
<b>D</b>	NC	D11	Q10	V <sub>SS</sub>	V <sub>SS</sub>	V <sub>SS</sub>	V <sub>SS</sub>	V <sub>SS</sub>	NC	NC	D7
<b>E</b>	NC	NC	Q11	V <sub>DDQ</sub>	V <sub>SS</sub>	V <sub>SS</sub>	V <sub>SS</sub>	V <sub>DDQ</sub>	NC	D6	Q6
<b>F</b>	NC	Q12	D12	V <sub>DDQ</sub>	V <sub>DD</sub>	V <sub>SS</sub>	V <sub>DD</sub>	V <sub>DDQ</sub>	NC	NC	Q5
<b>G</b>	NC	D13	Q13	V <sub>DDQ</sub>	V <sub>DD</sub>	V <sub>SS</sub>	V <sub>DD</sub>	V <sub>DDQ</sub>	NC	NC	D5
<b>H</b>	DLL#	V <sub>REF</sub>	V <sub>DDQ</sub>	V <sub>DDQ</sub>	V <sub>DD</sub>	V <sub>SS</sub>	V <sub>DD</sub>	V <sub>DDQ</sub>	V <sub>DDQ</sub>	V <sub>REF</sub>	ZQ
<b>J</b>	NC	NC	D14	V <sub>DDQ</sub>	V <sub>DD</sub>	V <sub>SS</sub>	V <sub>DD</sub>	V <sub>DDQ</sub>	NC	Q4	D4
<b>K</b>	NC	NC	Q14	V <sub>DDQ</sub>	V <sub>DD</sub>	V <sub>SS</sub>	V <sub>DD</sub>	V <sub>DDQ</sub>	NC	D3	Q3
<b>L</b>	NC	Q15	D15	V <sub>DDQ</sub>	V <sub>SS</sub>	V <sub>SS</sub>	V <sub>SS</sub>	V <sub>DDQ</sub>	NC	NC	Q2
<b>M</b>	NC	NC	D16	V <sub>SS</sub>	V <sub>SS</sub>	V <sub>SS</sub>	V <sub>SS</sub>	V <sub>SS</sub>	NC	Q1	D2
<b>N</b>	NC	D17	Q16	V <sub>SS</sub>	SA	SA	SA	V <sub>SS</sub>	NC	NC	D1
<b>P</b>	NC	NC	Q17	SA	SA	C	SA	SA	NC	D0	Q0
<b>R</b>	TDO	TCK	SA	SA	SA	C#	SA	SA	SA	TMS	TDI

**NOTE:**

1. Expansion address: 2A for 144Mb
2. Expansion address: 3A for 36Mb
3. BW1# controls writes to D9:D17
4. Expansion address: 7A for 288Mb
5. Expansion address: 10A for 72Mb
6. BW0# controls writes to D0:D8



**Table 4: 512K x 36 Ball Layout (Top View)  
165-Ball FBGA**

	1	2	3	4	5	6	7	8	9	10	11
<b>A</b>	CQ#	V <sub>SS</sub> /SA <sup>1</sup>	NC/SA <sup>2</sup>	R/W#	BW2# <sup>3</sup>	K#	BW1# <sup>4</sup>	LD#	NC/SA <sup>5</sup>	V <sub>SS</sub> /SA <sup>6</sup>	CQ
<b>B</b>	Q27	Q18	D18	SA	BW3# <sup>7</sup>	K	BW0# <sup>8</sup>	SA	D17	Q17	Q8
<b>C</b>	D27	Q28	D19	V <sub>SS</sub>	SA	SA	SA	V <sub>SS</sub>	D16	Q7	D8
<b>D</b>	D28	D20	Q19	V <sub>SS</sub>	V <sub>SS</sub>	V <sub>SS</sub>	V <sub>SS</sub>	V <sub>SS</sub>	Q16	D15	D7
<b>E</b>	Q29	D29	Q20	V <sub>DDQ</sub>	V <sub>SS</sub>	V <sub>SS</sub>	V <sub>SS</sub>	V <sub>DDQ</sub>	Q15	D6	Q6
<b>F</b>	Q30	Q21	D21	V <sub>DDQ</sub>	V <sub>DD</sub>	V <sub>SS</sub>	V <sub>DD</sub>	V <sub>DDQ</sub>	D14	Q14	Q5
<b>G</b>	D30	D22	Q22	V <sub>DDQ</sub>	V <sub>DD</sub>	V <sub>SS</sub>	V <sub>DD</sub>	V <sub>DDQ</sub>	Q13	D13	D5
<b>H</b>	DLL#	V <sub>REF</sub>	V <sub>DDQ</sub>	V <sub>DDQ</sub>	V <sub>DD</sub>	V <sub>SS</sub>	V <sub>DD</sub>	V <sub>DDQ</sub>	V <sub>DDQ</sub>	V <sub>REF</sub>	ZQ
<b>J</b>	D31	Q31	D23	V <sub>DDQ</sub>	V <sub>DD</sub>	V <sub>SS</sub>	V <sub>DD</sub>	V <sub>DDQ</sub>	D12	Q4	D4
<b>K</b>	Q32	D32	Q23	V <sub>DDQ</sub>	V <sub>DD</sub>	V <sub>SS</sub>	V <sub>DD</sub>	V <sub>DDQ</sub>	Q12	D3	Q3
<b>L</b>	Q33	Q24	D24	V <sub>DDQ</sub>	V <sub>SS</sub>	V <sub>SS</sub>	V <sub>SS</sub>	V <sub>DDQ</sub>	D11	Q11	Q2
<b>M</b>	D33	Q34	D25	V <sub>SS</sub>	V <sub>SS</sub>	V <sub>SS</sub>	V <sub>SS</sub>	V <sub>SS</sub>	D10	Q1	D2
<b>N</b>	D34	D26	Q25	V <sub>SS</sub>	SA	SA	SA	V <sub>SS</sub>	Q10	D9	D1
<b>P</b>	Q35	D35	Q26	SA	SA	C	SA	SA	Q9	D0	Q0
<b>R</b>	TDO	TCK	SA	SA	SA	C#	SA	SA	SA	TMS	TDI

**NOTE:**

1. Expansion address: 2A for 288Mb
2. Expansion address: 3A for 72Mb
3. BW2# controls writes to D18:D26
4. BW1# controls writes to D9:D17
5. Expansion address: 9A for 36Mb
6. Expansion address: 10A for 144Mb
7. BW3# controls writes to D27:D35
8. BW0# controls writes to D0:D8



**Table 5: Ball Descriptions**

SYMBOL	TYPE	DESCRIPTION
BW_ NW_ #	Input	Synchronous Byte Writes (or Nibble Writes on x8): When LOW, these inputs cause their respective bytes to be registered and written if W# had initiated a WRITE cycle. These signals must meet setup and hold times around the rising edges of K and K# for each of the two rising edges comprising the WRITE cycle. See Ball Layout figures for signal to data relationships.
C C#	Input	Output Clock: This clock pair provides a user-controlled means of tuning device output data. The rising edge of C# is used as the output timing reference for first output data. The rising edge of C is used as the output reference for second output data. Ideally, C# is 180 degrees out of phase with C. C and C# may be tied HIGH to force the use of K and K# as the output reference clocks instead of having to provide C and C# clocks. If tied HIGH, these inputs may not be allowed to toggle during device operation.
D_	Input	Synchronous Data Inputs: Input data must meet setup and hold times around the rising edges of K and K# during WRITE operations. See Ball Layout figures for ball site location of individual signals. The x8 device uses D0:D7. Remaining signals are NC. The x18 device uses D0:D17. Remaining signals are NC. The x36 device uses D0:D35. Remaining signals are NC.
DLL#	Input	DLL Disable: When LOW, this input causes the DLL to be bypassed for stable, low-frequency operation.
K K#	Input	Input Clock: This input clock pair registers address and control inputs on the rising edge of K, and registers data on the rising edge of K and the rising edge of K#. K# is ideally 180 degrees out of phase with K. All synchronous inputs must meet setup and hold times around the clock rising edges.
LD#	Input	Synchronous Load: This input is brought LOW when a bus cycle sequence is to be defined. This definition includes address and read/write direction. All transactions operate on a burst of two data (one clock period of bus activity).
R/W#	Input	Synchronous Read/Write Input: When LD# is LOW, this input designates the access type (READ when R/W# is HIGH, WRITE when R/W# is LOW) for the loaded address. R/W# must meet the setup and hold times around the rising edge of K.
SA	Input	Synchronous Address Inputs: These inputs are registered and must meet the setup and hold times around the rising edge of K. See Ball Layout figures for address expansion inputs. All transactions operate on a burst of two words (one clock period of bus activity). These inputs are ignored when both ports are deselected.
TCK	Input	IEEE 1149.1 Clock Input: 1.8V I/O levels. This ball must be tied to V <sub>SS</sub> if the JTAG function is not used in the circuit.
TMS TDI	Input	IEEE 1149.1 Test Inputs: 1.8V I/O levels. These balls may be left Not Connected if the JTAG function is not used in the circuit.
VREF	Input	HSTL Input Reference Voltage: Nominally V <sub>DDQ</sub> /2 but may be adjusted to improve system noise margin. Provides a reference voltage for the HSTL input buffer trip point.
ZQ	Input	Output Impedance Matching Input: This input is used to tune the device outputs to the system data bus impedance. DQ output impedance is set to 0.2 x R <sub>Q</sub> , where R <sub>Q</sub> is a resistor from this ball to ground. Alternately, this ball can be connected directly to V <sub>DDQ</sub> to enable the minimum impedance mode. This ball cannot be connected directly to GND or left unconnected.
CQ#, CQ	Output	Synchronous Echo Clock Outputs: The edges of these outputs are tightly matched to the synchronous data outputs and can be used as data valid indication. These signals run freely and do not stop when Q tri-states.
Q_	Output	Synchronous Data Outputs: Output data is synchronized to the respective C and C# or to K and K# rising edges if C and C# are tied HIGH. This bus operates in response to R# commands. See Ball Layout figures for ball site location of individual signals. The x8 device uses Q0:Q7. Remaining signals are NC. The x18 device uses Q0:Q17. Remaining signals are NC. The x36 device uses Q0:Q35. Remaining signals are NC.
TDO	Output	IEEE 1149.1 Test Output: 1.8V I/O level.
VDD	Supply	Power Supply: 1.8V nominal. See DC Electrical Characteristics and Operating Conditions for range.
VDDQ	Supply	Power Supply: Isolated Output Buffer Supply: Nominally, 1.5V. 1.8V is also permissible. See DC Electrical Characteristics and Operating Conditions for range.



**Table 5: Ball Descriptions (Continued)**

SYMBOL	TYPE	DESCRIPTION
V <sub>SS</sub>	Supply	Power Supply: GND.
NC	–	No Connect: These balls are internally connected to the die, but have no function and may be left not connected to the board to minimize ball count.

**Figure 4:**  
**Bus Cycle State Diagram**

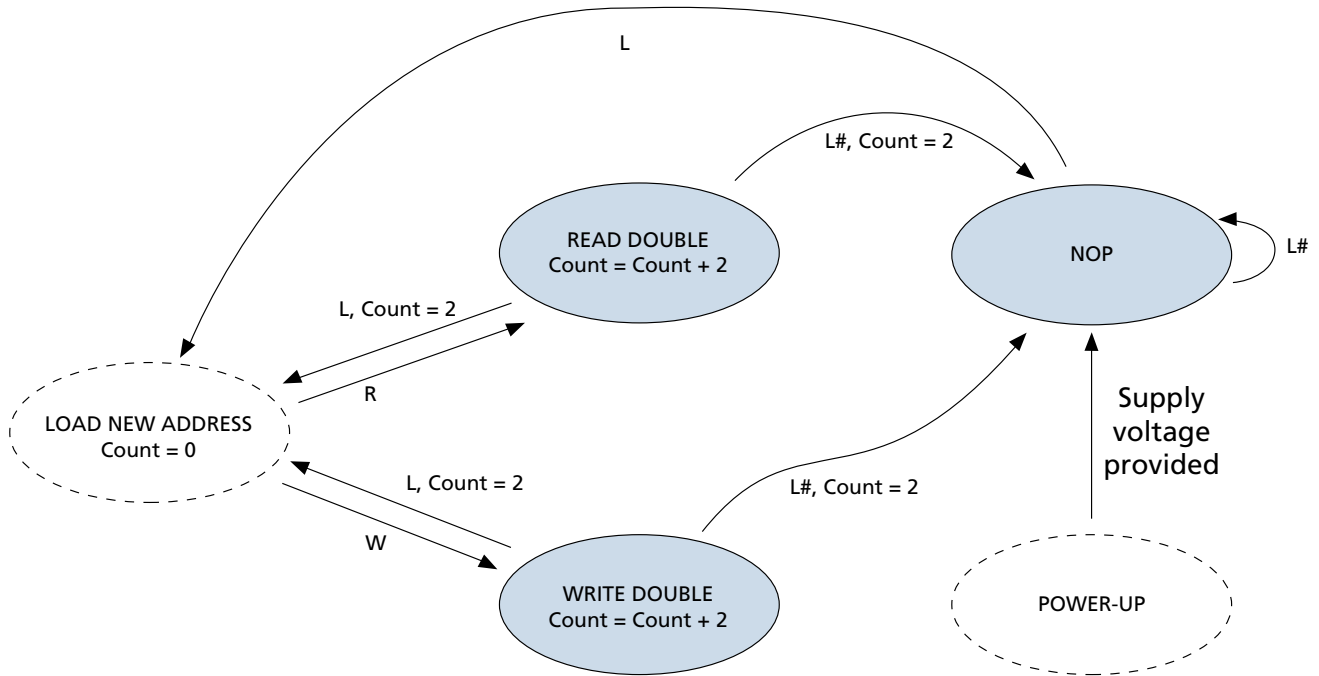

**NOTE:**

1. SA0 is internally advanced in accordance with the burst order table. Bus cycle is terminated after burst count = 2.
2. State transitions: L = (LD# = LOW); L# = (LD# = HIGH); R = (R/W# = HIGH); W = (R/W# = LOW).
3. State machine, control timing sequence is controlled by K.

**Table 6: Truth Table**

Notes 1-6

OPERATION	K	LD#	R/W#	D or Q	D or Q
WRITE Cycle: Load address, input write data on consecutive K and K# rising edges	L→H	L	L	DA(A0) at K(t)↑ Q = High-Z	DA(A0 + 1) at K#(t + 1)↑ Q = High-Z
READ Cycle: Load address, output data on consecutive C and C# rising edges	L→H	L	H	QA(A0) at C#(t)↑	QA(A0 + 1) at C(t + 1)↑
NOP: No operation	L→H	H	X	D = X Q = High-Z	D = X Q = High-Z
STANDBY: Clock stopped	Stopped	X	X	Previous State	Previous State

**Table 7: BYTE WRITE Operation**

Notes 7, 8

OPERATION	K	K#	BW0#	BW1#
WRITE D0:17 at K rising edge	L→H		0	0
WRITE D0:17 at K# rising edge		L→H	0	0
WRITE D0:8 at K rising edge	L→H		0	1
WRITE D0:8 at K# rising edge		L→H	0	1
WRITE D9:17 at K rising edge	L→H		1	0
WRITE D9:17 at K# rising edge		L→H	1	0
WRITE nothing at K rising edge	L→H		1	1
WRITE nothing at K# rising edge		L→H	1	1

**NOTE:**

1. X means "Don't Care." H means logic HIGH. L means logic LOW. ↑ means rising edge; ↓ means falling edge.
2. Data inputs are registered at K and K# rising edges. Data outputs are delivered at C and C# rising edges, except if C and C# are HIGH, then data outputs are delivered at K and K# rising edges.
3. LD# and R/W# must meet setup and hold times around the rising edge (LOW to HIGH) of K and are registered at the rising edge of K.
4. This device contains circuitry that will ensure the outputs will be in High-Z during power-up.
5. Refer to state diagram and timing diagrams for clarification.
6. It is recommended that K = K# = C = C# when clock is stopped. This is not essential but permits most rapid restart by overcoming transmission line charging symmetrically.
7. Assumes a WRITE cycle was initiated. BW0# and BW1# can be altered for any portion of the BURST WRITE operation provided that the setup and hold requirements are satisfied.
8. This table illustrates the operation for the x18 devices. The x36 device operation is similar, except for the addition of BW2# (controls D18:D26) and BW3# (controls D27:D35). The x8 device operation is similar, except that NW0# controls D0:D3, and NW1# controls D4:D7.



**Absolute Maximum Ratings**

Voltage on VDD Supply  
 Relative to VSS ..... -0.5V to +2.8V

Voltage on VDDQ Supply  
 Relative to VSS ..... -0.5V to +VDD

VIN ..... -0.5V to VDD +0.5V

Storage Temperature ..... -55°C to +125°C

Junction Temperature ..... +125°C

Short Circuit Output Current ..... ±70mA

Stresses greater than those listed under Absolute Maximum Ratings may cause permanent damage to the device. This is a stress rating only, and functional operation of the device at these or any other conditions above those indicated in the operational sections of this specification is not implied. Exposure to absolute maximum rating conditions for extended periods may affect reliability.

Maximum Junction Temperature depends upon package type, cycle time, loading, ambient temperature, and airflow.

**Table 8: DC Electrical Characteristics and Operating Conditions**

Notes appear following parameter tables on page 17; 0°C ≤ T<sub>A</sub> ≤ +70°C; VDD = 1.8V ±0.1V unless otherwise noted

DESCRIPTION	CONDITIONS	SYMBOL	MIN	MAX	UNITS	NOTES
Input High (Logic 1) Voltage		V <sub>IH(DC)</sub>	V <sub>REF</sub> + 0.1	VDDQ + 0.3	V	3, 4
Input Low (Logic 0) Voltage		V <sub>IL(DC)</sub>	-0.3	V <sub>REF</sub> - 0.1	V	3, 4
Clock Input Signal Voltage		V <sub>IN</sub>	-0.3	VDDQ + 0.3	V	3, 4
Input Leakage Current	0V ≤ V <sub>IN</sub> ≤ VDDQ	I <sub>LI</sub>	-5	5	µA	
Output Leakage Current	Output(s) disabled, 0V ≤ V <sub>IN</sub> ≤ VDDQ (Q)	I <sub>LO</sub>	-5	5	µA	
Output High Voltage	I <sub>OH</sub>   ≤ 0.1mA	V <sub>OH (LOW)</sub>	VDDQ - 0.2	VDDQ	V	3, 5, 6
	Note 1	V <sub>OH</sub>	VDDQ/2 - 0.12	VDDQ/2 + 0.12	V	3, 5, 6
Output Low Voltage	I <sub>OL</sub> ≤ 0.1mA	V <sub>OL (LOW)</sub>	V <sub>SS</sub>	0.2	V	3, 5, 6
	Note 2	V <sub>OL</sub>	VDDQ/2 - 0.12	VDDQ/2 + 0.12	V	3, 5, 6
Supply Voltage		VDD	1.7	1.9	V	3
Isolated Output Buffer Supply		VDDQ	1.4	VDD	V	3, 7
Reference Voltage		VREF	0.68	0.95	V	3

**Table 9: AC Electrical Characteristics and Operating Conditions**

Notes appear following parameter tables on page 17; 0°C ≤ T<sub>A</sub> ≤ +70°C; VDD = 1.8V ±0.1V unless otherwise noted

DESCRIPTION	CONDITIONS	SYMBOL	MIN	MAX	UNITS	NOTES
Input High (Logic 1) Voltage		V <sub>IH(AC)</sub>	V <sub>REF</sub> + 0.2	-	V	3, 4, 8
Input Low (Logic 0) Voltage		V <sub>IL(AC)</sub>	-	V <sub>REF</sub> - 0.2	V	3, 4, 8

**Table 10: I<sub>DD</sub> Operating Conditions and Maximum Limits**

 Notes appear following parameter tables on page 17; 0°C ≤ T<sub>A</sub> ≤ +70°C; V<sub>DD</sub> = 1.8V ±0.1V unless otherwise noted

DESCRIPTION	CONDITIONS	SYM	TYP	MAX						UNITS	NOTES
				-3	-3.3	-4	-5	-6	-7.5		
Operating Supply Current: DDR	All inputs ≤ V <sub>IL</sub> or ≥ V <sub>IH</sub> ; Cycle time ≥ <sup>t</sup> KHKH (MIN); Outputs open; x:1 ratio for READs to WRITEs; 50% address and data bits toggling on each clock cycle	I <sub>DD</sub> x8, x18 x36	TBD	525 710	475 640	400 545	330 445	280 380	235 310	mA	9, 10
Standby Supply Current: NOP	<sup>t</sup> KHKH = <sup>t</sup> KHKH (MIN); Device in NOP state; All addresses/data static	I <sub>SB1</sub> x8, x18 x36	TBD	255 265	235 240	200 210	170 180	150 160	125 135	mA	10, 11
Output Supply Current: DDR (Information only)	C <sub>L</sub> = 15pF	I <sub>DDQ</sub> x8 x18 x36	TBD	42 95 189	38 85 170	32 71 142	25 57 142	21 47 95	17 38 76	mA	12

**Table 11: Capacitance**

Note 13; notes appear following parameter tables on page 17

DESCRIPTION	CONDITIONS	SYMBOL	TYP	MAX	UNITS
Address/Control Input Capacitance	T <sub>A</sub> = 25°C; f = 1 MHz	C <sub>I</sub>	4.5	5.5	pF
Input, Output Capacitance (D, Q)		C <sub>O</sub>	6	7	pF
Clock Capacitance		C <sub>CK</sub>	5.5	6.5	pF

**Table 12: Thermal Resistance**

Note 13; notes appear following parameter tables on page 17

DESCRIPTION	CONDITIONS	SYMBOL	TYP	UNITS	NOTES
Junction to Ambient (Airflow of 1m/s)	Soldered on a 4.25 x 1.125 inch, 4-layer printed circuit board	θ <sub>JA</sub>	19.4	°C/W	14
Junction to Case (Top)		θ <sub>JC</sub>	1.0	°C/W	
Junction to Balls (Bottom)		θ <sub>JB</sub>	9.6	°C/W	15

**Table 13: AC Electrical Characteristics and Recommended Operating Conditions**

 Notes 16-19; 22; notes appear following parameter tables on page 17;  $0^{\circ}\text{C} \leq T_A \leq +70^{\circ}\text{C}$ ;  $T_J \leq +95^{\circ}\text{C}$ ;  $V_{DD} = 1.8\text{V} \pm 0.1\text{V}$ 

DESCRIPTION	SYM	-3		-3.3		-4		-5		-6		-7.5		UNITS	NOTES
		MIN	MAX	MIN	MAX	MIN	MAX	MIN	MAX	MIN	MAX	MIN	MAX		
<b>Clock</b>															
Clock cycle time (K, K#, C, C#)	$t_{KHKH}$	3.00	3.47	3.30	4.20	4.00	5.25	5.00	6.30	6.00	7.88	7.50	8.40	ns	20
Clock phase jitter (K, K#, C, C#)	$t_{KC\text{ var}}$		0.20		0.20		0.20		0.20		0.20		0.20	ns	21
Clock HIGH time (K, K#, C, C#)	$t_{KHKL}$	1.20		1.32		1.60		2.00		2.40		3.00		ns	
Clock LOW time (K, K#, C, C#)	$t_{KLKH}$	1.20		1.32		1.60		2.00		2.40		3.00		ns	
Clock to clock# (K $\uparrow$ →K# $\uparrow$ , C $\uparrow$ →C# $\uparrow$ ) at $t_{KHKH}$ minimum	$t_{KHK\#H}$	1.35		1.49		1.80		2.20		2.70		3.38		ns	
Clock# to clock (K# $\uparrow$ →K $\uparrow$ , C# $\uparrow$ →C $\uparrow$ ) at $t_{KHKH}$ minimum	$t_{K\#HKH}$	1.35		1.49		1.80		2.20		2.70		3.38		ns	
Clock to data clock (K $\uparrow$ →C $\uparrow$ , K# $\uparrow$ →C# $\uparrow$ )	$t_{KHCH}$	0.00	1.30	0.00	1.45	0.00	1.80	0.00	2.30	0.00	2.80	0.00	3.55	ns	
DLL lock time (K, C)	$t_{KC\text{ lock}}$	1,024		1,024		1,024		1,024		1,024		1,024		cycles	22
K static to DLL reset	$t_{KC\text{ reset}}$	30		30		30		30		30		30		ns	
<b>Output Times</b>															
C, C# HIGH to output valid	$t_{CHQV}$		0.45		0.45		0.45		0.45		0.50		0.50	ns	
C, C# HIGH to output hold	$t_{CHQX}$	-0.45		-0.45		-0.45		-0.45		-0.50		-0.50		ns	
C, C# HIGH to echo clock valid	$t_{CHCQ\text{ V}}$		0.45		0.45		0.45		0.45		0.50		0.50	ns	
C, C# HIGH to echo clock hold	$t_{CHCQ\text{ X}}$	-0.45		-0.45		-0.45		-0.45		-0.50		-0.50		ns	
CQ, CQ# HIGH to output valid	$t_{CQHQ\text{ V}}$		0.25		0.27		0.30		0.35		0.40		0.40	ns	23
CQ, CQ# HIGH to output hold	$t_{CQHQ\text{ X}}$	-0.25		-0.27		-0.30		-0.35		-0.40		-0.40		ns	23
C HIGH to output High-Z	$t_{CHQZ}$		0.45		0.45		0.45		0.45		0.50		0.50	ns	

**Table 13: AC Electrical Characteristics and Recommended Operating Conditions  
(Continued)**

DESCRIPTION	SYM	-3		-3.3		-4		-5		-6		-7.5		UNITS	NOTES
		MIN	MAX	MIN	MAX	MIN	MAX	MIN	MAX	MIN	MAX	MIN	MAX		
C HIGH to output Low-Z	t <sup>CHQX1</sup>	-0.45		-0.45		-0.45		-0.45		-0.50		-0.50		ns	
<b>Setup Times</b>															
Address valid to K rising edge	t <sup>AVKH</sup>	0.40		0.40		0.50		0.60		0.70		0.70		ns	16
Control inputs valid to K rising edge	t <sup>IVKH</sup>	0.40		0.40		0.50		0.60		0.70		0.70		ns	16
Data-in valid to K, K# rising edge	t <sup>DVKH</sup>	0.28		0.30		0.35		0.40		0.50		0.50		ns	16
<b>Hold Times</b>															
K rising edge to address hold	t <sup>KHAX</sup>	0.40		0.40		0.50		0.60		0.70		0.70		ns	16
K rising edge to control inputs hold	t <sup>KHIX</sup>	0.40		0.40		0.50		0.60		0.70		0.70		ns	16
K, K# rising edge to data-in hold	t <sup>KHDX</sup>	0.28		0.30		0.35		0.40		0.50		0.50		ns	16



## Notes

1. Outputs are impedance-controlled.  $|I_{OH}| = (V_{DDQ}/2)/(RQ/5)$  for values of  $175\Omega \leq RQ \leq 350\Omega$ .
2. Outputs are impedance-controlled.  $I_{OL} = (V_{DDQ}/2)/(RQ/5)$  for values of  $175\Omega \leq RQ \leq 350\Omega$ .
3. All voltages referenced to V<sub>SS</sub> (GND).
4. Overshoot:  $V_{IH(AC)} \leq V_{DD} + 0.7V$  for  $t \leq t_{KHKH}/2$   
Undershoot:  $V_{IL(AC)} \geq -0.5V$  for  $t \leq t_{KHKH}/2$   
Power-up:  $V_{IH} \leq V_{DDQ} + 0.3V$  and  $V_{DD} \leq 1.7V$  and  $V_{DDQ} \leq 1.4V$  for  $t \leq 200ms$   
During normal operation, V<sub>DDQ</sub> must not exceed V<sub>DD</sub>. LD# and R/W# signals may not have pulse widths less than  $t_{KHKL}$  (MIN) or operate at cycle rates less than  $t_{KHKH}$  (MIN).
5. AC load current is higher than the shown DC values. AC I/O curves are available upon request.
6. HSTL outputs meet JEDEC HSTL Class I and Class II standards.
7. The nominal value of V<sub>DDQ</sub> may be set within the range of 1.5V to 1.8V DC, and the variation of V<sub>DDQ</sub> must be limited to  $\pm 0.1V$  DC.
8. To maintain a valid level, the transitioning edge of the input must:
  - a. Sustain a constant slew rate from the current AC level through the target AC level,  $V_{IL(AC)}$  or  $V_{IH(AC)}$ .
  - b. Reach at least the target AC level.
  - c. After the AC target level is reached, continue to maintain at least the target DC level,  $V_{IL(DC)}$  or  $V_{IH(DC)}$ .
9. IDD is specified with no output current. IDD is linear with frequency. Typical value is measured at 6ns cycle time.
10. Typical values are measured at V<sub>DD</sub> = 1.8V, V<sub>DDQ</sub> = 1.5V, and temperature = 25°C.
11. NOP currents are valid when entering NOP after all pending READ and WRITE cycles are completed.
12. Average I/O current and power is provided for informational purposes only and is not tested. Calculation assumes that all outputs are loaded with C<sub>L</sub> (in farads), f = input clock frequency, half of outputs toggle at each transition (n = 18 for the x36), C<sub>O</sub> = 6pF, V<sub>DDQ</sub> = 1.5V and uses the equations: Average I/O Power as dissipated by the SRAM is:  $P = 0.5 \times n \times f \times V_{DDQ}^2 \times (C_L + 2C_O)$ . Average IDDQ =  $n \times f \times V_{DDQ} \times (C_L + C_O)$ .
13. This parameter is sampled.
14. Average thermal resistance between the die and the case top surface per MIL SPEC 883 Method 1012.1.
15. Junction temperature is a function of total device power dissipation and device mounting environment. Measured per SEMI G38-87.
16. This is a synchronous device. All addresses, data, and control lines must meet the specified setup and hold times for all latching clock edges.
17. Test conditions as specified with the output loading as shown in Figure 5 unless otherwise noted.
18. Control input signals may not be operated with pulse widths less than  $t_{KHKL}$  (MIN).
19. If C and C# are tied HIGH, then K and K# become the references for C and C# timing parameters.
20. The device will operate at clock frequencies slower than  $t_{KHKH}$  (MAX). See Micron Technical Note TN-54-02 for more information.
21. Clock phase jitter is the variance from clock rising edge to the next expected clock rising edge.
22. V<sub>DD</sub> slew rate must be less than 0.1V DC per 50ns for DLL lock retention. DLL lock time begins once V<sub>DD</sub> and input clock are stable.
23. Echo clock is tightly controlled to data valid/data hold. By design, there is a  $\pm 0.1ns$  variation from echo clock to data. The data sheet parameters reflect tester guardbands and test setup variations.

**AC Test Conditions**

Input pulse levels . . . . . 0.25V to 1.25V  
 Input rise and fall times . . . . . 0.7ns  
 Input timing reference levels . . . . . 0.75V  
 Output reference levels . . . . . V<sub>DDQ</sub>/2  
 Z<sub>Q</sub> for 50Ω impedance . . . . . 250Ω  
 Output load . . . . . See Figure 5

**Figure 5:  
Output Load Equivalent**

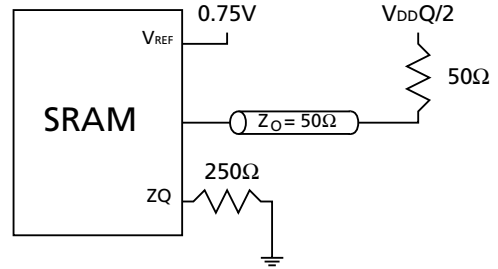

**Figure 6:  
READ/WRITE Timing**

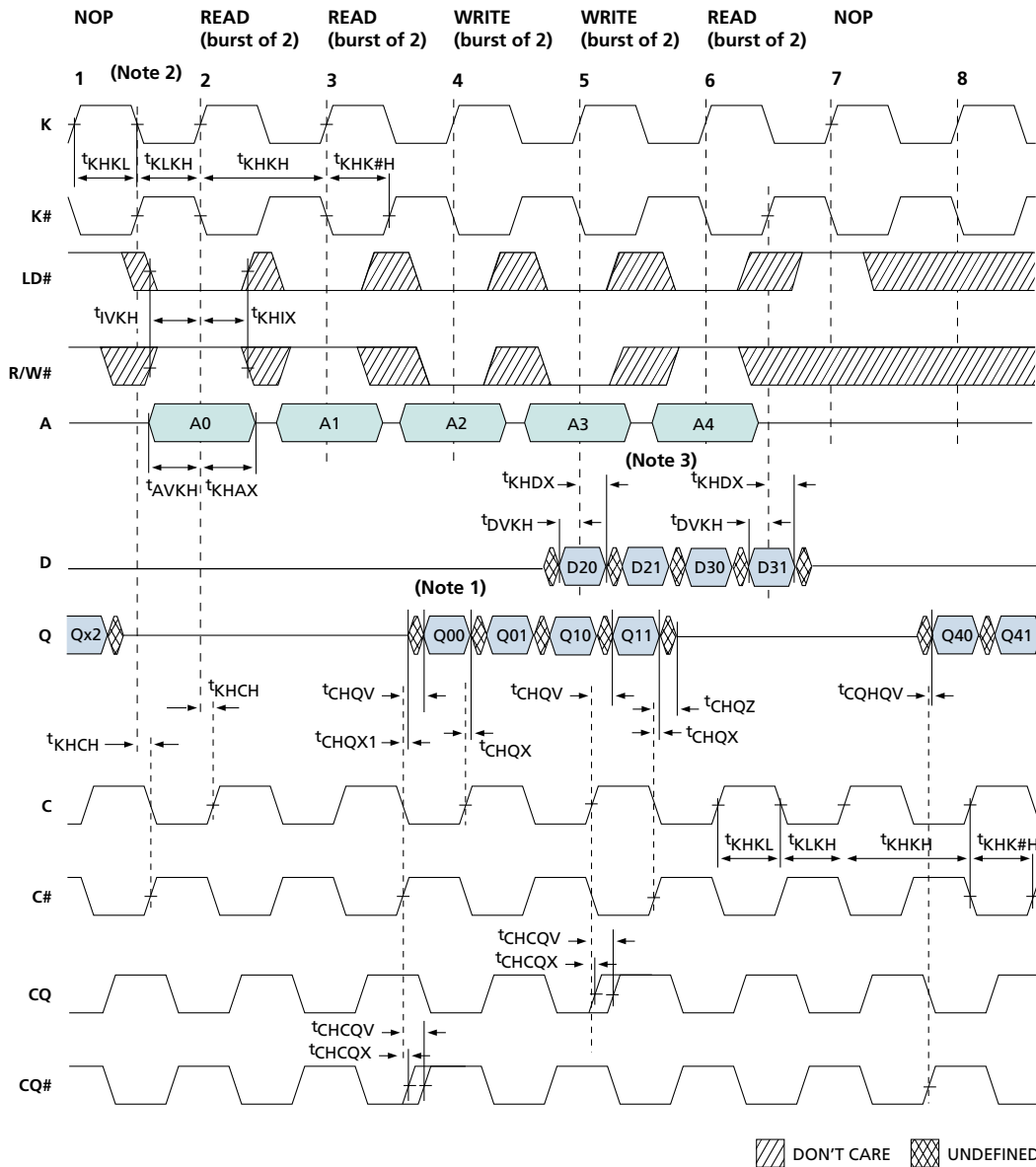

**NOTE:**

1. Q00 refers to output from address A0. Q01 refers to output from the next internal burst address following A0, i.e., A0 + 1.
2. Outputs are disabled (High-Z) one clock cycle after a NOP.
3. In this example, if address A3 = A4, then data Q40 = D30 and Q42 = D31. Write data is forwarded immediately as read results.

### IEEE 1149.1 Serial Boundary Scan (JTAG)

The SRAM incorporates a serial boundary scan test access port (TAP). This port operates in accordance with IEEE Standard 1149.1-1990 but does not have the set of functions required for full 1149.1 compliance. These functions from the IEEE specification are excluded because their inclusion places an added delay in the critical speed path of the SRAM. Note that the TAP controller functions in a manner that does not conflict with the operation of other devices using 1149.1 fully-compliant TAPs. The TAP operates using JEDEC-standard 1.8V I/O logic levels.

The SRAM contains a TAP controller, instruction register, boundary scan register, bypass register, and ID register.

### Disabling The JTAG Feature

It is possible to operate the SRAM without using the JTAG feature. To disable the TAP controller, TCK must be tied LOW (Vss) to prevent clocking of the device. TDI and TMS are internally pulled up and may be unconnected. Alternately, they may be connected to VDD through a pull-up resistor. TDO should be left unconnected. Upon power-up, the device will come up in a reset state, which will not interfere with the operation of the device.

**Figure 7:  
TAP Controller State Diagram**

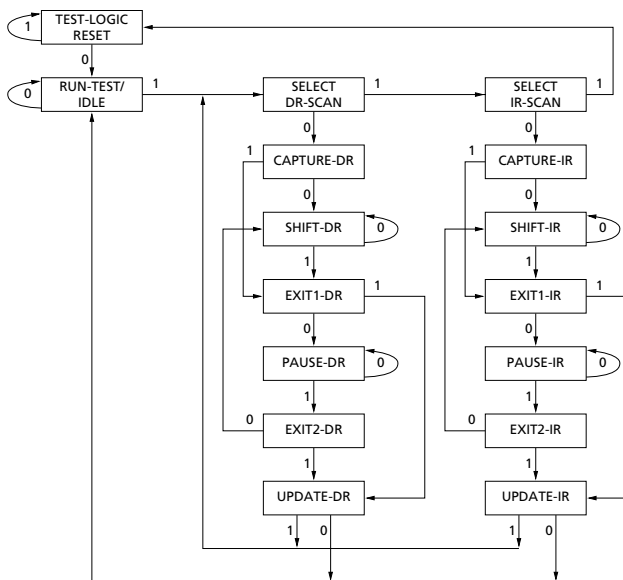

NOTE:

The 0/1 next to each state represents the value of TMS at the rising edge of TCK.

### Test Access Port (TAP)

#### Test Clock (TCK)

The test clock is used only with the TAP controller. All inputs are captured on the rising edge of TCK. All outputs are driven from the falling edge of TCK.

#### Test Mode Select (TMS)

The TMS input is used to give commands to the TAP controller and is sampled on the rising edge of TCK. It is allowable to leave this ball unconnected if the TAP is not used. The ball is pulled up internally, resulting in a logic HIGH level.

#### Test Data-in (TDI)

The TDI ball is used to serially input information into the registers and can be connected to the input of any of the registers. The register between TDI and TDO is chosen by the instruction that is loaded into the TAP instruction register. For information on loading the instruction register, see Figure 7. TDI is internally pulled up and can be unconnected if the TAP is unused in an application. TDI is connected to the most significant bit (MSB) of any register, as illustrated in Figure 8.

**Figure 8:  
TAP Controller Block Diagram**

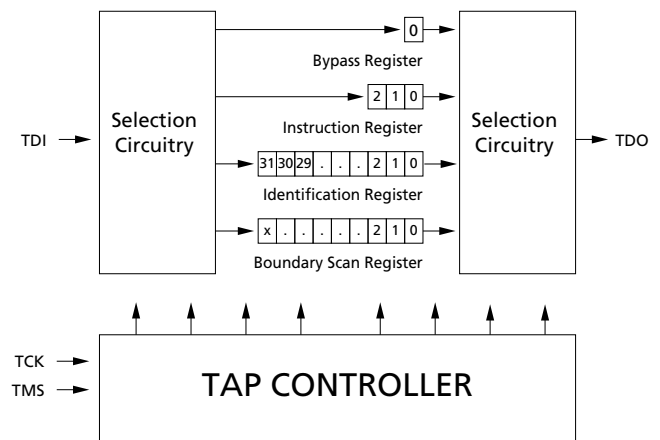

NOTE:

X = 106.

### **Test Data-out (TDO)**

The TDO output ball is used to serially clock data-out from the registers. The output is active depending upon the current state of the TAP state machine illustrated in Figure 8. The output changes on the falling edge of TCK. TDO is connected to the least significant bit (LSB) of any register, as depicted in Figure 8.

### **Performing a TAP RESET**

A RESET is performed by forcing TMS HIGH (V<sub>DD</sub>) for five rising edges of TCK. This RESET does not affect the operation of the SRAM and may be performed while the SRAM is operating.

At power-up, the TAP is reset internally to ensure that TDO comes up in a High-Z state.

### **TAP Registers**

Registers are connected between the TDI and TDO balls and allow data to be scanned into and out of the SRAM test circuitry. Only one register at a time can be selected through the instruction register. Data is serially loaded into the TDI ball on the rising edge of TCK. Data is output on the TDO ball on the falling edge of TCK.

### **Instruction Register**

Three-bit instructions can be serially loaded into the instruction register. This register is loaded when it is placed between the TDI and TDO balls, as shown in Figure 8. Upon power-up, the instruction register is loaded with the IDCODE instruction. It is also loaded with the IDCODE instruction if the controller is placed in a reset state, as described in the previous section.

When the TAP controller is in the Capture-IR state, the two LSBs are loaded with a binary “01” pattern to allow for fault isolation of the board-level serial test data path.

### **Bypass Register**

To save time when serially shifting data through registers, it is sometimes advantageous to skip certain chips. The bypass register is a single-bit register that can be placed between the TDI and TDO balls. This allows data to be shifted through the SRAM with minimal delay. The bypass register is set LOW (V<sub>SS</sub>) when the BYPASS instruction is executed.

### **Boundary Scan Register**

The boundary scan register is connected to all the input and bidirectional balls on the SRAM. Several no connect (NC) balls are also included in the scan register to reserve balls. The SRAM has a 107-bit-long register.

The boundary scan register is loaded with the contents of the RAM I/O ring when the TAP controller is in the Capture-DR state and is then placed between the TDI and TDO balls when the controller is moved to the Shift-DR state. The EXTEST, SAMPLE/PRELOAD, and SAMPLE Z instructions can be used to capture the contents of the I/O ring.

The Boundary Scan Order table shows the order in which the bits are connected. Each bit corresponds to one of the balls on the SRAM package. The MSB of the register is connected to TDI, and the LSB is connected to TDO.

### **Identification (ID) Register**

The ID register is loaded with a vendor-specific, 32-bit code during the Capture-DR state when the IDCODE command is loaded in the instruction register. The IDCODE is hardwired into the SRAM and can be shifted out when the TAP controller is in the Shift-DR state. The ID register has a vendor code and other information described in the Identification Register Definitions table.

### **TAP Instruction Set Overview**

Eight different instructions are possible with the three-bit instruction register. All combinations are listed in the Instruction Codes table. Three of these instructions are listed as RESERVED and should not be used. The other five instructions are described in detail below.

The TAP controller used in this SRAM is not fully compliant to the 1149.1 convention because some of the mandatory 1149.1 instructions are not fully implemented. The TAP controller cannot be used to load address, data or control signals into the SRAM and cannot preload the I/O buffers. The SRAM does not implement the 1149.1 commands EXTEST or INTEST or the PRELOAD portion of SAMPLE/PRELOAD; rather, it performs a capture of the I/O ring when these instructions are executed.

### **EXTEST**

EXTEST is a mandatory 1149.1 instruction which is to be executed whenever the instruction register is loaded with all 0s. EXTEST is not implemented in this SRAM TAP controller; therefore, this device is not 1149.1-compliant.

The TAP controller does not recognize an all-0 instruction. When an EXTEST instruction is loaded into the instruction register, the SRAM responds as if a SAMPLE/PRELOAD instruction has been loaded. EXTEST does not place the SRAM outputs (including CQ and CQ#) in a High-Z state.

### **IDCODE**

The IDCODE instruction causes a vendor-specific, 32-bit code to be loaded into the instruction register. It also places the instruction register between the TDI and TDO balls and allows the IDCODE to be shifted out of the device when the TAP controller enters the Shift-DR state. The IDCODE instruction is loaded into the instruction register upon power-up or whenever the TAP controller is given a test logic reset state.

### **SAMPLE Z**

The SAMPLE Z instruction causes the boundary scan register to be connected between the TDI and TDO balls when the TAP controller is in a Shift-DR state. It also places all SRAM outputs into a High-Z state.

### **SAMPLE/PRELOAD**

SAMPLE/PRELOAD is a 1149.1 mandatory instruction. The PRELOAD portion of this instruction is not implemented, so the device TAP controller is not fully 1149.1-compliant.

Note that since the PRELOAD part of the command is not implemented, putting the TAP into the Update-DR state while performing a SAMPLE/PRELOAD instruction will have the same effect as the Pause-DR command.

### **BYPASS**

When the BYPASS instruction is loaded in the instruction register and the TAP is placed in a Shift-DR state, the bypass register is placed between TDI and TDO. The advantage of the BYPASS instruction is that it shortens the boundary scan path when multiple devices are connected together on a board.

### **Reserved**

These instructions are not implemented but are reserved for future use. Do not use these instructions.

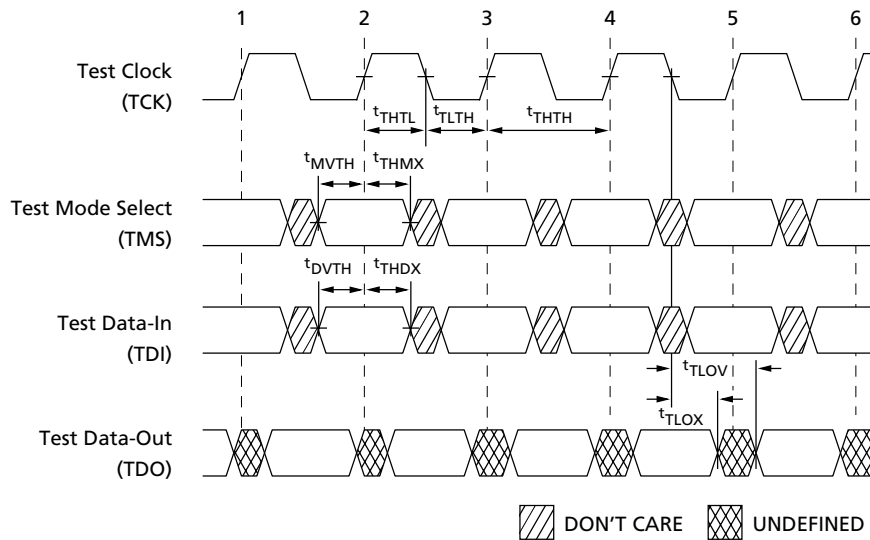
**Figure 9: TAP Timing**

**NOTE:**

Timing for SRAM inputs and outputs is congruent with TDI and TDO, respectively, as shown in Figure 9.

**Table 14: TAP AC Electrical Characteristics**

 Notes 1, 2; 0°C ≤ T<sub>A</sub> ≤ +70°C; V<sub>DD</sub> = 1.8V ±0.1V

DESCRIPTION	SYMBOL	MIN	MAX	UNITS
<b>Clock</b>				
Clock cycle time	t <sub>THTH</sub>	100		ns
Clock frequency	f <sub>TF</sub>		10	MHz
Clock HIGH time	t <sub>THTL</sub>	40		ns
Clock LOW time	t <sub>TLTH</sub>	40		ns
<b>Output Times</b>				
TCK LOW to TDO unknown	t <sub>TLOX</sub>	0		ns
TCK LOW to TDO valid	t <sub>TLOV</sub>		20	ns
TDI valid to TCK HIGH	t <sub>DVTH</sub>	10		ns
TCK HIGH to TDI invalid	t <sub>THDX</sub>	10		ns
<b>Setup Times</b>				
TMS setup	t <sub>MVTH</sub>	10		ns
Capture setup	t <sub>CS</sub>	10		ns
<b>Hold Times</b>				
TMS hold	t <sub>THMX</sub>	10		ns
Capture hold	t <sub>CH</sub>	10		ns

**NOTE:**

1. t<sub>CS</sub> and t<sub>CH</sub> refer to the setup and hold time requirements of latching data from the boundary scan register.
2. Test conditions are specified using the load in Figure 10.

### TAP AC Test Conditions

Input pulse levels . . . . . V<sub>SS</sub> to 1.8V  
 Input rise and fall times . . . . . 1ns  
 Input timing reference levels . . . . . 0.9V  
 Output reference levels . . . . . 0.9V  
 Test load termination supply voltage . . . . . 0.9V

**Figure 10:**  
**TAP AC Output Load Equivalent**

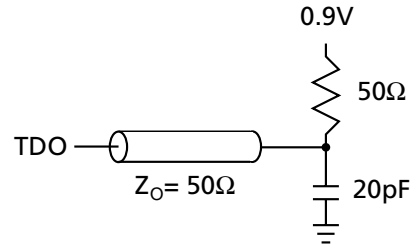

**Table 15: TAP DC Electrical Characteristics and Operating Conditions**

Note 2; 0°C ≤ T<sub>A</sub> ≤ +70°C; V<sub>DD</sub> = 1.8V ±0.1V unless otherwise noted

DESCRIPTION	CONDITIONS	SYMBOL	MIN	MAX	UNITS	NOTES
Input High (Logic 1) Voltage		V <sub>IH</sub>	1.3	V <sub>DD</sub> + 0.3	V	1, 2
Input Low (Logic 0) Voltage		V <sub>IL</sub>	-0.3	0.5	V	1, 2
Input Leakage Current	0V ≤ V <sub>IN</sub> ≤ V <sub>DD</sub>	I <sub>LI</sub>	-5.0	5.0	μA	2
Output Leakage Current	Output(s) disabled, 0V ≤ V <sub>IN</sub> ≤ V <sub>DD</sub>	I <sub>LO</sub>	-5.0	5.0	μA	2
Output Low Voltage	I <sub>OLC</sub> = 100μA	V <sub>OL1</sub>		0.2	V	1, 2
Output Low Voltage	I <sub>OLT</sub> = 2mA	V <sub>OL2</sub>		0.4	V	1, 2
Output High Voltage	I <sub>OHC</sub>   = 100μA	V <sub>OH1</sub>	1.6		V	1, 2
Output High Voltage	I <sub>OHT</sub>   = 2mA	V <sub>OH2</sub>	1.4		V	1, 2

**NOTE:**

1. All voltages referenced to V<sub>SS</sub> (GND).
2. This table defines DC values for TAP control and data balls only. The DQ SRAM balls used in JTAG operation will have the DC values as defined in Table 8, "DC Electrical Characteristics and Operating Conditions," on page 13.



**Table 16: Identification Register Definitions**

INSTRUCTION FIELD	ALL DEVICES	DESCRIPTION
REVISION NUMBER (31:29)	000	Revision number.
DEVICE ID (28:12)	00def0wx0t0q0b0s0	def = 010 for 36Mb density def = 001 for 18Mb density wx = 11 for x36 width wx = 10 for x18 width wx = 01 for x8 width t = 1 for DLL version t = 0 for non-DLL version q = 1 for QDR q = 0 for DDR b = 1 for 4-word burst b = 0 for 2-word burst s = 1 for separate I/O s = 0 for common I/O
MICRON JEDEC ID CODE (11:1)	00000101100	Allows unique identification of SRAM vendor.
ID Register Presence Indicator (0)	1	Indicates the presence of an ID register.

**Table 17: Scan Register Size**

REGISTER NAME	BIT SIZE
Instruction	3
Bypass	1
ID	32
Boundary Scan	107

**Table 18: Instruction Codes**

INSTRUCTION	CODE	DESCRIPTION
EXTEST	000	Captures I/O ring contents. Places the boundary scan register between TDI and TDO. This instruction is not 1149.1-compliant.
IDCODE	001	Loads the ID register with the vendor ID code and places the register between TDI and TDO. This operation does not affect SRAM operations.
SAMPLE Z	010	Captures I/O ring contents. Places the boundary scan register between TDI and TDO. Forces all SRAM output drivers to a High-Z state.
RESERVED	011	Do Not Use: This instruction is reserved for future use.
SAMPLE/ PRELOAD	100	Captures I/O ring contents. Places the boundary scan register between TDI and TDO. This instruction does not implement 1149.1 preload function and is therefore not 1149.1-compliant.
RESERVED	101	Do Not Use: This instruction is reserved for future use.
RESERVED	110	Do Not Use: This instruction is reserved for future use.
BYPASS	111	Places the bypass register between TDI and TDO. This operation does not affect SRAM operations.



**Table 19: Boundary Scan (Exit) Order**

BIT#	FBGA BALL
1	6R
2	6P
3	6N
4	7P
5	7N
6	7R
7	8R
8	8P
9	9R
10	11P
11	10P
12	10N
13	9P
14	10M
15	11N
16	9M
17	9N
18	11L
19	11M
20	9L
21	10L
22	11K
23	10K
24	9J
25	9K
26	10J
27	11J
28	11H
29	10G
30	9G
31	11F
32	11G
33	9F
34	10F
35	11E
36	10E

BIT#	FBGA BALL
37	10D
38	9E
39	10C
40	11D
41	9C
42	9D
43	11B
44	11C
45	9B
46	10B
47	11A
48	10A
49	9A
50	8B
51	7C
52	6C
53	8A
54	7A
55	7B
56	6B
57	6A
58	5B
59	5A
60	4A
61	5C
62	4B
63	3A
64	2A
65	1A
66	2B
67	3B
68	1C
69	1B
70	3D
71	3C
72	1D

BIT#	FBGA BALL
73	2C
74	3E
75	2D
76	2E
77	1E
78	2F
79	3F
80	1G
81	1F
82	3G
83	2G
84	1J
85	2J
86	3K
87	3J
88	2K
89	1K
90	2L
91	3L
92	1M
93	1L
94	3N
95	3M
96	1N
97	2M
98	3P
99	2N
100	2P
101	1P
102	3R
103	4R
104	4P
105	5P
106	5N
107	5R

**Figure 11:  
165-Ball FBGA**

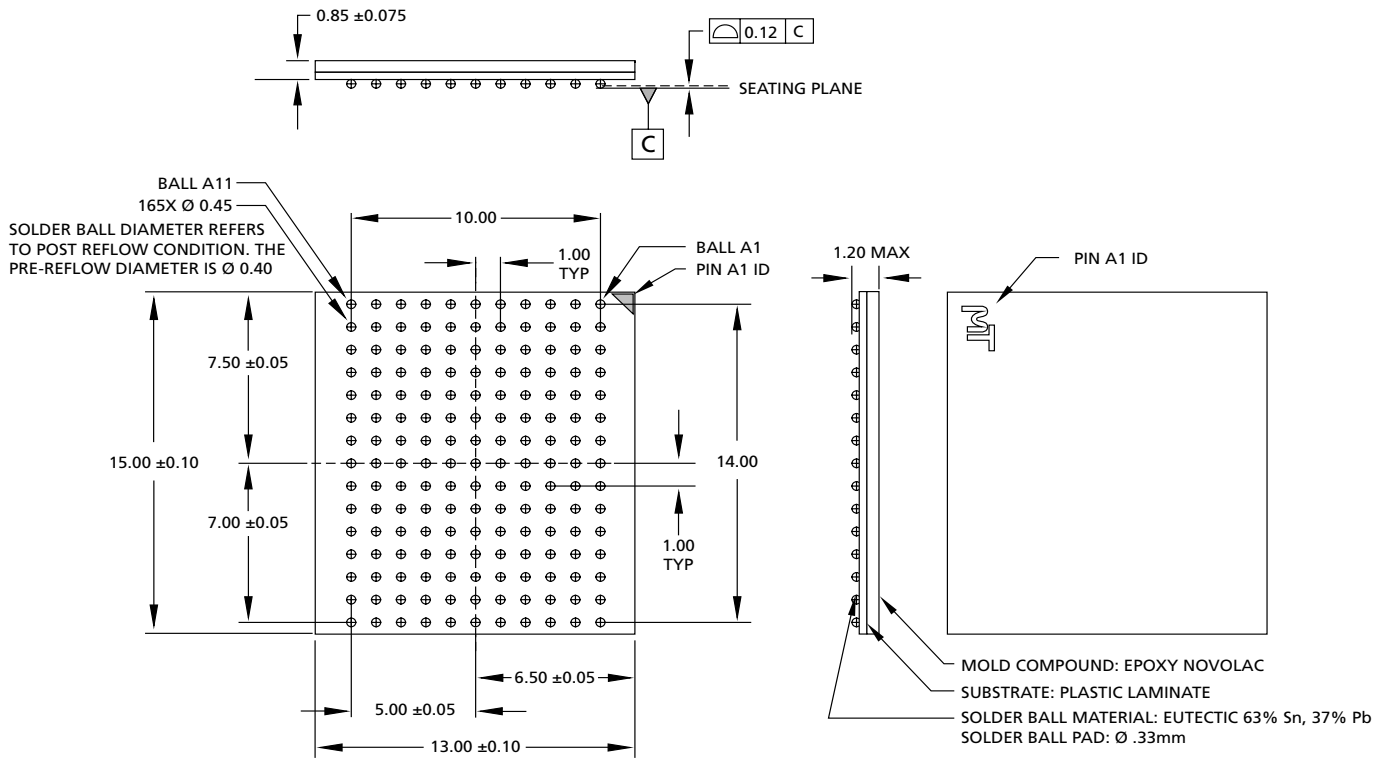

**NOTE:**

1. All dimensions are in millimeters.

**Data Sheet Designation**

**No Marking:** This data sheet contains minimum and maximum limits specified over the complete power supply and temperature range for production devices. Although considered final, these specifications are subject to change, as further product development and data characterization sometimes occur.



8000 S. Federal Way, P.O. Box 6, Boise, ID 83707-0006, Tel: 208-368-3900

E-mail: [prodmtg@micron.com](mailto:prodmtg@micron.com), Internet: <http://www.micron.com>, Customer Comment Line: 800-932-4992

Micron, the M logo, and the Micron logo are trademarks and/or service marks of of Micron Technology, Inc.

**Document Revision History**

Rev. H, Pub 3/03 .....	3/03
• Updated JTAG Section	
• Removed Preliminary Status	
Rev. G, Pub 2/03.....	2/03
• Added definitive notes to Figure 3	
• Added definitive note to Table 9	
• Added definitive note concerning bit# 64 to Table 19	
• Removed Errata specifications	
• Updated AC timing values with new codevelopment values	
• Updated JTAG description to reflect 1149.1 specification compliance with EXTEST feature	
• Added definitive note concerning SRAM (DQ) I/O balls used for JTAG DC values and timing	
• Changed process information in header to die revision indicator	
• Updated Thermal Resistance Values to Table 12: C <sub>I</sub> = 4.5 TYP; 5.5 MAX C <sub>O</sub> = 6 TYP; 7 MAX C <sub>CK</sub> = 5.5 TYP; 6.5 MAX	
• Updated Thermal Resistance values to Table 12: J <sub>A</sub> = 19.4 TYP J <sub>C</sub> = 1.0 TYP J <sub>B</sub> = 9.6 TYP	
• Added T <sub>J</sub> ≤ +95°C to Table 13	
• Modified Figure 2 regarding depth, configuration, and byte controls	
• Added definitive notes regarding I/O behavior during JTAG operation	
• Added definitive notes regarding IDD test conditions for read to write ratio	
• Removed note regarding AC derating information for full I/O range	
• Remove references to JTAG scan chain logic levels being at logic zero for NC pins in Tables 5 and 19	
• Revised ball description for NC balls: These balls are internally connected to the die, but have no function and may be left not connected to the board to minimize ball count.	
Rev. 6, Pub 9/02 .....	9/02
• Reverted data sheet to PRELIMINARY designation	
Rev. 5, Pub. 9/02, ADVANCE .....	9/02
• Added new Output Times values	
• Added Errata to back of data sheet	
• emoved ADVANCE designation	
• Removed T <sub>J</sub> references	
Rev. 4, Pub. 8/02, ADVANCE .....	8/02
• Updated format	
Rev. 3, Pub. 12/01, ADVANCE .....	12/01
• Changed AC timing	
Rev. 2, Pub. 11/01, ADVANCE .....	11/01
• New ADVANCE data sheet	