

BGA461

Silicon Germanium GPS Low Noise Amplifier

RF & Protection Devices



Edition 2009-01-22

**Published by
Infineon Technologies AG
81726 München, Germany**

**© Infineon Technologies AG 2009.
All Rights Reserved.**

Legal Disclaimer

The information given in this document shall in no event be regarded as a guarantee of conditions or characteristics ("Beschaffenhheitsgarantie"). With respect to any examples or hints given herein, any typical values stated herein and/or any information regarding the application of the device, Infineon Technologies hereby disclaims any and all warranties and liabilities of any kind, including without limitation warranties of non-infringement of intellectual property rights of any third party.

Information

For further information on technology, delivery terms and conditions and prices please contact your nearest Infineon Technologies Office (www.infineon.com).

Warnings

Due to technical requirements components may contain dangerous substances. For information on the types in question please contact your nearest Infineon Technologies Office.

Infineon Technologies Components may only be used in life-support devices or systems with the express written approval of Infineon Technologies, if a failure of such components can reasonably be expected to cause the failure of that life-support device or system, or to affect the safety or effectiveness of that device or system. Life support devices or systems are intended to be implanted in the human body, or to support and/or maintain and sustain and/or protect human life. If they fail, it is reasonable to assume that the health of the user or other persons may be endangered.

BGA461**Revision History: 2009-01-22, Rev.1.1 (Preliminary Data Sheet)****Previous Version: 2008-06-27, Rev.1.0 (Target Data Sheet)**

Page	Subjects (major changes since last revision)
all	Preliminary data sheet
5	Marking code defined: BU
5	Thermal resistance and maximum rating for total power dissipation corrected
6	Typical values for insertion power gain, noise figure and input return loss adjusted, IIP3 specified
7	Application information updated

1 Silicon Germanium GPS Low Noise Amplifier

Features

- Optimized for 1575 MHz Operation
- High gain: 19.5 dB
- Low Noise Figure: 1.1 dB
- Supply voltage: 2.4 V to 3.2 V
- 4mA current consumption
- Power off function
- 1 kV HBM ESD protection at all pins
- B7HFM Silicon Germanium technology
- RF output internally matched to 50 Ω
- Low external component count
- Tiny TSLP-7-4 leadless package
- Moisture sensitivity level: MSL 1
- Pb-free (RoHS compliant) package

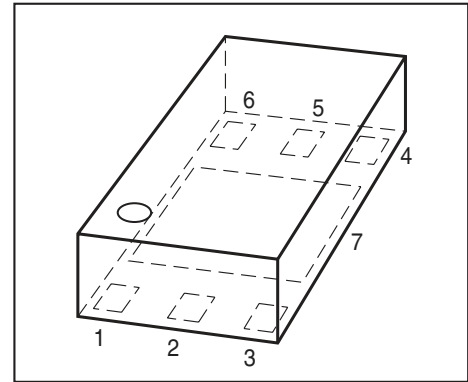

TSLP-7-4



Application

- 1575 MHz GPS, Galileo, GPS phone

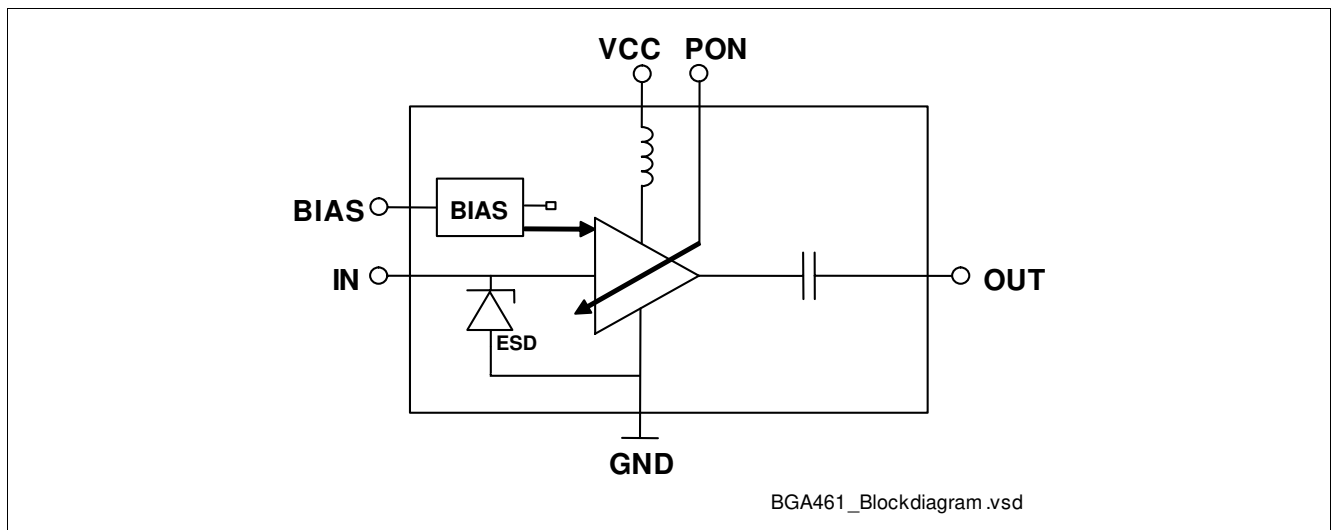

Figure 1 Blockdiagram

2 Description

The BGA461 is a front-end low noise amplifier for Global Positioning System (GPS) applications. The LNA provides 19.5 dB gain and 1.1 dB noise figure at a current consumption of 4 mA in the application configuration described in [Chapter 4](#). The BGA461 is based upon Infineon Technologies' B7HFM Silicon Germanium technology. It operates over a 2.4 V to 3.2 V supply range.

Type	Package	Marking
BGA461	TSLP-7-4	BU

Pin Definition and Function
Table 1 Pin Definition and Function

Pin No.	Symbol	Function
1	IN	LNA RF input
2	BIAS	DC bias
3	n.c.	not used
4	PON	Power on control
5	VCC	DC Supply
6	OUT	LNA RF output
7	GND	DC & RF ground

Maximum Ratings
Table 2 Maximum Ratings

Parameter ¹⁾	Symbol	Value	Unit
Voltage at pin VCC	V_{CC}	-0.3 ... 3.6	V
Voltage at pin IN	V_{IN}	-0.3 ... 0.9	V
Voltage at pin BIAS	V_{BIAS}	-0.3 ... 0.9	V
Voltage at pin OUT	V_{OUT}	-0.3 ... $V_{CC} + 0.3$	V
Voltage at pin PON	V_{PON}	-0.3 ... $V_{CC} + 0.3$	V
Current into pin VCC	I_{CC}	10	mA
RF input power	P_{IN}	10	dBm
Total power dissipation, $T_S < 139\text{ °C}^2)$	P_{tot}	90	mW
Junction temperature	T_J	150	°C
Ambient temperature range	T_A	-30 ... 85	°C
Storage temperature range	T_{STG}	-65 ... 150	°C
ESD capability all pins (HBM: JESD22A-114)	V_{ESD}	1000	V

1) All voltages refer to GND-Node.

2) T_S is measured on the ground lead at the soldering point

Thermal resistance
Table 3 Thermal resistance

Parameter	Symbol	Value	Unit
Junction - soldering point ¹⁾	R_{thJS}	125	K/W

1) For calculation of R_{thJA} please refer to Application Note Thermal Resistance

3 Electrical Characteristics

Table 4 Electrical Characteristics¹⁾: $T_A = 25\text{ °C}$, $V_{CC} = 2.8\text{ V}$, $V_{PON,ON} = 2.8\text{ V}$, $V_{PON,OFF} = 0\text{ V}$, $f = 1575\text{ MHz}$

Parameter	Symbol	Values			Unit	Note / Test Condition
		Min.	Typ.	Max.		
Supply voltage	V_{CC}	2.4	2.8	3.2	V	
Supply current	I_{CC}	-	4.0	-	mA	ON-mode
		-	0.2	3	μA	OFF-mode
Gain switch control voltage	V_{pon}	1.5	-	3.2	V	ON-mode
		0	-	0.5	V	OFF-mode
Gain switch control current	I_{pon}	-	1.5	3	μA	ON-mode
		-	0	1	μA	OFF-mode
Insertion power gain	$ S_{21} ^2$	-	19.5	-	dB	High-gain Mode
Noise figure ²⁾	NF	-	1.1	-	dB	$Z_S = 50\ \Omega$
Input return loss	RL_{in}	-	11	-	dB	
Output return loss	RL_{out}	-	>12	-	dB	
Reverse isolation	$1/ S_{12} ^2$	-	35	-	dB	
Power gain settling time ³⁾	t_S	-	20	-	μs	OFF- to ON-mode
		-	50	-	μs	ON- to OFF-mode
Inband input 3rd order intercept point ⁴⁾	IIP_3	-	-11	-	dBm	$f_1 = 1575\text{ MHz}$ $f_2 = f_1 \pm 1\text{ MHz}$
Inband input 1 dB compression point	IP_{1dB}	-	-14	-	dBm	
Stability	k	-	> 1.5	-		$f = 20\text{ MHz} \dots 10\text{ GHz}$

1) Measured on BGA461 application board described in [Chapter 4](#), including PCB losses (unless noted otherwise)

2) PCB transmission line- and connector losses subtracted

3) To within 1 dB of the final gain OFF- to ON-mode; to within 3 dB of the final gain ON- to OFF-mode

4) Input Power = -40 dBm for each tone

4 Application Information

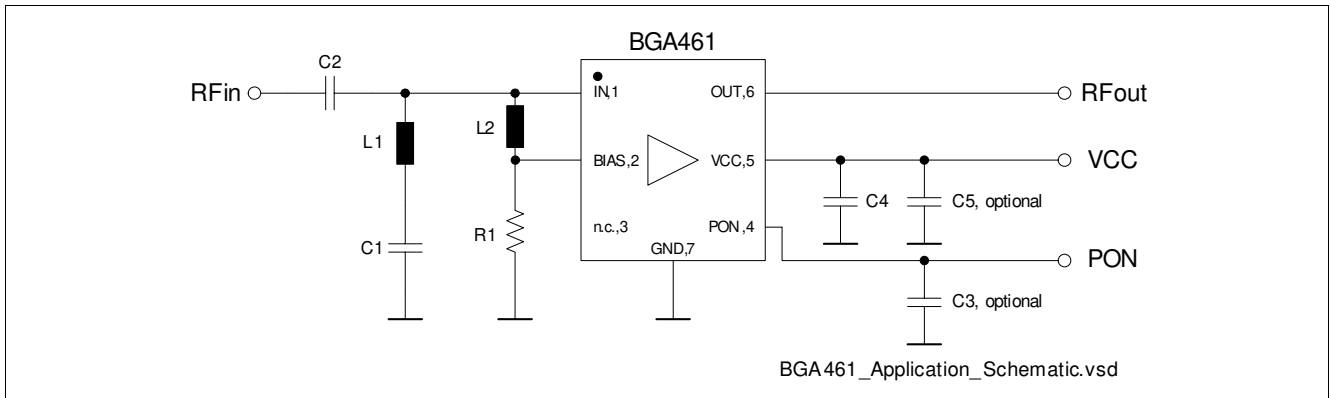

Figure 2 Application Schematic BGA461

Table 5 Bill of Materials

Name	Value	Package	Manufacturer	Function
C1	10 nF	0402	Various	LF trap
C2	2.7 pF	0402	Various	DC block and input matching
C3	10 pF	0402	Various	(optional) Control voltage filtering
C4	100 pF	0402	Various	Supply filtering
C5	2.2 nF	0402	Various	(optional) Supply filtering
L1	2.2 nH LQG15H series	0402	Murata	LF trap & input matching
L2	33 nH LQG15H series	0402	Murata	Biasing
R1	4.7 kΩ	0402	Various	Current adjustment
N1	BGA461	TSLP-7-4	Infineon	SiGe LNA

A list of all application notes is available at <http://www.infineon.com/cms/en/product>.

5 Package Information

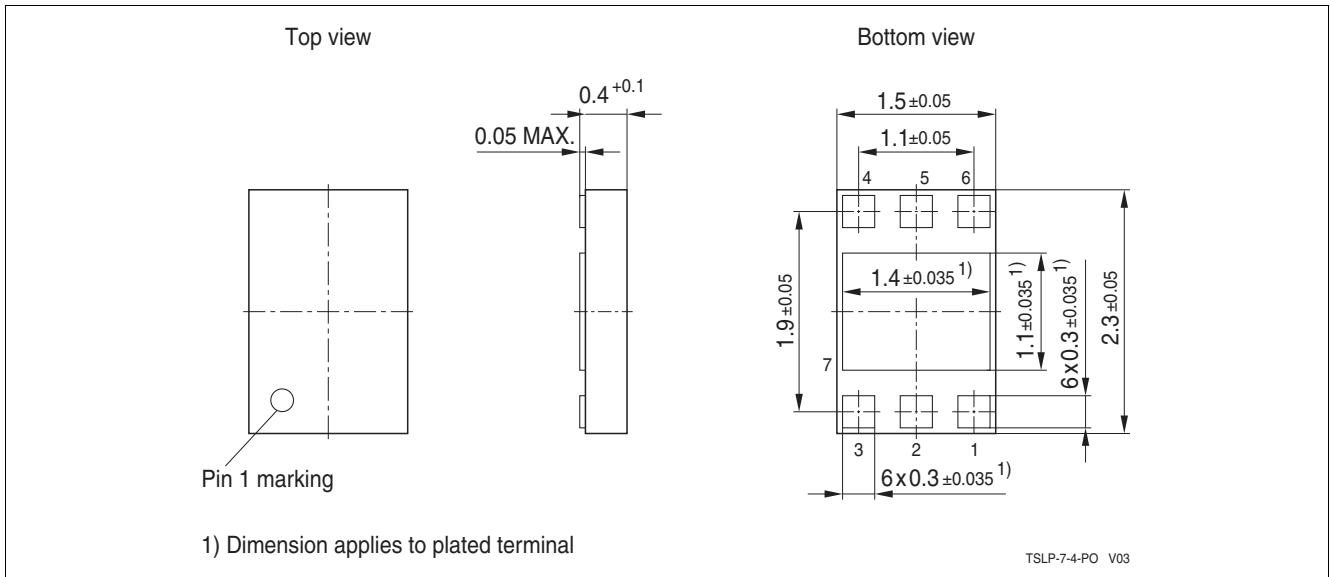

Figure 3 Package Dimensions for TSLP-7-4 (top, side and bottom view)

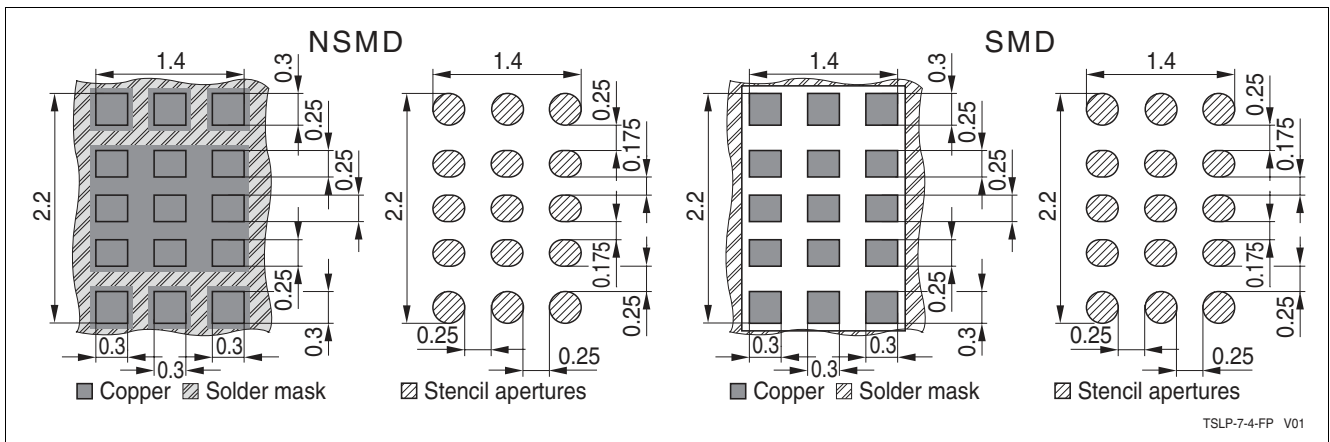

Figure 4 Footprint TSLP-7-4

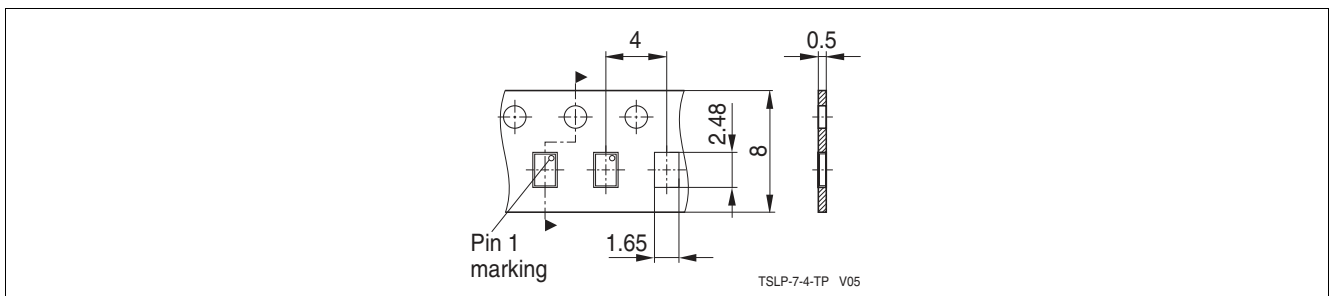

Figure 5 Tape & Reel Dimensions (Ø reel 330, pieces/reel 7500)