

DATA CONTAINED IN THIS DOCUMENT IS PROPRIETARY TO TROMPETER ELECTRONICS, INC. AND SHALL NOT BE DISCLOSED, COPIED OR USED FOR PROCUREMENT OR MANUFACTURE WITHOUT EXPRESS WRITTEN PERMISSION.

**REVISIONS**

REV	DESCRIPTIONS	DATE	APPROVED
F	REVISED PER ECO 15468	6/19/84	[Signature]

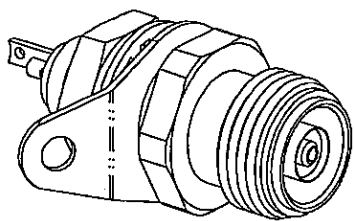

SCALE 2/1

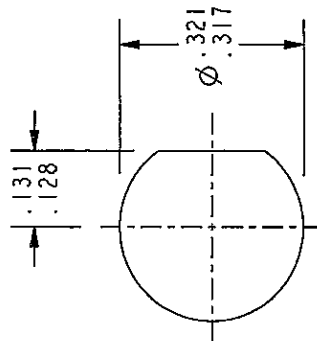

RECOMMENDED  
PANEL CUTOUT  
SCALE 3/1

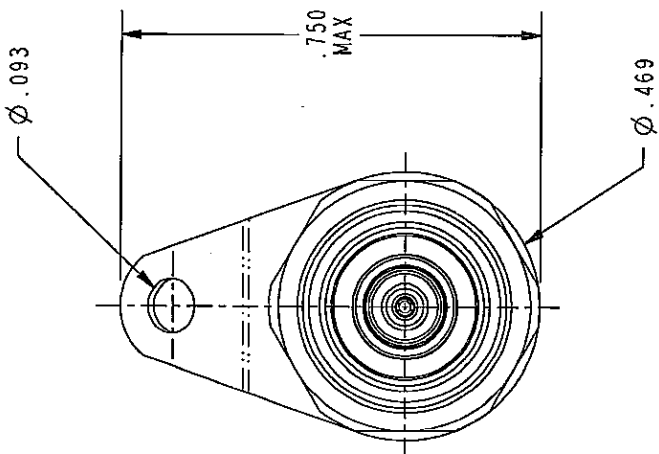
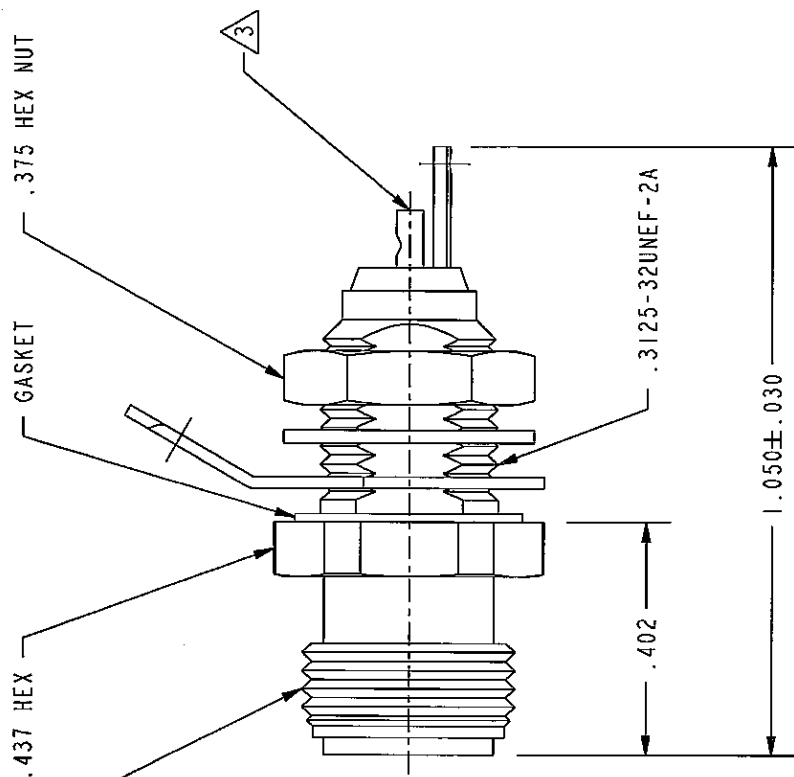

**RED INDICATES ORIGINAL**

4. SUBMINIATURE TRIAXIAL SOLDER POT BULKHEAD RECEPTACLE (TTM)

△ SOLDER POT ACCEPTS  $\phi .034$  CONDUCTOR

2. MAXIMUM PANEL THICKNESS: .187

1. FINISH: TFS-1A (NICKEL)

NOTES: UNLESS OTHERWISE SPECIFIED.

		TITLE:	
INTERPRET DRAWING PER MIL-STD-100. DIMENSIONS ARE IN INCHES AND INCLUDE FINISH THICKNESS UNLESS OTHERWISE SPECIFIED.		TOL: UNLESS SPECIFIED: .XX ± .02 .XXX ± .010 ANGLE ± 1°	
DWN L. M. 5-20-04	MATERIAL:	DO NOT SCALE DWG	SCALE 3/1
CHK [Signature] 6-3-04	FINISH:	DATE 8-8-80	SHEET 1C
QTY [Signature] 6/19/84	DRAWING NO.	SIZE A	CAGE CODE
MFG [Signature] 6/19/84	3-0046	14949	REV. F
APPROV [Signature] 6/19/84	PROJECT NO.	3-0046	DATE
NEXT ASSY	3-0046	8-8-80	1C