

BBT3420

Quad 2.488-3.1875Gbps/Channel Transceiver

FN7481

Rev 1.00

September 14, 2005

1 Features

- Four channels of transmitter and receiver with serial data transfer rates of 2.488-3.1875Gbps/channel with full rate and half-rate operations
- Up to 12.75Gbps data rate at full duplex
- User-controlled dual-speed operation (per channel) 2.488-3.1875Gbps or 1.244-1.59Gbps
- IEEE 802.3ae-2002 10 GE and 10 GFC compliant
 - XAUI, XGMII, and MDC/MDIO interfaces
- XGMII format 10-bit parallel input/output data
 - Supports HSTL 1.8V and 2.5V SSTL_2
- Extensive configuration via 802.3-compliant MDC/MDIO serial interface
- 8bit/10bit Encoding/Decoding per channel with selectable parallel input/output data sizes
 - Support optional 8b/10b encoder/decoder bypass operation
- Integrated Equalization and Pre-emphasis
- De-skewing and channel-to-channel alignment options
- Low power, 250mW per channel typical
- Meets jitter requirements with significant margin
- Comma detection and synchronization, byte alignment
- Tx/Rx rate matching via IDLE insertion/deletion
- Receive signal detect and 16 levels of transmission medium equalization
- CML transmit outputs with four levels of pre-emphasis
- Loopback
 - Per-channel serial Tx-to-Rx and Rx-to-Tx parallel internal loopback modes
- Single-ended/differential input Reference clock
- Double Data-Rate (DDR) mode, also optional SDR (Single Data Rate) on transmitter
- Support both source-centered and source-simultaneous clocking
- Long Run Length (512 bit) frequency lock ideal for proprietary encoding schemes Transmit byte clock schemes
 - One Transmit Byte Clock (TBC) for each channel, or one TBC for all four channels
- Received clock schemes
 - Receive data aligned to local reference clock, to recovered clock for each channel, or to recovered clock for Channel A only
- Supports Built-In Self Test (BIST) and IEEE 1149.1 JTAG
- On-chip 25Ω series output terminations (XGMII side)
- Standard 0.18μm 1.8V CMOS technology
- 3.3V tolerant I/O

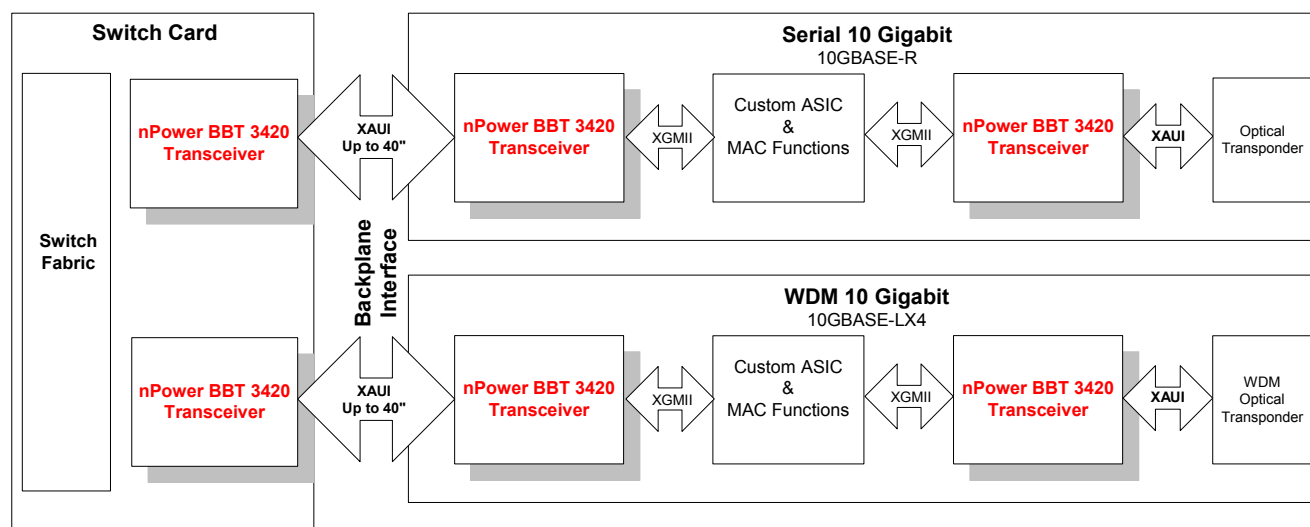

FIGURE 1-1. EXAMPLE BACKPLANE AND LINE CARD APPLICATIONS

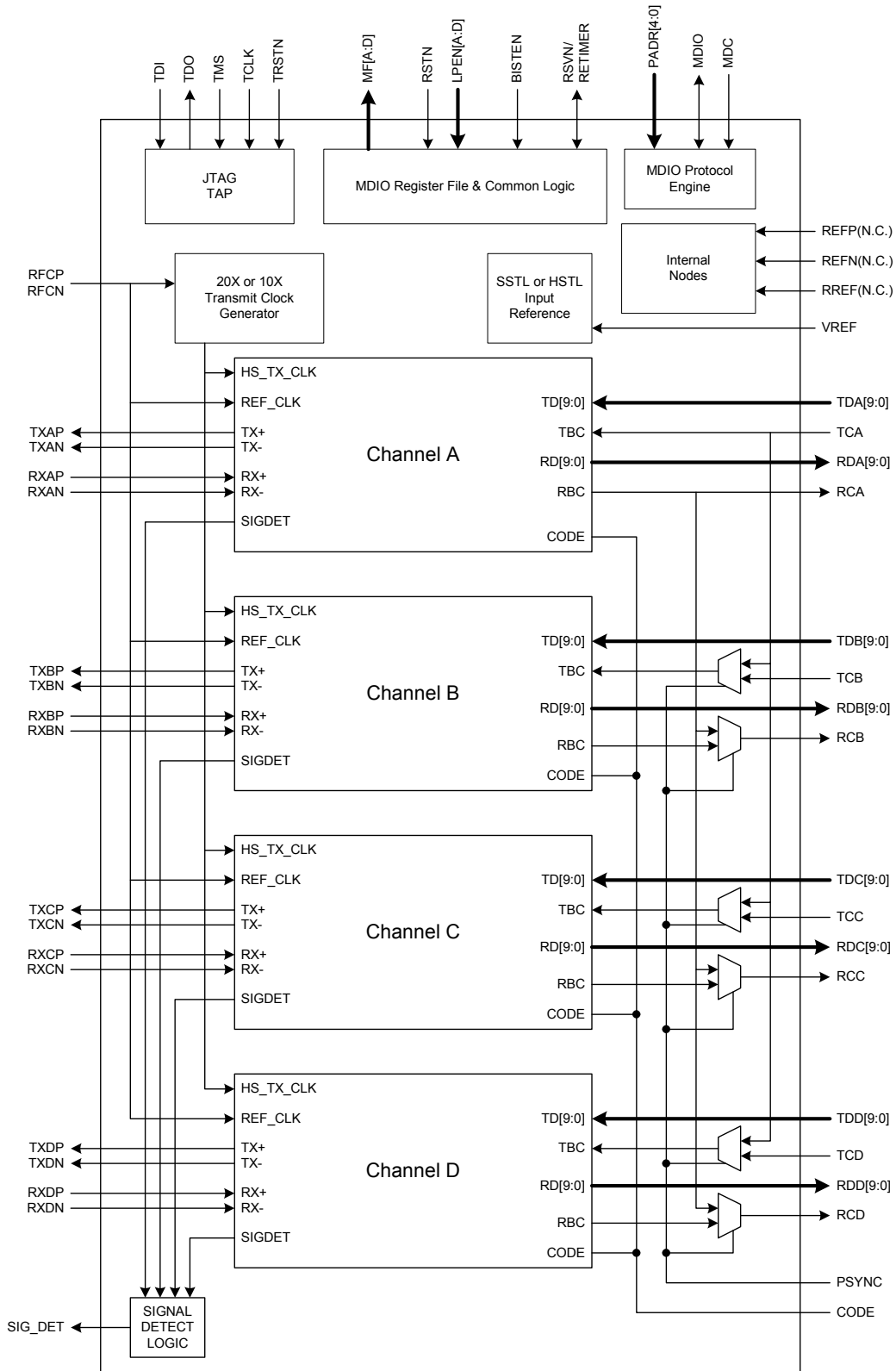

FIGURE 1-2. BBT3420 BLOCK DIAGRAM

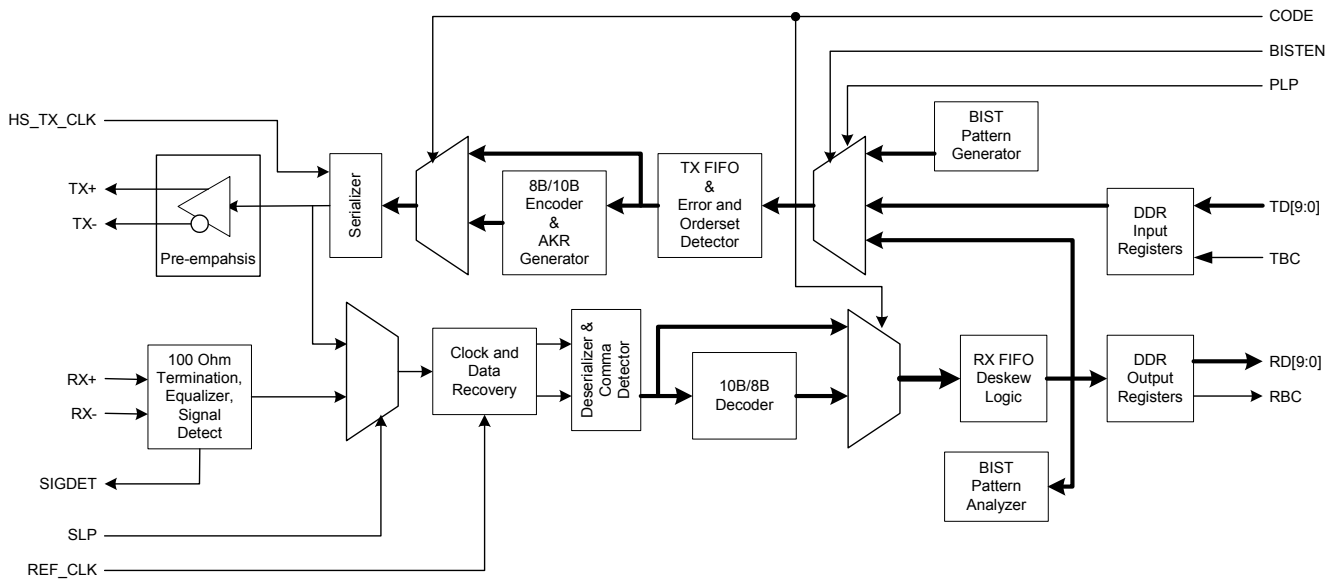

FIGURE 1-3. FUNCTIONAL BLOCK DIAGRAM OF A SINGLE CHANNEL

2 General Description

The BBT3420 is a quad 8-bit/10-bit parallel-to-serial and serial-to-parallel transceiver device ideal for high-bandwidth interconnection between line cards, serial backplanes, or optical modules, over interconnect media such as Printed Circuit Board (PCB) FR-4 traces or copper cables.

Each independent transceiver channel in BBT3420 is capable of operating at 2.488-3.1875Gbps at full-rate, and 1.244-1.59375Gbps at half-rate. The four on-chip transceivers shown in Figure 1-2 can also be configured as a single 10 Gigabit Attachment Unit Interface (XAUI), for both 10G Ethernet and 10G Fiber Channel or proprietary backplane interfaces, providing up to 12.75Gbps of data throughput at full duplex. The BBT3420 also supports the 10 Gigabit Media Independent Interface (XGMII) on the parallel interfaces. The device can be used as an XGMII Extended Sublayer (XGXS) device to support longer PCB traces between optical transceiver modules and switch fabrics, as shown in Figure 1-1.

As shown in Figure 1-3, each transceiver channel in BBT3420 contains a serializer, a deserializer, an 8b/10b encoder and decoder, as well as elastic buffers that provide the interface for serial data transmission and data recovery. Both the receive equalization and the transmit pre-emphasis are provided on each of the channels to maximize performance. In addition, a programmable receive FIFO in each channel aligns all incoming serial data to the local clock domain, adding or removing IDLE sequences as needed. This in return will eliminate the need for multiple clock domains for the interfaced ASIC device to the transceiver.

Each transceiver channel can also be configured to operate as a non-encoded 10-bit transceiver, allowing long strings of consecutive 1's or 0's (up to 512 bits). This feature enables the BBT3420 to accommodate proprietary encoded data links.

On each channel, the transmitter accepts up to 10-bit wide parallel SSTL_2 or HSTL Class I/I/O (Figure 2-1) data, which is then serialized into high-speed NRZ (Non-Return to Zero) serial streams. The effective serial output impedance is nominally 150Ω differential.

The BBT3420 transceiver can be configured via pins and through the Management Data Input/Output (MDIO) interface specified in IEEE 802.3 Clause 22 or Clause 45. The device supports both the 5-bit PHY address for Clause 22 and the 5-bit port address for Clause 45. The four device addresses for Clause 45 are user selectable. The device also supports the Built-in Self Test (BIST) and IEEE 1149.1 (JTAG) for self-test purposes including serial and parallel loopback under either external pin or MDIO control, and Pseudo Random Bit Sequence (PRBS) generation and verification.

The BBT3420 is assembled in a 289-pin 19mm x 19mm HSBGA package. The device can operate with a single 1.8V supply and dissipates only 250mW per channel.

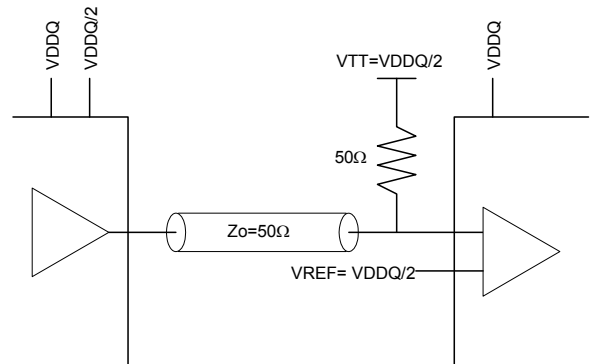

FIGURE 2-1. SSTL_2/HSTL CLASS I I/O

3.0 Detailed Functional Description

3.1 Transmit Parallel Input Modes

The parallel side of each of the channels in BBT3420 may operate in either a 10-bit mode or a XGMII 9-bit mode. The parallel input mode selection is controlled by the CODE pin (Table 4-6) and the CODECENA bit in the MDIO register at address 11'h in Clause 22 format (Table 3-16) and/or C000'h in Clause 45 format (Table 3-32). In order to program the device for XGMII 9-bit mode, the CODE pin should be set HIGH and the CODECENA bit set to 1'b. For the 10-bit Mode setting, either the CODE pin should be set to LOW or the CODECENA bit should be set to 0'b.

3.1.1 10-BIT MODE

In the 10-bit mode the 8b/10b Codec is disabled, and the externally encoded data are latched in the DDR input registers in increments of 10 bits. In this case, the user is responsible for generating and applying the proper input in the form of ordered sets, data, and correct 'comma' group signals, to ensure data coherence. The LSB (TDX[0]) is shifted out first on the serial side, and the MSB (TDX[9]) is shifted out last.

3.1.2 XGMII 9-BIT (8 BITS PLUS K CONTROL BIT) MODE

In the XGMII 9-bit mode, the unencoded data are latched in the DDR input registers in 9 bits at a time. The lower 8 bits (TD[A..D][7:0]) are byte-wide data or control values, and the 9th bit (TD[A..D][8]) is the "K" bit used to select special control characters for link management. In this mode, the 10th bit (TD[A..D][9]) is used for disparity error or code violation. The 8b/10b Codec is enabled, and converts the data and the valid control values.

The XGMII IDLE Code Register (Clause 22 Address 1B'h or Clause 45 Address C003'h) controls the data pattern that

represents an IDLE character. The default value of this register is 07'h. The register can be programmed to any 8-bit value excluding the already defined (control) values shown in Table 3-1.

When both the TRANS_EN bit (Clause 22 Address 10'h in Table 3-15 or Clause 45 Address C001'h in Table 3-33) and the AKR_EN bit (Clause 22 Address 1D'h in Table 3-28 or Clause 45 Address C001'h in Table 3-33) are set to 1, or when the XAUI_EN bit is set, the IDLE character data pattern will be sequenced into /A/, /K/, and /R/ codes (IEEE 802.3ae-2002 specified). Alternatively, if neither of the AKR_EN or XAUI_EN bits are set, the XGMII IDLE and the /K/ code will both be transmitted as the XAUI /K/ code, and the /A/ and /R/ control codes will be transmitted as XAUI /A/ and /R/ codes respectively. The 8b/10b encoding patterns are described in Table 3-1. For valid operation, the XGMII and XAUI Lane 0 signals should be connected to the BBT3420 Channel A pins.

When the XAUI_EN bit is set to 1, if a local/remote fault is received on the XAUI inputs, it will be passed as ||LF|| or ||RF|| Sequence Ordered_sets respectively, i.e., /K28.4/D0.0/D0.0/D1.0(D2.0)/. Local fault is declared when any of the following conditions are detected:

1. No signal is detected in any one of four channels.
2. No valid comma is detected in any one or more of the four channels.
3. When all the channels are not deskewed.

When the XAUI_EN bit is set to 1, if a local/remote fault K28.4/D0.0/D0.0/D1.0(D2.0)/ is written to the XGMII transmit interface for XAUI transmission, the ||LF|| or ||RF|| Sequence Ordered_set is transmitted according to the IEEE 802.3ae-2002 randomizing algorithm. Any other Sequence Ordered_set will also be transmitted in the same way.

TABLE 3-1. VALID 8B/10B ENCODER PATTERNS

| TRANSMITTING SERDES | | | | | | NOTES and DESCRIPTION |
|---------------------|---|-----------------------|---------------------|--------------------------|-------------|--------------------------------|
| K-BIT | TD DATA | TRANS_EN BIT (Note 1) | AKR_EN BIT (Note 1) | SERIAL CHARACTER | SERIAL CODE | |
| 0 | 0-FF'h | X | X | See 802.3-2002 Table36-1 | | Valid Data Value |
| 1 | = XGMII IDLE reg. (Note 2) (default 07'h) | 0 | X | Invalid code | | |
| | | 1 | 0 | /K/ | K28.5 | Comma (Sync) |
| 1 | BC | | X | 0 | /K/ | K28.5 |
| | | 1 | | /A/ /K/ /R/ | | IEEE802.3ae 48.2.4.2 algorithm |
| 1 | 7C | X | 0 | /A/ | K28.3 | Align |
| | | | 1 | /A/ /K/ /R/ | | IEEE802.3ae 48.2.4.2 algorithm |
| 1 | 1C | X | 0 | /R/ | K28.0 | Alternate Idle (Skip) |
| | | | 1 | /A/ /K/ /R/ | | IEEE802.3ae 48.2.4.2 algorithm |
| 1 | FB | X | X | /S/ | K27.7 | Start |
| 1 | FD | X | X | /T/ | K29.7 | Terminate |

TABLE 3-1. VALID 8B/10B ENCODER PATTERNS (Continued)

| TRANSMITTING SERDES | | | | | | NOTES and DESCRIPTION |
|---------------------|--------------|-----------------------|---------------------|------------------|-------------|-----------------------------|
| K-BIT | TD DATA | TRANS_EN BIT (Note 1) | AKR_EN BIT (Note 1) | SERIAL CHARACTER | SERIAL CODE | |
| 1 | 3C | X | X | | K28.1 | Extra comma |
| 1 | 5C | X | X | /F/ | K28.2 | Signal Ordered_Set marker |
| 1 | 9C | X | X | /Q/ | K28.4 | Sequence Ordered_Set marker |
| 1 | DC | X | X | | K28.6 | |
| 1 | FC | X | X | | K28.7 | Repeat gives False Comma |
| 1 | F7 | X | X | | K23.7 | |
| 1 | FE | X | X | /E/ | K30.7 | Error Code |
| 1 | (all others) | X | X | Invalid code | | Error Code |

NOTES:

1. If the XAUI_EN bit is set, the BBT3420 acts as though both the TRANS_EN and AKR_EN bits are set.
2. The XGMII IDLE character is set by the XGMII IDLE register, address 1B'h/C003'h (see Table 3-26), default value 07'h, combined with the K bit (XGMII value 107'h).

3.2 Transmit Byte Clock

3.2.1 FULL- AND HALF-RATE MODE

Since the BBT3420 normally employs Double Data Rate (DDR) timing, the local reference clock requirement is lowered to 124.4-159.375MHz. The Transmit Byte Clock (TBC) must be frequency-synchronous with the local reference clock. For any channel set to Half-Rate Clock Mode by the MDIO/MDC register 1F'h (for Clause 22) and/or C008'h (for Clause 45), see Table 3-30, the TBC must be provided at half the ref clock frequency, unless the TX_SDR bit is set in the MDIO register C001'h (Clause 45, Table 3-33) and/or 1D'h (Clause 22, Table 3-28).

3.2.2 SOURCE-CENTERED AND -SIMULTANEOUS MODE

For ease of ASIC timing, the BBT3420 provides the option for the TBC to be source-simultaneous or source-centered. In source-simultaneous mode, the ASIC is not required to adjust the TBC signal to the center of the data window. The internal latch clock of the BBT3420 is set to +5 serial bit times after the rising edge of the clock (TBC or RefClock) when the chip is reset. In source-centered mode, the BBT3420 expects stable data, with proper setup/hold time with respect to the TBC from the ASIC. The specific clocking mode is selectable by the MDIO/MDC register bit SC_TBC at address 11'h in Clause 22 format, Table 3-16, and/or C001'h in Clause 45 format, Table 3-33.

3.2.3 TRUNKING MODE

The TBC source for each channel is determined by the trunking mode setting of the PSYNC pin. When trunking is turned on (PSYNC high), all four channels are latched by the Channel A TBC on pin TCA. In non-trunking mode, each channel is latched with its corresponding TBC pin TC[A-D] independently. Note that PSYNC will also force trunking of the Receive Byte Clocks (see below). Alternatively, the TC[A-D]

inputs may be driven from a common source, such as the local reference clock.

3.3 Transmit FIFO

A 4-byte-deep input FIFO is used to accommodate any TBC or data drift. The initial pointer value is 2 bytes, which can accommodate ± 2 byte skew between channels, as well as drift between the TBC and the reference clock. When the FIFO depth is at one, the transmit data is ready for output on the next TXC.

3.4 Serializer

The serializer accepts 10-bit transmission characters and converts them from a parallel format to a serial bit stream at 2.488-3.1875Gbps. The system designer is expected to treat such signals on the PCB as transmission lines and to use a controlled impedance and suitable termination.

3.5 Pre-emphasis

In order to compensate for the loss of the high-frequency signal components through PCB or cable, four levels of programmable pre-emphasis have been added to all serial transmit channels. This maximizes the data eye opening at the receiver inputs and enhances the bit error rate performance of the system. The MDIO Register at Address 1C'h (for Clause 22) and/or C005'h (for Clause 45) (see Table 3-27) controls the level of pre-emphasis. Note that the formula used to determine the pre-emphasis value is NOT the same as that used in the IEEE 802.3ak-2004 specification for this parameter.

TABLE 3-2. PRE-EMPHASIS CONTROL

| CLAUSE 22 ADDRESS 1C'h OR CLAUSE 45 ADDRESS C005'h BIT 15 | CLAUSE 22 ADDRESS 1C'h OR CLAUSE 45 ADDRESS C005'h BIT 14 | PRE-EMPHASIS VALUE = $(V_{PP_{OUT}}/V_{PP})-1$ |
|---|---|--|
| 0 | 0 | No Pre-Emphasis |
| 0 | 1 | 0.18 |
| 1 | 0 | 0.38 |
| 1 | 1 | 0.75 |

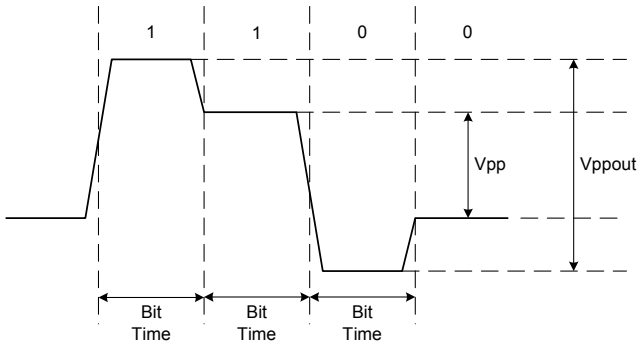

FIGURE 3-1. PRE-EMPHASIS OUTPUT ILLUSTRATION

3.6 Output Select – Serial Loopback

In normal mode, the serialized transmission TD[A..D][9..0] data will be placed on TX[A..D]P/N. When serial loopback is activated, Tx[AÖD] is internally looped back to Rx[AÖD] respectively.

3.7 Receiver

The receiver detects and recovers the serial clock and data from the received data stream. After acquiring bit synchronization, the BBT3420 normally searches the serial bit stream for the occurrence of a comma character to obtain byte synchronization (byte alignment). The receiver then performs channel alignment and clock compensation, as desired. These are each discussed in the sections below.

3.7.1 Input Equalization and Transmission Line Termination

An equalizer has been added to each receiver input buffer, which boosts high-frequency edge response. The boost factor can be selected from 0 to F'h through MDIO. The MDIO register at address 1C'h (Clause 22), and/or C005'h (Clause 45), see Table 3-27, controls the boost value of the equalizer functions. A nominal 100Ω on-chip transmission-line termination resistor is integrated with the input equalizer, eliminating the requirement of an external termination resistor. This greatly improves the effectiveness of the termination, providing the best possible signal integrity.

3.7.2 Loss of Signal (LOS)

Loss of signal is an indication of gross signal error conditions. It is not an indication of signal coding health. It may be caused by poor connections, insufficient voltage swings, or out-of-range signal frequency. If any of these conditions occurs, the SIG_DET pin will be de-asserted. In addition, the MDIO MF_CTRL register bits (Address 10'h for Clause 22 format, Table 3-15, and/or C001'h for Clause 45 format, Table 3-33) can be set to have the MF[A-D] pins provide per-channel indication of Loss of Signal conditions, the threshold being set by the MDIO LOS_CONTROL register bits at Address 1D'h for Clause 22 format and/or C001'h for Clause 45 format, Table 3-28 and/or Table 3-33 respectively. The LOS indication is also available directly in the MDIO status registers, Address 01'h in Clause 22 format, see Table 3-9, and/or Address C009'h in Clause 45 format, see Table 3-31. The combination of all four drives the SIG_DET pin (see Table 4-6), and contributes to the RX_FAULT bit in the IEEE Status Register 2 at address (00)08'h (Table 3-14) and the LOCAL_FLT bit in Register 0001'h, 1 in Table 3-10 (Clause 45 only).

As mentioned previously, LOS is designed as an indicator. The listed LOS threshold is for reference only, it is not designed to measure signal amplitude. Under nominal operation conditions, the actual LOS threshold is at a signal swing (single-ended peak-peak) lower or around the datasheet specified threshold. For a low LOS threshold setting, LOS may never be asserted due to noise.

3.7.3 Clock and Data Recovery

The line rate receive clock is extracted from the transition-rich 10-bit coded serial data stream independently on each channel. The data rate of the received serial bit stream for XAUI should be 3.125Gbps ±100ppm to guarantee proper reception (and similarly for other data rates). The receive clock locks to the input within 2µs after a valid input data stream is applied. The received data is de-serialized and byte-aligned.

The CDR unit will inherently acquire synchronization, provided the signal level is adequate, and the frequency is within the specified range of the local reference clock. If synchronization is lost due to an invalid signal (e.g. disconnect, out of range voltage swing, out of range frequency, etc.), then the high-speed receive clock will free run frequency-locked to the transmit clock.

3.7.4 Byte Alignment (code-group alignment)

Unless the CDET bits of the MDIO Register at address 10'h (Table 3-15, Clause 22) and/or C000'h (Table 3-32, Clause 45) are turned off, the Byte Alignment Unit is activated. The Byte Alignment Unit searches the coded incoming serial stream for a sequence defined in IEEE 802.3-2002 subclause 36.2.4.8 as a "comma". A comma is the sequence "0011111" or "1100000" and is uniquely located in a valid 8b/10b coded data stream, appearing as the start of some control symbols, including the /K/ IDLE. Any proprietary encoding scheme used should either incorporate these codes, or arrange byte alignment differently.

Comma disparity action can be controlled via the CDET bits. Upon detection of a comma, the Byte Alignment Unit shifts the incoming data to align the received data properly in the 10-bit character field. Two possible algorithms may be used for byte alignment. The default is to byte-align on any comma pattern. Although quick to align, and normally very reliable, this method is susceptible to realignment on certain single-bit errors or on successive K28.7 characters. The alternative algorithm is that specified in the IEEE802.3ae-2002 clause 48 specification, and is much less susceptible to error. Algorithm selection is controlled via MDIO register bit PCS_SYNC_EN at address 1D'h (Clause 22, Table 3-28) and/or C000'h (Clause 45, Table 3-32), unless overridden by the XAUI_EN bit in the same registers. The recovered receive clocks may be stretched (never slivered) during byte alignment, but up to a full code group may be deleted or modified while aligning the "comma" code group correctly to the edges of the RefClock.

3.7.5 Data Decoding

The serial bit stream must be ordered "abcdeifghj" with "a" being the first bit received and "j" the last. With the 10b/8b XGMII decoder enabled, the decoded data is ordered "ABCDEFGHJK" with "A" being the LSB. The decoding of valid 10b patterns is shown in Table 3-3 below. If the TRANS_EN bit or XAUI_EN bit (the MDIO Registers at Clause 22 addresses 10'h and 1D'h, see Table 3-15 and Table 3-28), and/or Clause 45 address C001'h, see Table 3-33) are set, all incoming XAUI IDLE patterns will be converted to the XGMII IDLE pattern set by the control register at address 1B'h (Clause 22 format) and/or C003'h (Clause 45 format), with a default value 107'h, the standard XGMII IDLE code (see Table 3-26). If neither bit is set, the incoming IDLE codes will all be decoded to the appropriate XGMII control code values. The first full column of IDLEs after any column containing a non-IDLE will be stored in the elasticity FIFO, and all subsequent full IDLE columns will repeat this pattern, until another column containing a non-IDLE is received.

If the BBT3420 XAUI_EN bit is set or the PCS_SYNC_EN and DSKW_SM_EN bits are set, and the device has detected a 'Local Fault' (see Table 3-10, Table 3-14, Table 3-28 and/or Table 3-32 & Table 3-33), the XGMII output will consist of the Sequence control character in channel A (XAUI lane 0) and data characters of 0x00 in channels B & C (lanes 1 and 2) plus a data character of 0x01 in channel D (lane 3), the IEEE-defined ||LF|| Sequence Ordered_Set.

TABLE 3-3. VALID 10b/8b DECODER PATTERNS

| RECEIVING SERDES | | | | | NOTES DESCRIPTION |
|---------------------------|--------------------------|-------|-------|----------------------------|---|
| SERIAL CODE, CHARACTER | TRANS_EN BIT (Note 2) | E-BIT | K-BIT | RD DATA | |
| Valid Data | X | 0 | 0 | 0-FF'h | Same Data Value as Transmitted |
| /K/ (Sync) K28.5 | 1 | 0 | 1 | = XGMII IDLE (Note 3) | Default 107'h |
| | 0 | 0 | 1 | BC | Comma (Note 1) |
| /A/ (Align) K28.3 | 1 | 0 | 1 | = XGMII IDLE (Note 3) | Default 107'h |
| | 0 | 0 | 1 | 7C | Align (Note 1) |
| /R/ (Skip) K28.0 | 1 | 0 | 1 | = XGMII IDLE (Note 3) | Default 107'h |
| | 0 | 0 | 1 | 1C | Alternate Idle (Note 1) |
| /S/ K27.7 | X | 0 | 1 | FB | Start |
| /T/ K29.7 | X | 0 | 1 | FD | Terminate |
| K28.1 | X | 0 | 1 | 3C | Extra comma |
| /F/ K28.2 | X | 0 | 1 | 5C | Signal Ordered_Set marker |
| /Q/ K28.4 | X | 0 | 1 | 9C | Sequence Ordered_Set marker |
| K28.6 | X | 0 | 1 | DC | |
| K28.7 | X | 0 | 1 | FC | Two will have caused byte realignment |
| K23.7 | X | 0 | 1 | F7 | |
| /E/ K30.7 | X | 1 | 1 | FE | Error |
| Any other | X | 1 | | = XGMII ERROR reg.(Note 3) | Error Code, Default 1FF'h, see Table 3-19 |

NOTES:

1. First incoming IDLE only, subsequent IDLEs in that block repeat first received code.
2. If the XAU1_EN bit is set, the BBT3420 acts as though the TRANS_EN bit is set.
3. The XGMII IDLE character is set by the XGMII IDLE register, address 1B'h/C003'h (see Table 3-26), default value 07'h, combined with the K bit. The XGMII ERROR code is similarly set by the XGMII ERROR register, address 16'h/C002'h (see Table 3-19)

3.8 Receive FIFO

The Receive FIFO performs two functions:

1. Channel Alignment
2. Clock Compensation

3.8.1 CHANNEL ALIGNMENT (DESKEW)

Trunking, also known as deskewing, means the alignment of packet data across multiple channels. 8 byte of RXFIFO is dedicated for channel alignment.

During high-speed transmission, different active and passive elements in the links may impart varying delays in the four channels. In trunking mode, multiple channels share the same clock (local reference or recovered clock A), which is used for outputting data on the parallel bus.

As defined by IEEE 802.3ae-2002, packets must start on channel A (equivalent to Lane 0 in the IEEE 802.3ae-2002 specification). Deskewing is accomplished by monitoring the contents of the FIFOs to detect the boundary between IDLE sequences and any non-IDLE data (including data and the /S/

code), which defines the beginning of the packet, or the presence of the IEEE 802.3ae-defined /A/ character, for channel alignment (controlled by MDIO Register 19'h in Clause 22 format and/or C000'h in Clause 45 format, see Table 3-24 and/or Table 3-32). When this alignment data is detected in all four channels, the trunking channel-alignment operation is performed, and will be held until another such transition or /A/ character is detected again on any channel. To maintain channel alignment, such transitions or /A/ characters should occur on all four channels simultaneously (i.e. within the span of the FIFO). During channel realignment, up to four code groups may be deleted, repeated or garbled on any channel.

The deskew state machine is enabled by setting the DSKW_SM_EN bit (Clause 22 Address 1D'h see Table 3-28; Clause 45 Address C000'h see Table 3-32) to 1. The deskew algorithm is implemented according to IEEE spec. 802.3ae. Note that when DSKW_SM_EN is set to 1, the CAL_EN bit (Clause 22 Address 19'h see Table 3-24; Clause 45 Address C000'h see Table 3-32) is ignored. When the DSKW_SM_EN bit is set to 0, channel deskew can still be enabled by setting

CAL_EN, but the deskew action will be carried out without hysteresis.

The user has the option to disable trunking, or enable trunking across 4 channels, under control of the PSYNC pin (Table 4-6) and the RCLKMODE bits in the MDIO Registers at address 18'h in Clause 22 format and/or C000'h in Clause 45 format (see Table 3-21 and/or Table 3-32). In trunking mode, the channels may have phase differences, but they are expected to be frequency synchronous. In non-trunking mode, each received serial stream need only be within ± 100 ppm of 3.125Gbps (or 1.56125) Gbps. Note that trunking mode is only possible if 8b/10b Coding is activated, and all channels have the same half-rate setting (Table 3-30).

3.8.2 CLOCK COMPENSATION

In addition to deskew, the Receive FIFO also compensates for clock differences. Since the received serial stream can, under worst-case conditions, be off by up to ± 200 ppm from the local clock domain (both can be up to ± 100 ppm from nominal), the received data must be adjusted to the local frequency. The received data can be aligned in one of three ways, under control of the PSYNC pin (Table 4-6) and the RCLKMODE bits in MDIO Register 18'h in Clause 22 format and/or C000'h in Clause 45 format (see Table 3-21 and/or Table 3-32):

1. Local Reference Clock (trunking mode)
2. Recovered Clock for each channel (non-trunking mode)
3. Recovered Clock for Channel A (trunking mode)

Another 8 bytes of RXFIFO are dedicated for clock compensation. The FIFOs achieve clock tolerance by identifying any of the IDLE patterns in the XAUI input (/K/, /A/ or /R/ as defined by the IEEE 802.3ae-2002 standard) in the received data and then adding or dropping IDLEs as needed. The Receive FIFO does not store the actual IDLE sequences received but generates the number of IDLEs needed to compensate for clock tolerance differences. See also Table 3-3 on page 8.

3.9 Error Recovery

Errors in the high-speed links can be separated into two types, Loss of Signal and Coding Error violations. These are handled differently by the Error Recovery system in the BBT3420.

3.10 Disparity Error & Coding Violation

3.10.1 XGMII 8 BIT MODE

If 8b/10b encoding/decoding is turned on, the BBT3420 expects to receive a properly encoded serial bit stream. If the received data contains an error, the transceiver will report it as described below:

The received bits 0-7 represent the 8b/10b decoded value, bit 8 represents the K value and bit 9 indicates a disparity error or code error. In the event of a disparity error, the decoded value is passed to the parallel output [8..0], and bit 9 is asserted to indicate the error. If it is a coding error, the decoded value presented is a programmable error byte (default=K30.7).

Therefore the value for bit 0-8 is 1,1111,1110'b. Bit 9 is asserted to indicate the error.

This transceiver does not support the even/odd character mode specific to 1000Base-X operations. Byte alignment with comma is achieved with a 10-bit period. As a result, a comma received at any odd or even byte location, but at the proper byte boundary, will not cause any byte realignment.

3.10.2 10-BIT MODE

If the 8b/10b Codec is inactive, disparity error and coding violation errors do not apply. System designers must ensure that the data stream is DC-balanced and contains sufficient transition density for proper operation, including synchronization. The required density depends on the frequency difference between the received data and the local reference clock, and the incoming signal jitter tolerance requirement. For a frequency difference of ± 100 ppm, and a transition-free data pattern of 500 successive 1's or 0's, the total build-up of CDR timing error is 0.1 UI. If this pattern is followed by a pattern of normal density, the reduction of jitter tolerance will usually be acceptable, though if such long no-transition patterns are common, the jitter buildup could be cumulative. In a fully synchronous system, where there are no consistent frequency differences, these effects are of course reduced.

3.10.3 OUTPUT SELECT – PARALLEL LOOPBACK

In normal mode, the serial input data RX[A..D]P/N data will be placed on the parallel receive outputs RD[A..D][9..0]. When parallel loopback is activated, the internal parallel output is routed to the parallel input (including clock) for every channel. The RD[A..D][9..0] pins may be disabled if desired, whether in parallel output mode or not, by using the IPON bit of the MDIO Register at address 011'h (Clause 22 see Table 3-16) and/or address C001'h (Clause 45, see Table 3-33).

TABLE 3-4. MDIO MANAGEMENT FRAME FORMATS

| Clause 22 Format (from Table 22-10 in IEEE Std 802.3-2002) | | | | | | | | |
|--|-------|----|----|-------|-------|----|----------------------|------|
| Operrn | PRE | ST | OP | PHYAD | REGAD | TA | DATA | IDLE |
| Read | 1...1 | 01 | 10 | PPPPP | RRRRR | Z0 | DDDDDDDDDDDDDDDDDD | Z |
| Write | 1...1 | 01 | 01 | PPPPP | RRRRR | 10 | DDDDDDDDDDDDDDDDDD | Z |
| Clause 45 Format (from Table 45-64 in IEEE 802.3.ae-2002) | | | | | | | | |
| Operrn | PRE | ST | OP | PRTAD | DEVAD | TA | ADDRESS/DATA | IDLE |
| Addr | 1...1 | 00 | 00 | PPPPP | DDDDD | 10 | AAAAAAAAAAAAAAAAAAAA | Z |
| Write | 1...1 | 00 | 01 | PPPPP | DDDDD | 10 | DDDDDDDDDDDDDDDDDD | Z |
| Read | 1...1 | 00 | 11 | PPPPP | DDDDD | Z0 | DDDDDDDDDDDDDDDDDD | Z |
| Read Inc | 1...1 | 00 | 10 | PPPPP | DDDDD | Z0 | DDDDDDDDDDDDDDDDDD | Z |

3.11 Serial Management Interface

The BBT3420 implements both the Management Interface defined in IEEE 802.3 Clause 22, and that defined in Clause 45. This two-pin interface allows serial read/write of the internal control registers and consists of the MDC clock and MDIO data terminals. The PADR[4..0] pins are used to select the address to which a given BBT3420 device responds. The remainder of the MDIO frame and access details depend on the respective formats. The BBT3420 automatically detects which format is being used on a frame-by-frame basis, based on the second START bit. The two formats are shown in Table 3-4, together with the references to the respective IEEE 802.3 specifications. The fields are as follows:

- PRE, the Preamble field: at least 32 consecutive ‘1’ bits. The BBT3420 will accept any number ≥32.
- ST, the Start of Frame; for Clause 22, <01>; for Clause 45, <00>.
- OP, the Operation code; for Clause 22, Read and Write operations are defined, all other values are invalid; for Clause 45, additional operations to send the 16-bit (indirect) register address, and to read data and (then) increment the stored address are added.
- PHYAD/PRTAD; the PHYSical (Clause 22) or PoRT (Clause 45) hardware ADDRESS; this 5-bit address must match the PADR pins on the BBT3420.
- REGAD, REGister ADDRESS (Clause 22); this 5-bit address specifies the register address. Replaced by the 16-bit address value in Clause 45 format.
- DEVAD, DEvice ADDRESS (Clause 45); this 5-bit address specifies which MMD at any given port is being addressed. See Table 3-5 and section 3.13 for the possible values the BBT3420 will respond to.
- TA, the TurnAround; allows time to avoid contention for a read operation on the MDIO line.
- DATA; the 16 bit data values to be written to or being read from the BBT3420.
- ADDRESS (Clause 45); this 16-bit address specifies the register address for subsequent Clause 45 read or write

operations. A Read Increment operation will post-increment the value.

- IDLE; this condition flags the end of the frame. Since the IEEE specification calls for a pullup on the MDIO line, this effectively provides the MMD with a ‘1’ character, which can be the beginning of the next Preamble.

TABLE 3-5. DEVAD DEVICE ADDRESS SETUP TABLE

| MFD | MFC | DEVAD VALUE | DEFAULT | IEEE DEFINITION |
|-----|-----|----------------------|---------|----------------------|
| 1 | 1 | DEVAD = 5 (000101'b) | 11'b | DTE XS (XGXS Device) |
| 1 | 0 | DEVAD = 4 (00100'b) | | PHY XS (XGXS Device) |
| 0 | 1 | DEVAD = 31 (11111'b) | | Vendor Specific |
| 0 | 0 | DEVAD = 30 (11110'b) | | Vendor Specific |

3.12 Clause 22 PHY Addressing

The PADR[4..0] hardware address pins control the PHYAD value, allowing use of up to 31 BBT3420 (or other compatible) devices on any MDC/MDIO line pair. Each device may contain up to 32 registers, some of which are defined by the IEEE standard, the others being Vendor-defined. The Clause 22-accessible registers are listed in Table 3-6.

3.13 Clause 45 PHY Addressing

The PADR[4..0] hardware address pins control the PRTAD (Port Address) value, each port normally consisting of a series of MDIO Managed Devices (MMDs). Each of the up to 31 Ports may include up to 31 different devices, of which the current specification defines 6 types, and allows vendor specification of two others. The native-mode BBT3420 corresponds to two of the defined types; it can be either a PHY XS (DEVAD = 4) or a DTE XS (DEVAD = 5), but may also be used as part of another defined type, or as a RETIMER function. The device may be set to respond to any one of four DEVAD values, (4, 5, 30 or 31) by controlling the level on the MFC and MFD pins at the end of reset. These pins are normally outputs, but become

inputs when RSTN is active, and so may be pulled to the desired value by moderate value resistors (~5kΩ), which will not affect the normal operation of the pins when outputs. The value on these pins will be latched at the rising edge of RSTN. The coding is shown in Table 3-5. A weak pullup is built into these pins, so that if unwired, they will default to DEVAD = 5. See Table 6-13 and Figure 6-9 for the timing of these signals. The Clause 45-accessible registers are listed in Table 3-7. These register addresses are independent of the DEVAD value, including the 'Vendor Defined' DEVAD values 30 & 31; thus registers 30.8 & 31.8 include the RX_FAULT and TX_FAULT bits.

Each individual device may have up to 2¹⁶ (65,536) registers. The BBT3420 implements 11 of the IEEE-defined registers for PHY XS and DTE XS devices (they may be accessed identically through any of the implemented DEVAD address

values), and 11 of the 32k (2¹⁵) allowed Vendor Specific registers. The latter have been placed in the block beginning at C000'h so as to avoid the areas currently defined as for use by the XENPAK module and similar MSA devices, to facilitate use of the BBT3420 in systems using such modules and/or devices.

In order to align the registers and bits as closely as possible to the new IEEE Clause 45 standard, while maintaining compatibility with previous versions of the part before the Clause 45 interface was defined, which used only the Clause 22 interface, the control and status bits are differently distributed among the registers in the two formats. The Clause 22 registers are listed in Table 3-6, and the Clause 45 registers in Table 3-7.

TABLE 3-6. MDIO REGISTERS IN CLAUSE 22 FORMAT

| MII REGISTERS | | | | | |
|---------------|--------------------------|--|-----------------|-------|--------------|
| ADDRESS | NAME | DESCRIPTION | DEFAULT | R/W | DETAILS |
| 00'h | Control | Reset, Enable serial loop back mode. | 2040'h | R/W | Table 3-8 |
| 01'h | Status | Device Present & LOS | 800F'h (Note 2) | RO | Table 3-9 |
| 02:3'h | ID Code | Manufacturer and Device OUI & IDs | 01839C5V'h | RO | See (Note 1) |
| 04'h | Speed Ability | 10Gbps Ability | 0001'h | RO | Table 3-11 |
| 05'h | IEEE Devices | Devices in Package, Clause 22 capable | 0021'h (Note 3) | RO | Table 3-12 |
| 06'h | Vendor Devices | Vendor Specific Devices in Package | 0000'h (Note 3) | RO | Table 3-13 |
| 08'h | Fault Status | Transmit & Receive Fault | 8000'h (Note 2) | RO/LH | Table 3-14 |
| 10'h | Misc. Control 1 | Channel, Comma, TX Idle, MF controls | 00C0'h | R/W | Table 3-15 |
| 11'h | Misc. Control 2 | Code, Comma, Codec, TCx controls | 0140'h | R/W | Table 3-16 |
| 12'h | Special Control Register | DC Offset & RC[A:D] phase shift control | 0000'h | R/W | Table 3-17 |
| 13'h | Resvd2 | Spare Status | 0000'h | RO | Table 3-18 |
| 16'h | ERROR | Sets XGMII ERROR Code | 0FF'h | R/W | Table 3-19 |
| 17'h | Loop Back | Controls Serial & Parallel Loopback | 0000'h | R/W | Table 3-20 |
| 18'h | Receive Clock | Receive Clock Mode | 0001'h | R/W | Table 3-21 |
| 19'h | Symbol | IDLE, Alignment and Elasticity Control | 000F'h | R/W | Table 3-24 |
| 1A'h | Errors | Error Flags | 0000'h (Note 2) | RO | Table 3-25 |
| 1B'h | XGMII IDLE | XGMII-side IDLE Code | 0007'h | R/W | Table 3-26 |
| 1C'h | Boost/Pre-emp | Boost and Pre-emphasis Control | 0000'h | R/W | Table 3-27 |
| 1D'h | Misc. Control 3 | V _{DDQ} , LOS, RC timing, /A/K/R/ | 0000'h | R/W | Table 3-28 |
| 1E'h | Internal Test | | AAAA'h | R/W | Table 3-29 |
| 1F'h | Half Rate | Half-rate clock mode enable | 0000'h | R/W | Table 3-30 |

NOTES:

1. 'V' is a version number. See under "3.15 JTAG" on page 22 for a note about the version number.
2. Read value depends on status signal values. Value shown indicates 'normal' operation.
3. Read value depends on DEVAD setting, see Table 3-5 and Figure 6-9 for details.

TABLE 3-7. MDIO REGISTERS IN CLAUSE 45 FORMAT

| MII REGISTERS | | | | | |
|---------------|--------------------------|--|-----------------|--------|--------------|
| ADDRESS | NAME | DESCRIPTION | DEFAULT | R/W | DETAILS |
| 0000'h | XGXS Control 1 | Reset, Enable serial loop back mode. | 2040'h | R/W | Table 3-8 |
| 0001'h | XGXS Status 1 | Fault, Link Status | 0004'h (Note 2) | RO LL | Table 3-10 |
| 0002:3'h | ID Code | Manufacturer and Device OUI & IDs | 01839C5V'h | RO | See (Note 1) |
| 0004'h | Speed Ability | 10Gbps Ability | 0001'h | RO | Table 3-11 |
| 0005'h | IEEE Devices | Devices in Package, Clause 22 capable | 0021'h(3) | RO | Table 3-12 |
| 0006'h | Vendor Devices | Vendor Specific Devices in Package | 0000'h(3) | RO | Table 3-13 |
| 0008'h | XGXS Status 2 | Device Present, Local Fault | 8000'h (Note 2) | RO | Table 3-14 |
| 0018'h | 10G Lane Status | Receive Channels Aligned, Synched | 100F'h (Note 2) | RO | Table 3-23 |
| C000'h | Misc. Control 1 | V _{DDQ} , RC, Code, Comma, Stt Mach | 072F'h | R/W | Table 3-32 |
| C001'h | Misc. Control 2 | BIST, LOS, XAUI, TX, MF controls | 0010'h | R/W | Table 3-33 |
| C002'h | ERROR | Sets XGMII ERROR Code | 0FF'h | R/W | Table 3-19 |
| C003'h | XGMII IDLE | XGMII-side IDLE Code | 0007'h | R/W | Table 3-26 |
| C004'h | Loop Back | Controls Serial & Parallel Loopback | 0000'h | R/W | Table 3-20 |
| C005'h | Boost/Pre-emp | Boost and Pre-emphasis Control | 0000'h | R/W | Table 3-27 |
| C006'h | Errors | Error Flags | 0000'h (Note 2) | RO | Table 3-25 |
| C007'h | Special Function | MUST be left at Default Value | AAAA'h | R/W | Table 3-29 |
| C008'h | Half Rate | Half-rate clock mode enable | 0000'h | R/W | Table 3-30 |
| C009'h | LOS Status | LOS Channel Status | 00F0'h (Note 2) | RO LH | Table 3-31 |
| C00A'h | Special Control Register | DC Offset & RC[A:D] phase shift control | 0000'h | R/W | Table 3-17 |
| C00B'h | Reserved | Spare Status | 0000'h | RO | Table 3-18 |
| C00F'h | Soft Reset | Reset (non-MDIO) | 0000'h | R/W SC | Table 3-34 |

NOTES:

4. 'V' is a version number. See JTAG on page 25 for a note about the version number.
5. Read value depends on status signal values. Value shown indicates 'normal' operation.
6. Read value depends on DEVAD setting, see Table 3-5 and Figure 6-9 for details.

3.14 MDIO Registers

In the following tables, the Clause 45 addresses are given after the Clause 22 address in the table header, where the registers coincide in structure, but the addresses differ. Separate tables

are given for registers and bits differently constructed. The underlying register bits are the same, and may be read or written indiscriminately in either format (except for a few bits that are not accessible via the Clause 22 format).

TABLE 3-8. IEEE XGXS CONTROL 1 REGISTER

| MII REGISTER 0, ADDRESSES = 00'h & 0000'h | | | | | |
|---|-----------|----------------|---------|--------|---|
| BIT | NAME | SETTING | DEFAULT | R/W | DESCRIPTION |
| 15 | Reset | 1 = reset | 0'b | R/W SC | Self-clearing reset. Writing 1 to this bit will reset the whole chip, including the MDIO registers. |
| | | 0 = reset done | | | |
| 14 | LOOP_EN | 1 = enable | 0'b | R/W | Enable serial loopback mode. |
| 13 | SPEEDSEL0 | 1 = 10Gbps | 1'b | RO | Writes ignored |
| 12 | Reserved | | | | |
| 11 | LOPOWER | 1 = Low Power | 0'b | R/W | No Low Power Mode, ignored |
| 10:7 | Reserved | | | | |
| 6 | SPEEDSEL1 | 1 = 10Gbps | 1'b | RO | Writes ignored |
| 5:2 | SPEEDSEL | 0 = 10Gbps | 0'h | RO | Writes ignored |
| 1:0 | Reserved | | | | |

TABLE 3-9. IEEE XGXS STATUS 1 REGISTER (CLAUSE 22)

| MII REGISTER 1, ADDRESS = 01'h | | | | | |
|--------------------------------|----------------|---|---------|-------|--|
| BIT | NAME | SETTING | DEFAULT | R/W | DESCRIPTION |
| 15:14 | Device present | 10 = Device present | 10'b | RO | Indicates that a device is present at this device address |
| 13 | LOS_D | 1 = Signal less than threshold 0 = Signal greater than threshold | 0'b | RO/LH | Loss Of Signal for RX Inputs of each of 4 channels; signal less than LOS_CONTROL value (see Table 3-28 and/or Table 3-33) (Note 1) |
| 12 | LOS_C | | 0'b | | |
| 11 | LOS_B | | 0'b | | |
| 10 | LOS_A | | 0'b | | |
| 9:4 | Reserved | | 00'h | RO | |
| 3:0 | Internal | | F'h | RO | Internal Function (ignore) |

NOTE:

1. Please refer to section "3.7.2 Loss of Signal (LOS)" on page 6 for a more detailed description.

TABLE 3-10. IEEE XGXS STATUS 1 REGISTER (CLAUSE 45)

| MII REGISTER 1, ADDRESS = 0001'h | | | | | |
|----------------------------------|-----------|-------------------|---------|-------|------------------------------|
| BIT | NAME | SETTING | DEFAULT | R/W | DESCRIPTION |
| 15:8 | Reserved | | 00'h | RO | |
| 7 | LOCAL_FLT | 1 = Local Fault | 0'b | RO | Derived from Register 0008'h |
| 6:3 | Reserved | | | | |
| 2 | RX_LINK | 1 = XGXS Link up | 1'b | RO LL | XAUI Receive Link Status |
| 1 | LoPwrAble | Low Power Ability | 0'b | RO | Does not support Low Power |
| 0 | Reserved | | | | |

TABLE 3-11. IEEE SPEED ABILITY REGISTER

| MII REGISTER 4, ADDRESSES = 04'h & 0004'h | | | | | |
|---|----------|-----------------|---------|-----|--------------|
| BIT | NAME | SETTING | DEFAULT | R/W | DESCRIPTION |
| 15:1 | Reserved | | 000'h | RO | |
| 0 | 10G_Able | 1 = 10Gbps Able | 1'b | RO | 10GE Capable |

TABLE 3-12. IEEE DEVICES IN PACKAGE REGISTER

| MII REGISTER 5, ADDRESSES = 05'h & 0005'h | | | | | |
|---|-------------|--------------------|------------|-----|---|
| BIT | NAME | SETTING | DEFAULT | R/W | DESCRIPTION |
| 15:7 | Reserved | | 000'h | RO | |
| 6 | TC | TC present | 0'b | RO | Device ignores DEVAD 6 (TC not present) |
| 5 | DTE XS | 1 = DTE XGXS | P (Note 1) | RO | Device responds to DEVAD 5 |
| 4 | PHY XS | 1 = PHY XGXS | P (Note 1) | RO | Device responds to DEVAD 4 |
| 3 | PCS | 1 = PCS | 0'b | RO | Device ignores DEVAD 3 |
| 2 | WIS | 1 = WIS | 0'b | RO | Device ignores DEVAD 2 |
| 1 | PMD/PMA | 1 = PMD/PMA | 0'b | RO | Device ignores DEVAD 1 |
| 0 | Cls 22 Regs | 1 = MDIO Clause 22 | 1'b | RO | Device responds to Clause 22 |

NOTE:

- Value depends on DEVAD setting; see Table 3-5. 1 = responds, 0 = does not respond.

TABLE 3-13. VENDOR SPECIFIC DEVICES IN PACKAGE REGISTER

| MII REGISTER 6, ADDRESSES = 06'h & 0006'h | | | | | |
|---|-------------|-------------------|------------|-----|--|
| BIT | NAME | SETTING | DEFAULT | R/W | DESCRIPTION |
| 15 | Vend Spec | 1 = V S D present | S (Note 1) | RO | Vendor Specific Device Present in Package |
| 14 | Reserved | | 0'b | RO | |
| 13 | Ext. Cls 22 | | 0'b | RO | No extended Clause 22 registers in Package |
| 12:0 | Reserved | | 000'h | RO | |

NOTE:

- Value depends on DEVAD setting; see Table 3-5. 1 = responds, 0 = does not respond.

TABLE 3-14. IEEE XGXS STATUS2 REGISTER

| MII REGISTER 8, ADDRESSES = 08'h & 0008'h | | | | | |
|---|----------------|---------------------|---------|-------------------|--|
| BIT | NAME | SETTING | DEFAULT | R/W | DESCRIPTION |
| 15:14 | Device present | 10 = Device present | 10'b | RO | Indicates a device is present at this device address |
| 13:12 | Reserved | | | | |
| 11 | TX_FAULT | 1 = Tx Local Fault | 0'b | RO LH (Note 1) | Transmit Fault Detector. Always 0 |
| 10 | RX_FAULT | 1 = Rx Local Fault | 0'b | RO LH (Note 1) | Derived from Reg. 0024'h, Byte Sync and Alignment bits (not accessible via Clause 22), and 01'h/C009'h Loss Of Signal bits |
| 9:0 | Reserved | | | | |

NOTE:

- These bits are latched high on any fault condition detected. They are reset low upon being read.

TABLE 3-15. MISCELLANEOUS CONTROL REGISTER 1 (CLAUSE 22)

| MII REGISTER 16, ADDRESS = 10'h | | | | | |
|---------------------------------|-----------|--|---------|-----|--|
| BIT | NAME | SETTING | DEFAULT | R/W | DESCRIPTION |
| 15:8 | Reserved | | | | |
| 7:6 | CDET[1:0] | Bit 7 controls positive comma detection, Bit 6 controls negative comma detection 0'b=disable 1'b=enable | 11'b | R/W | Comma Detect Select. These bits enable detection of positive, negative, or both positive and negative disparities of comma, or disable detection of either. |
| 5:4 | Reserved | | | | |
| 3 | TRANS_EN | 1=enable 0=disable | 0'b | R/W | Enables transceiver to translate an "IDLE" pattern in the XGMII data (matching the value of register 1B'h) to and from the XAUI IDLE /K/ comma character or /A/, /K/ & /R/ characters. Overridden by XAUI_EN; see Table 3-28 |
| 2:0 | MF_CTRL | 0 = BIST_ERR 1 = LOS 2 = Reserved 3 = RC[A:D] 4 = TXFIFO_ERR 5 = AFIFO_ERR 6 = EFIFO_ERR | 00'b | R/W | Control the functions of multi-function pins MF[A-D]. RC[A:D] is recovered clock for each channel [A:D]. |

TABLE 3-16. MISCELLANEOUS CONTROL REGISTER 2 (CLAUSE 22)

| MII REGISTER 17, ADDRESS = 11'h | | | | | |
|---------------------------------|-----------|---|---------|-----|--|
| BIT | NAME | SETTING | DEFAULT | R/W | DESCRIPTION |
| 15 | SHRT_BIST | 1 = Short BIST Loop pattern 0 = Long BIST Loop pattern | 0'b | R/W | Short is 13458 Byte pattern, Long is $2^{23}-1$ Byte Pattern (plus 9 /K/ "Comma" bytes) |
| 14:13 | Reserved | | | | |
| 12 | BIST_EN | 1 = enable BIST Pattern 0 = disable | 0'b | R/W | Built In Self Test (BIST) may also be enabled by the BIST_EN pin or via the JTAG system. |
| 11:9 | Reserved | | | | |
| 8 | IPON | 1=enable 0=disable | 1'b | R/W | Internal Parallel Output Enable |
| 7 | Reserved | | | | |
| 6 | CODECENA | 1=enable if CODE pin hi 0=disable | 1'b | R/W | Internal 8b/10b Codec enable/disable |
| 5 | SC_TBC | 1=source sync 0=source center | 0'b | R/W | Timing of incoming Transmit Byte Clock (TBC) to transmit data |
| 4:0 | Reserved | | | | |

TABLE 3-17. SPECIAL CONTROL REGISTER

| MII REGISTER 18 & 49162, ADDRESSES = 12'h & C00A'h | | | | | |
|--|------------|---|---------|-----|---|
| BIT | NAME | SETTING | DEFAULT | R/W | DESCRIPTION |
| 15 | EQ_DC_D | 1=DC offset correction disable. 0=DC offset correction enable. | 0'b | R/W | Channel D receive differential input DC offset correction disable/enable. |
| 14 | EQ_DC_C | 1=DC offset correction disable. 0=DC offset correction enable. | 0'b | R/W | Channel C receive differential input DC offset correction disable/enable. |
| 13 | EQ_DC_B | 1=DC offset correction disable. 0=DC offset correction enable. | 0'b | R/W | Channel B receive differential input DC offset correction disable/enable. |
| 12 | EQ_DC_A | 1=DC offset correction disable. 0=DC offset correction enable. | 0'b | R/W | Channel A receive differential input DC offset correction disable/enable. |
| 11:8 | Reserved | | | | |
| 7:4 | Reserved | | 0'b | | |
| 3 | RCD_Invert | 1=invert phase, 0=default phase | 0'b | R/W | Invert RCD clock phase (RCD shift by 180 degrees) |
| 2 | RCC_Invert | 1=invert phase, 0=default phase | 0'b | R/W | Invert RCC clock phase (RCC shift by 180 degrees) |
| 1 | RCB_Invert | 1=invert phase, 0=default phase | 0'b | R/W | Invert RCB clock phase (RCB shift by 180 degrees) |
| 0 | RCA_Invert | 1=invert phase, 0=default phase | 0'b | R/W | Invert RCA clock phase (RCA shift by 180 degrees) |

TABLE 3-18. SPARE STATUS REGISTER

| MII REGISTER 19 & 49163, ADDRESSES = 13'h & C00B'h | | | | | |
|--|----------|---------|---------|-----|-------------|
| BIT | NAME | SETTING | DEFAULT | R/W | DESCRIPTION |
| 15:0 | Reserved | | | | |

TABLE 3-19. XGMII ERROR CODE REGISTER

| MII REGISTER 22 & 49154, ADDRESSES = 16'h & C002'h | | | | | |
|--|----------|---------|---------|-----|--|
| BIT | NAME | SETTING | DEFAULT | R/W | DESCRIPTION |
| 15:9 | Reserved | | | | |
| 8:0 | ERROR | N/A | 1FF'h | R/W | Error Code. These bits allow the ERROR character to be programmed. Overridden by XAUI_EN, see Table 3-28 and/or Table 3-33 |

TABLE 3-20. LOOP BACK CONTROL REGISTER

| MII REGISTER 23 & 49156, ADDRESSES = 17'h & C004'h | | | | | |
|--|----------|-----------------------|---------|-----|--|
| BIT | NAME | SETTING | DEFAULT | R/W | DESCRIPTION |
| 15:12 | Reserved | | | | |
| 11 | SLP_D | 1=enable 0=disable | 0'h | R/W | Internal Serial Loop Back Enable. These bits enable the loopback function for serial data for each individual channel. When high, they route the internal output of the Serializer to the input of the clock recovery block. |
| 10 | SLP_C | | | | |
| 9 | SLP_B | | | | |
| 8 | SLP_A | | | | |
| 7:4 | Reserved | | | | |
| 3 | PLP_D | 1=enable 0=disable | 0'h | R/W | Internal Parallel Loop Back Enable. These bits enable the loopback function for parallel data for each individual channel. When high, it routes the internal output of the Deserializer to the parallel input of each channel. |
| 2 | PLP_C | | | | |
| 1 | PLP_B | | | | |
| 0 | PLP_A | | | | |

TABLE 3-21. RECEIVE CLOCK MODE REGISTER (CLAUSE 22)

| MII REGISTER 24, ADDRESS = 18'h (CLAUSE 22) | | | | | |
|---|----------|--|---------|-----|--|
| BIT | NAME | SETTING | DEFAULT | R/W | DESCRIPTION |
| 15:2 | Reserved | | | | |
| 1:0 | RCLKMODE | Depends on RETIMER and PSYNC pins (Table 4-6). See settings in Table 3-22. | 01'b | R/W | Received Clock Mode. These two bits, together with the PSYNC and RETIMER pins, select which clock the received data is aligned to. |

TABLE 3-22. RCLKMODE BIT SETTINGS = 18'h.1:0 (CLAUSE 22) or C000'h.6:5 (CLAUSE 45)

| PIN NAME, LOGIC LEVEL | | REGISTER BIT SETTING | CHANNEL ALIGNMENT | RCLKMODE BITS, and PIN VALUES, to RECEIVE DATA CLOCK ALIGNMENT |
|-----------------------|-------|----------------------|-------------------|--|
| RETIMER | PSYNC | | | |
| 0 | 0 | XX | No | Local Reference Clock |
| 0 | 1 | XX | Yes | Local Reference Clock |
| X | 0 | 11'b | No | Local Reference Clock |
| X | 1 | 11'b | Yes | Local Reference Clock |
| 1 | 0 | 10'b | No | Recovered Clock for each individual channel |
| 1 | 1 | 10'b | Yes | Recovered Clock for Channel A |
| 1 | X | 0X'b | Yes | Recovered Clock for Channel A |

TABLE 3-23. PCS ALIGNMENT AND SYNC STATUS REGISTER (CLAUSE 45)

| MII REGISTER 24, ADDRESS = 18'h (CLAUSE 45) | | | | | |
|---|-------------|--|--------------|-----|---|
| BIT | NAME | SETTING | DEFAULT | R/W | DESCRIPTION |
| 15:13 | Reserved | | | | |
| 12 | Chan_ALIGN | 1 = aligned | 0'b (Note 1) | RO | Four channels are aligned |
| 11 | Test_P_Able | 0 | 0'b | RO | No IEEE802.3 test patterns (but see BIST discussion) |
| 10:4 | Reserved | | | | |
| 3 | SYNC_D | 1 = channel synchronized 0 = channel not synchronized | 0'b (Note 1) | RO | Reflects the PCS_SYNC byte alignment state machine condition; not valid if not enabled (see Table 3-28 and/or Table 3-32) |
| 2 | SYNC_C | | 0'b (Note 1) | RO | |
| 1 | SYNC_B | | 0'b (Note 1) | RO | |
| 0 | SYNC_A | | 0'b (Note 1) | RO | |

NOTE:

1. These bits contribute to the Receive Local Fault bit RX_FAULT in the IEEE XGXS Status2 Register (see Table 3-14). Also, these bits will reflect the input signal status if DSKW_SM_EN is enabled.

TABLE 3-24. SYMBOL AND ELASTICITY CONTROL (CLAUSE 22)

| MII REGISTER 25, ADDRESS = 19'h | | | | | |
|---------------------------------|-------------|-----------------------|---------|-----|---|
| BIT | NAME | SETTING | DEFAULT | R/W | DESCRIPTION |
| 15:4 | Reserved | | | | |
| 3 | IDLE_D_EN | 1=enabled, 0=disabled | 1'b | R/W | Enables IDLE vs. nonIDLE detection for Channel Alignment and Elasticity operations. |
| 2 | ELST_EN | 1=enabled, 0=disabled | 1'b | R/W | Enable the elastic function of the receiver buffer |
| 1 | A_ALIGN_DIS | 1=enabled, 0=disabled | 1'b | R/W | Receiver aligns data on incoming "/A/" characters (K28.3). If disabled (default), receiver aligns data on IDLE to nonIDLE transitions (if bit 3 set). Overridden by XAUI_EN, see Table 3-28 |
| 0 | CAL_EN | 1=enabled, 0=disabled | 1'b | R/W | Enable de-skew calculator of receiver buffer. (see Channel Alignment discussion) |

TABLE 3-25. ERROR FLAGS

| MII REGISTER 26 & 49158, ADDRESSES = 1A'h & C006'h | | | | | |
|--|------------|---------------------------|---------|-----|---|
| BIT | NAME | SETTING | DEFAULT | R/W | DESCRIPTION |
| 15 | CNTM_ERR | 1 = error, 0 = no error | 0'b | RO | Error flag of receiver buffer (deskew misalignment) |
| 14 | CNTS_ERR | 1 = error, 0 = no error | 0'b | RO | Error flag of receiver buffer (offset sum error) |
| 13:8 | Reserved | | | | |
| 7 | BIST_ERR_D | 1 = error 0 = no error | 0'b | RO | Error flags for BIST system. |
| 6 | BIST_ERR_C | | 0'b | RO | |
| 5 | BIST_ERR_B | | 0'b | RO | |
| 4 | BIST_ERR_A | | 0'b | RO | |
| 3:0 | Reserved | | | | |

TABLE 3-26. XGMII-SIDE IDLE CODE

| MII REGISTER 27 & 49155, ADDRESSES = 1B'h & C003'h | | | | | |
|--|----------|---------|---------|-----|---|
| BIT | NAME | SETTING | DEFAULT | R/W | DESCRIPTION |
| 15:8 | Reserved | | | | |
| 7:0 | XG_IDLE | | 07'h | R/W | IDLE pattern on XGMII data buses for translation to/from XAUI IDLEs |

TABLE 3-27. EQUALIZATION AND PRE-EMPHASIS CONTROL

| MII REGISTER 28 & 49157, ADDRESSES = 1C'h & C005'h | | | | | |
|--|----------|--|---------|-----|--|
| BIT | NAME | SETTING | DEFAULT | R/W | DESCRIPTION |
| 15:14 | PRE_EMP | 0'h = no pre-emp 1'h = 0.18 pre-emp 2'h = 0.38 pre-emp 3'h = 0.75 pre-emp | 0'h | R/W | Configure the level of pre-emphasis (nominal levels indicated) |
| 13:4 | Reserved | | | | |
| 3:0 | EQ_COEFF | 0'h = no hf boost in equalizer. F'h = boost is maximum | 0'h | R/W | Configuration of the equalizer |

TABLE 3-28. MISCELLANEOUS CONTROL REGISTER 3 (CLAUSE 22)

| MII Register 29, ADDRESS = 1D'h | | | | | |
|---------------------------------|-------------|---------------------------|---------|-----|--|
| BIT | NAME | SETTING | DEFAULT | R/W | DESCRIPTION |
| 15 | Reserved | | | | |
| 14 | XAUI_EN | 1 = enable 0 = disable | 0'b | R/W | Enables all XAUI features per 802.3ae-2002. It is equivalent to setting the following configuration bits (but does not change the actual value of the corresponding MDIO registers' bits): TRANS_EN (reg 10'h bit3) AKR_EN (reg1D'h bit2) A_ALIGN_DIS: 0'b (reg19'h bit1) PCS_SYNC_EN (reg1D'h bit10) DSKW_SM_EN (reg1D'h bit13) ERROR Code = 1FE'h (reg 16'h) |
| 13 | DSKW_SM_EN | 0=disable 1=enable | 0'b | R/W | Enable De-skew state machine control (Note 1). Forced enabled by XAUI_EN. May not operate correctly unless the PCS_SYNC_EN bit is also set. |
| 12:11 | Reserved | | 00'b | | Always write to 00'b |
| 10 | PCS_SYNC_EN | 0=disable 1=enable | 0'b | R/W | Enable 8b/10b PCS coding synchronized state machine (Note 1) to control the byte alignment (IEEE ěcode-group alignment') of the high speed deserializer |

TABLE 3-28. MISCELLANEOUS CONTROL REGISTER 3 (CLAUSE 22) (Continued)

| MII REGISTER 29, ADDRESS = 1D'h | | | | | |
|---------------------------------|---------------------------|--|---------|--------|--|
| BIT | NAME | SETTING | DEFAULT | R/W | DESCRIPTION |
| 9 | TX_SDR | 1 = SDR 0 = DDR | 0'b | R/W | Single data rate on XGMII interface of transmitter. |
| 8 | V _{DDQ} _ASNS_EN | 0=enable 1=disable | 0'b | R/W | Automatically detect V _{DDQ} power supply level and adjust parallel output buffer driving strength. |
| 7 | HSTL_DRIVE | 0=enable 1=disable | 0'b | R/W | Increase parallel output buffer driving strength (if autosense disabled). |
| 6:4 | LOS_CONTROL | 0'h = 160mV _{P-P} 1'h = 240mV _{P-P} 2'h = 200mV _{P-P} 3'h = 120mV _{P-P} 4'h = 80mV _{P-P} else = 160mV _{P-P} | 000'b | R/W | Set the threshold voltage for the Loss Of Signal (LOS) detection circuit. Nominal levels are listed for each control value. Note 2 |
| 3 | SC_RBC | 1=source sync 0=source center | 0'b | R/W | Timing of outgoing Receive Byte Clock (RBC) to Receive data |
| 2 | AKR_EN | 1 = enable random A/K/R 0 = /K/ only | 0'b | R/W | Enable pseudo-random A/K/R (Note 1) in Inter Packet Gap (IPG) on transmitter side (vs. /K/ only) |
| 1 | SOFT_RESET | Write 1 to initiate. | 0'b | R/W SC | Reset the entire chip except MII register settings |
| 0 | Reserved | | | | |

NOTES:

1. These state machines are implemented according to 802.3ae-2002 clause 48.
2. Please refer to section "3.7.2 Loss of Signal (LOS)" on page 6 for a more detailed description.

TABLE 3-29. SPECIAL TEST FUNCTION CONTROL REGISTER

| MII REGISTER 30 & 49159, ADDRESSES = 1E'h & C007'h | | | | | |
|--|----------|---------|---------|-----|--|
| BIT | NAME | SETTING | DEFAULT | R/W | DESCRIPTION |
| 15:0 | reserved | | AAAA'h | R/W | Internal Function. DO NOT ALTER THIS REGISTER in BBT3420 |

TABLE 3-30. HALF RATE CLOCK CONTROL REGISTER

| MII REGISTER 31 & 49160, ADDRESSES = 1F'h & C008'h | | | | | |
|--|------------|-----------------------|---------|-----|---|
| BIT | NAME | SETTING | DEFAULT | R/W | DESCRIPTION |
| 15:4 | reserved | | 0'h | R/W | |
| 3 | HALF_RATED | 1'b = half rate clock | 0'b | R/W | Channel D is running at half-rate clock speed |
| 2 | HALF_RATEC | 1'b = half rate clock | 0'b | R/W | Channel C is running at half-rate clock speed |
| 1 | HALF_RATEB | 1'b = half rate clock | 0'b | R/W | Channel B is running at half-rate clock speed |
| 0 | HALF_RATEA | 1'b = half rate clock | 0'b | R/W | Channel A is running at half-rate clock speed |

TABLE 3-31. LOS STATUS REGISTER (CLAUSE 45)

| MII REGISTER 49161, ADDRESS = C009'h | | | | | |
|--------------------------------------|----------|---|---------|-------------------|--|
| BIT | NAME | SETTING | DEFAULT | R/W | DESCRIPTION |
| 15:8 | Reserved | | | | |
| 7:4 | Internal | | F'h | RO | Internal Function (ignore) |
| 3 | LOS_D | 1 = Signal less than threshold 0 = Signal greater than threshold | 0'b | RO/LH (Note 1) | Loss Of Signal for RX Inputs of each of 4 channels; signal less than LOS_CONTROL value (see Table 3-28 and/or Table 3-33) (Note 2) |
| 2 | LOS_C | | 0'b | | |
| 1 | LOS_B | | 0'b | | |
| 0 | LOS_A | | 0'b | | |

NOTES:

1. These bits are latched high on any LOS condition detected. They are reset low on being read.
2. Please refer to section "3.7.2 Loss of Signal (LOS)" on page 6 for a more detailed description.

TABLE 3-32. MISCELLANEOUS CONTROL REGISTER 1 (CLAUSE 45)

| MII REGISTER 49152, ADDRESS = C000'h | | | | | |
|--------------------------------------|---------------------------|---|---------|-----|---|
| BIT | NAME | SETTING | DEFAULT | R/W | DESCRIPTION |
| 15:14 | Reserved | | 00'b | | Always write to 00'b |
| 13 | V _{DDQ} _ASNS_EN | 0=enable 1=disable | 0'b | R/W | Automatically detect V _{DDQ} power supply level and adjust parallel output buffer driving strength. |
| 12 | HSTL_DRIVE | 0=enable 1=disable | 0'b | R/W | Increase parallel output buffer driving strength (if autosense disabled). |
| 11 | SC_RBC | 1=source sync 0=source center | 0'b | R/W | Timing of outgoing Receive Byte Clock (RBC) to Receive data |
| 10 | CODECENA | 1=enable if CODE pin hi 0=disable | 1'b | R/W | Internal 8b/10b Codec enable/disable |
| 9:8 | CDET[1:0] | Bit 7 controls positive comma detection, Bit 6 controls negative comma detection 0'b=disable 1'b=enable | 11'b | R/W | Comma Detect Select. These bits enable detection of positive, negative, or both positive and negative disparities of comma, or disable detection of either. |
| 7 | DSKW_SM_EN | 0=disable 1=enable | 0'b | R/W | Enable De-skew state machine control (Note 1). Overridden enabled by XAUI_EN; see Table 3-28 and/or Table 3-33. May not operate correctly unless the PCS_SYNC_EN bit is also set. |
| 6:5 | RCLKMODE | See Table 3-22 for a description of these bits, and their interaction with the PSYNC and RETIMER pins. | | | Received Clock Mode. These two bits, together with the PSYNC and RETIMER pins, select which clock the received data is aligned to. |
| 4 | PCS_SYNC_EN | 0=disable 1=enable | 0'b | R/W | Enable 8b/10b PCS coding synchronized state machine (Note 1) to control the byte alignment (IEEE 'code-group alignment') of the high speed deserializer. Overridden enabled by XAUI_EN; see Table 3-28 and/or Table 3-33. |
| 3 | IDLE_D_EN | 1=enabled 0=disabled | 1'b | R/W | Enables IDLE vs. NON-IDLE detection for channel alignment. |
| 2 | ELST_EN | 1=enabled 0=disabled | 1'b | R/W | Enable the elastic function of the receiver buffer |
| 1 | A_ALIGN_DIS | 1=disabled 0=enabled | 1'b | R/W | Receiver aligns data on incoming "VA/" characters (K28.3). If disabled (default), receiver aligns data on IDLE to non-IDLE transitions (if bit 3 set). Overridden enabled by XAUI_EN; see Table 3-28 and/or Table 3-33. |

TABLE 3-32. MISCELLANEOUS CONTROL REGISTER 1 (CLAUSE 45) (Continued)

| MII REGISTER 49152, ADDRESS = C000'h | | | | | |
|--------------------------------------|--------|-------------------------|---------|-----|--|
| BIT | NAME | SETTING | DEFAULT | R/W | DESCRIPTION |
| 0 | CAL_EN | 1=enabled 0=disabled | 1'b | R/W | Enable de-skew calculator of receiver buffer |

NOTE:

1. These state machines are implemented according to 802.3ae-2002 clause 48.

TABLE 3-33. MISCELLANEOUS CONTROL REGISTER 2 (CLAUSE 45)

| MII REGISTER 49153 ADDRESS = C001'h | | | | | |
|-------------------------------------|-------------|--|---------|-----|---|
| BIT | NAME | SETTING | DEFAULT | R/W | DESCRIPTION |
| 15 | SHRT_BIST | 1 = Short BIST Loop pattern 0 = Long BIST Loop pattern | 0'b | R/W | Short is 13458 Byte pattern, Long is 2 ²³ -1 Byte Pattern (plus 9 /K/ "Comma" bytes) |
| 14:13 | Reserved | | | | |
| 12 | BIST_EN | 1 = enable BIST Pattern 0 = disable | 0'b | R/W | Built In Self Test (BIST); may also be enabled by the BIST_EN pin or via the JTAG system. |
| 11 | XAUI_EN | 1 = enable 0 = disable | 0'b | R/W | Enables all XAUI features per 802.3ae-2002. It is equivalent to setting the following configuration bits (but does not change the actual value of the corresponding MDIO registers' bits): TRANS_EN (reg C001'h) AKR_EN (reg1D'h/C001'h) A_ALIGN_DIS: 0'b (reg19'h/C001'h) PCS_SYNC_EN (reg1D'h/C001'h) DSKW_SM_EN (reg1D'h/C001'h) ERROR Code = 1FE'h (reg 16'h) |
| 10:8 | LOS_Control | 0'h = 160mVp-p 1'h = 240mVp-p 2'h = 200mVp-p 3'h = 120mVp-p 4'h = 80mVp-p else = 160mVp-p | 000'b | R/W | Set the threshold voltage for the Loss Of Signal (LOS) detection circuit. Nominal levels are listed for each control value. (Note 2) |
| 7 | SC_TBC | 1=source sync 0=source center | 0'b | R/W | Timing of incoming Transmit Byte Clock (TBC) to transmit data |
| 6 | AKR_EN | 1 = enable pseudo-random A/K/R 0 = /K/ only | 0'b | R/W | Enable pseudo-random A/K/R (Note 1) in Inter Packet Gap (IPG) on transmitter side (vs. /K/ only) |
| 5 | TRANS_EN | 1=enable 0=disable Overridden by XAUI_EN, see bit 11 | 0'b | R/W | This bit enables the transceiver to translate an IDLE pattern in the XGMII data (matching the value of register 1B'h) to and from the XAUI IDLE /K/ comma character or /A/, /K/ & /R/. |
| 4 | IPON | 1=enable 0=disable | 1'b | R/W | Internal Parallel Output Enable |
| 3 | TX_SDR | 1 = SDR 0 = DDR | 0'b | R/W | Single data rate on XGMII interface of transmitter. |
| 2:0 | MF_CTRL | 0 = BIST_ERR 1 = LOS 2 = Reserved 3 = RC[A:D] 4 = TXFIFO_ERR 5 = AFIFO_ERR 6 = EFIFO_ERR | 00'b | R/W | Control the functions of multi-function pins MF[A-D]. RC[A:D]: recovered clock for each channel [A:D]. |

NOTES:

1. These state machines are implemented according to 802.3ae-2002 clause 48.
2. Please refer to section "3.7.2 Loss of Signal (LOS)" on page 6 for a more detailed description.

TABLE 3-34. SOFT RESET CONTROL REGISTER 3 (CLAUSE 45)

| MII REGISTER 49167, ADDRESS = C00F'h | | | | | |
|--------------------------------------|------------|----------------------|---------|--------|--|
| BIT | NAME | SETTING | DEFAULT | R/W | DESCRIPTION |
| 15 | SOFT_RESET | Write 1 to initiate. | 0'b | R/W SC | Reset the entire chip except MII register settings |
| 14:0 | Reserved | | | | |

3.15 JTAG

Five pins – TMS, TCK, TDO, TRST, and TDI – support IEEE Standard 1149.1 JTAG testing. The JTAG test capability has been implemented on all signal pins except the high-speed differential output and input terminals. The following boundary scan operation codes are supported:

TABLE 3-35. JTAG OPERATIONS

| INSTRUCTION | CODE |
|----------------|------|
| Extest | 0000 |
| Sample/Preload | 0001 |
| HighZ | 0010 |
| Clamp | 0011 |
| ID Code | 0100 |
| Bypass | 1111 |
| UDR0 | 1000 |
| UDR1 | 1001 |
| RunBIST | 1010 |

3.15.1 Manufacturers ID

The Manufacturers ID Code returned when reading the ID Code from the JTAG pins is as follows:

V0005351'h,

Where 'V' is an internal 4-bit version number. Consult the Contact Information resources on Page 44 for information as to the meaning of the revision number.

3.15.2 BIST Operation

The Built-In Self Test (BIST) function will only operate correctly if the Encoder/Decoder is enabled (the CODE pin, see Table 4-6, is high, and the CODECENA bit, see Table 3-16 and/or Table 3-32, is set), trunking is turned off to avoid loss of characters to channel alignment, by taking the PSYNC pin low (also see Table 3-22 and/or Table 3-32), and the pseudo-random AKR generation is disabled via the AKR_EN bit, see Table 3-28 and/or Table 3-33. The Pseudo-Random Bit Sequence (PRBS) pattern generator puts out an 8-bit byte-wide pattern, whose length is either $2^{23}-1$ bytes, or 13458 bytes, depending on the value of the SHRT_BIST bit; see Table 3-16 and/or Table 3-33. Either the BIST_EN bit (Table 3-16 and/or Table 3-33) or the BISTEN pin (see Table 4-6 on page 26) causes each Serial Transmitter to put out a sequence of several commas (typically 9), followed by the PRBS pattern as 8-bit data, the sequence then repeating indefinitely, and causes each Serial Receiver to search its incoming bit stream for the same pattern. Once the comma group has set the byte alignment, the BIST error detector will be enabled, and the decoded pattern will then be checked. Any bit error will set the error detector for the corresponding channel. These detectors may be monitored via the MF[A:D] pins (see Table 4-6) and via the MDIO system (see Table 3-25). The detectors may be reset by using SOFT_RESET (see Table 3-28 and/or Table 3-34). The full $2^{23}-1$ byte pattern takes approximately 27ms at 3.125Gbps. Note that certain characterization tests (including generated jitter) can be performed using the PRBS generator, with the 8b/10b Encoder/Decoder disabled, since this will generate a greater variety of Inter Symbol Interference (ISI) patterns than encoded data. However, the checking circuitry will not accept the data as error-free, since the raw pattern will contain many false apparent comma patterns, causing frequent byte realignments, etc.

4 Pin Specifications for BBT3420

The BBT3420 device is packaged in a 289-pin HSPBGA. The terminals are grouped in tables by functionality.

TABLE 4-1. CLOCK PINS

| PIN# | NAME | TYPE | DESCRIPTION |
|---------------|---------------|--------|---|
| J3, J2 | RFCP/RFCN | Input | Differential Reference Input Clock |
| A10 | TCA | Input | Transmit Data Clock, Channels A. The data on TDA(0 - 9) is latched on the rising and falling edges of TCA. When PSYNC is high, TCA acts as the transmit clock for all channels. |
| F16, M16, U10 | TCB, TCC, TCD | Input | Transmit Data Clock, Channels B - D. When PSYNC is low, the data on TDx(0 - 9) is latched on the rising and falling edges of the transmit clocks. When PSYNC is high, these pins are ignored. |
| A11 | RCA | Output | Receive Data Clock, Channels A. The data on RDA(0 - 9) is output on the rising and falling edges of RCA. When PSYNC is high, RCA acts as the receive clock for all channels. |
| F17, M17, U11 | RCB, RCC, RCD | Output | Receive Data Clock, Channels B - D. When PSYNC is low, the data on RDx(0 - 9) is output on the rising and falling edges of the receive clocks. When PSYNC is high, these pins are undefined. |

TABLE 4-2. SERIAL SIDE DATA PINS

| PIN# | NAME | TYPE | DESCRIPTION |
|--------------------------------|--|--------|--|
| D5, D6, F4, G4, M4, L4, P5, P6 | TXAP/TXAN TXBP/TXBN TXCP/TXCN TXDP/TXDN | Output | Transmit Differential Pairs, Channel A - D. CML high-speed serial outputs. |
| B5, B6, F2, G2, M2, L2, T5, T6 | RXAP/RXAN RXBP/RXBN RXCP/RXCN RXDP/RXDN | Input | Receive Differential Pairs, Channel A - D. CML high-speed serial inputs. |

TABLE 4-3. PARALLEL SIDE DATA PINS

| PIN# | NAME | TYPE | DESCRIPTION |
|--|---------------|--------|--|
| C8, B8, A8, E9, D9, C9, E10, D10 | TDA(0-7) | Input | Transmit Data Pins, Channel A. Parallel data on this bus is clocked on the rising and falling edges of TCA. |
| C10 | TDA8 | Input | Transmit Data/ K-code Flag, Channel A. When CODE is low, this pin is the 9th bit of an 8b/10b-encoded/10b-encoded byte to be transmitted. When CODE is high, this pin acts as the K-character generator indicator. When high, this pin causes the data on TDA(0-7) to be encoded into a K-character. Data on this pin is clocked on the rising and falling edges of TCA. |
| B10 | TDA9 | Input | Transmit Data Pin, Channel A. When CODE is low, this pin is the 10th bit of an 8b/10b-encoded byte. When CODE is high, this pin is undefined. Data on this pin is clocked on the rising and falling edges of TCA. |
| C11, B11, E12, D12, C12, C13, B13, A13 | RDA(0-7)(0-7) | Output | Receive Data Pins, Channel A. Parallel data on this bus is valid on the rising and falling edges of RCA. |
| B14 | RDA8 | Output | Receive Data/ K-code Flag, Channel A. When CODE is low, this pin is the 9th bit of a received 8b/10b-encoded byte. When CODE is high, this pin acts as the K-character flag. When high, this indicates the data on RDA(0-7) is a valid K-character. Data on this pin is valid on the rising and falling edges of RCA. |
| A14 | RDA9 | Output | Receive Data Pin/ Error Detect, Channel A. When CODE is low, this pin is the 10th bit of an 8b/10b-encoded byte. When CODE is high, this pin goes high to signify the occurrence of either a parity error or an invalid code word during the decoding of the received data. Data on this pin is valid on the rising and falling edges of RCA. |

TABLE 4-3. PARALLEL SIDE DATA PINS (Continued)

| PIN# | NAME | TYPE | DESCRIPTION |
|--|----------|--------|---|
| F13, F14, F15, G13, G15, G16, H13, H15 | TDB(0-7) | Input | Transmit Data Pins, Channel B. When PSYNC is low, parallel data on this bus is clocked on the rising and falling edges of TCB. When PSYNC is high, data on this bus is clocked on the rising and falling edges of TCA. |
| H16 | TDB8 | Input | Transmit Data/ K-code Flag, Channel B. When PSYNC is low, data on this pin is clocked on the rising and falling edges of TCB. When PSYNC is high, data on this pin is clocked on the rising and falling edges of TCA. When CODE is low, this pin is the 9th bit of an 8b/10b-encoded byte to be transmitted. When CODE is high, this pin acts as the K-character generator indicator. When high, this pin causes the data on TDB(0-7) to be encoded into a K-character. |
| J13 | TDB9 | Input | Transmit Data Pin, Channel B. When PSYNC is low, data on this pin is clocked on the rising and falling edges of TCB. When PSYNC is high, data on this pin is clocked on the rising and falling edges of TCA. When CODE is low, this pin is the 10th bit of an 8b/10b-encoded byte. When CODE is high, this pin is undefined. |
| C14, C15, C16, C17, D13, D15, D16, E13 | RDB(0-7) | Output | Receive Data Pins, Channel B. When PSYNC is low, parallel data on this bus is valid on the rising and falling edges of RCB. When PSYNC is high, data on this bus is valid on the rising and falling edges of RCA. |
| E15 | RDB8 | Output | Receive Data/ K-code Flag, Channel B. When PSYNC is low, data on this pin is valid on the rising and falling edges of RCB. When PSYNC is high, data on this pin is valid on the rising and falling edges of RCA. When CODE is low, this pin is the 9th bit of a received 8b/10b-encoded byte. When CODE is high, this pin acts as the K-character flag. When high, this indicates the data on RDB(0-7) is a valid K-character. |
| E16 | RDB9 | Output | Receive Data Pin/ Error Detect, Channel B. When PSYNC is low, data on this pin is valid on the rising and falling edges of RCB. When PSYNC is high, data on this pin is valid on the rising and falling edges of RCA. When CODE is low, this pin is the 10th bit of an 8b/10b-encoded byte. When CODE is high, this pin goes high to signify the occurrence of either a parity error or an invalid code word during the decoding of the received data. |
| M13, M14, M15, L13, L15, L16, K13, K15 | TDC(0-7) | Input | Transmit Data Pins, Channel C. When PSYNC is low, parallel data on this bus is clocked on the rising and falling edges of TCC. When PSYNC is high, data on this bus is clocked on the rising and falling edges of TCA. |
| K16 | TDC8 | Input | Transmit Data/ K-code Flag, Channel C. When PSYNC is low, data on this pin is clocked on the rising and falling edges of TCC. When PSYNC is high, data on this bus is clocked on the rising and falling edges of TCA. When CODE is low, this pin is the 9th bit of an 8b/10b-encoded byte to be transmitted. When CODE is high, this pin acts as the K-character generator indicator. When high, this pin causes the data on TDC(0-7) to be encoded into a K-character. |
| J15 | TDC9 | Input | Transmit Data Pin, Channel C. When PSYNC is low, data on this pin is clocked on the rising and falling edges of TCC. When CODE is low, this pin is the 10th bit of an 8b/10b-encoded byte. When CODE is high, this pin is undefined. |
| R14, R15, R16, R17, P13, P15, P16, N13 | RDC(0-7) | Output | Receive Data Pins, Channel C. When PSYNC is low, parallel data on this bus is valid on the rising and falling edges of RCC. When PSYNC is high, data on this bus is valid on the rising and falling edges of RCA. |
| N15 | RDC8 | Output | Receive Data/ K-code Flag, Channel C. When PSYNC is low, data on this pin is valid on the rising and falling edges of RCC. When PSYNC is high, data on this pin is valid on the rising and falling edges of RCA. When CODE is low, this pin is the 9th bit of a received 8b/10b-encoded byte. When CODE is high, this pin acts as the K-character flag. When high, this indicates the data on RDC(0-7) is a valid K-character. |
| N16 | RDC9 | Output | Receive Data Pin/ Error Detect, Channel C. When PSYNC is low, data on this pin is clocked on the rising and falling edges of TCC. When CODE is low, this pin is the 10th bit of an 8b/10b-encoded byte. When CODE is high, this pin goes high to signify the occurrence of either a parity error or an invalid code word during the decoding of the received data. |
| R8, T8, U8, N9, P9, R9, N10, P10 | TDD(0-7) | Input | Transmit Data Pins, Channel D. When PSYNC is low, parallel data on this bus is clocked on the rising and falling edges of TCD. When PSYNC is high, data on this bus is clocked on the rising and falling edges of TCA. |

TABLE 4-3. PARALLEL SIDE DATA PINS (Continued)

| PIN# | NAME | TYPE | DESCRIPTION |
|--|----------|--------|---|
| R10 | TDD8 | Input | Transmit Data/ K-code Flag, Channel D. When PSYNC is low, data on this pin is clocked on the rising and falling edges of TCD. When PSYNC is high, data on this bus is clocked on the rising and falling edges of TCA. When CODE is low, this pin is the 9th bit of an 8b/10b-encoded byte to be transmitted. When CODE is high, this pin acts as the K-character generator indicator. When high, this pin causes the data on TDD(0-7) to be encoded into a K-character. |
| T10 | TDD9 | Input | Transmit Data Pin, Channel D. When PSYNC is low, data on this pin is clocked on the rising and falling edges of TCD. When PSYNC is high, data on this bus is clocked on the rising and falling edges of TCA. When CODE is low, this pin is the 10th bit of an 8b/10b-encoded byte. When CODE is high, this pin is undefined. |
| R11, T11, N12, P12, R12, R13, T13, U13 | RDD(0-7) | Output | Receive Data Pins, Channel D. When PSYNC is low, parallel data on this bus is valid on the rising and falling edges of RCD. When PSYNC is high, data on this bus is valid on the rising and falling edges of RCA. |
| T14 | RDD8 | Output | Receive Data/ K-code Flag, Channel D. When PSYNC is low, data on this pin is valid on the rising and falling edges of RCD. When PSYNC is high, data on this pin is valid on the rising and falling edges of RCA. When CODE is low, this pin is the 9th bit of a received 8b/10b-encoded byte. When CODE is high, this pin acts as the K-character flag. When high, this indicates the data on RDD(0-7) is a valid K-character. |
| U14 | RDD9 | Output | Receive Data Pin/ Error Detect, Channel D. When PSYNC is low, data on this pin is valid on the rising and falling edges of RCD. When CODE is low, this pin is the 10th bit of an 8b/10b-encoded byte. When CODE is high, this pin goes high when to signify the occurrence of either a parity error or an invalid code word during the decoding of the received data. |

TABLE 4-4. JTAG INTERFACE

| PIN# | NAME | TYPE | DESCRIPTION |
|------|-------|-----------------------|------------------|
| B3 | TDI | Input (w/pullup) | JTAG Input Data |
| A2 | TDO | Output | JTAG Output Data |
| B2 | TMS | Input (w/pullup) | JTAG Mode Select |
| A3 | TCLK | Input (w/pulldown) | JTAG Clock |
| A1 | TRSTN | Input (w/pullup) | JTAG Reset |

TABLE 4-5. MANAGEMENT DATA INTERFACE

| PIN# | NAME | TYPE | DESCRIPTION |
|--------------------|-----------|-------|---|
| U3 | MDIO | I/O | Management Address/Data I/O |
| U2 | MDC | Input | Management Interface Clock |
| R1, T1, T3, T2, R2 | PADR(0-4) | Input | Management Address (PHYAD for Clause 22, PRTAD for Clause 45). See also MFD & MFC in next table for DEVAD control in Clause 45. |

TABLE 4-6. MISCELLANEOUS PINS

| PIN# | NAME | TYPE | DESCRIPTION |
|--------------------|------------------|--|---|
| P1 | CODE | Input (w/pullup) | Encode Enable, When CODE is high, the 8b/10b encoder and decoder are enabled, provided the CODECENA bit is set, see Table 3-16 and/or Table 3-32. When CODE is low, the encoder and decoder are disabled, and the Parallel side handles raw 10b data. |
| A16, B16, T16, U16 | MF[A:D] | Output (MFC and MFD are inputs w/pullup during reset). | Multi-function I/O's, Channels [A:D]. The functions of these pins are enabled via the MDIO. Currently defined functions are: ² FIFO_ERR for each channel, for TX, Align and Elasticity FIFOs. LOS (Loss of Signal) for each channel, ² RC[A:D]: Recovered clock outputs ² COMMA_DET (K28.5 character detected) for each channel, and ² BIST_ERR (Built-In Self Test Pseudo Random Bit Stream Test Status) for each channel. The default condition for these pins is BIST_ERR. See Table 3-15 and/or Table 3-33 for further details. MFC and MFD are also used as inputs during reset, to control the MDIO interface DEVAD value, see Table 3-5. |
| C1 | PSYNC | Input (w/pulldown) | Channel Synchronization Enable. When PSYNC is high, all transmit data is latched on the rising and falling edges of TCA, all receive data is valid on the rising and falling edges of RCA. |
| B1 | RSTN | Input | Chip Reset (FIFO Clear) |
| C3, D3, P3, R3 | LPEN(A-D) | Input (w/pulldown) | Loop Enable, Channels A-D. When high, the serial output for each channel is looped back to its input. |
| D1 | SIG_DET | Output | SIG_DET. This pin is asserted when all four Signal Detectors detect signal levels above the threshold (see Table 3-28 and/or Table 3-33). |
| U1 | RSVN/ RETIMER | Input (w/pullup) | Active Low If low, the BBT3420 acts as a Retimer device, rather than a transceiver (SerDes) device. |
| P2 | BISTEN | Input (w/pulldown) | Built-In Self Test Enable--Active High. When high, enables internal 23-bit PRBS test function. |

TABLE 4-7. VOLTAGE SUPPLY AND REFERENCE PINS

| PIN# | NAME | TYPE | DESCRIPTION |
|---|------------------|---------------|--|
| J17 | V _{REF} | Input | Parallel Side Input Voltage Reference |
| C2 | REFP | Input | When REFP pin is tied to V _{DDQ} , MF[A-D] are the receiver complementary clock outputs MFA = RCANMFB = RCBNMFC = RCCNMFD = RCDN When REFP pin is left as no-connect or tied to low, MF[A-D] are the multi-function I/O's as defined in Table 4-6 |
| D2 | REFN | Input | No Connect Terminal (internal inactive resistor for test purposes.) |
| J1 | RREF | Input | Additional Resistor Terminal (N.C.) |
| A9, A12, A15, A17, D8, D11, D14, D17, G14, G17, J14, J16, L14, L17, P8, P11, P14, P17, U9, U12, U15, U17 | V _{DDQ} | Supply | Control and Parallel Input/Output Supply Voltage |
| D4, D7, E4, H1, H4, J4, K1, K4, N4, P4, P7 | VDD | Supply | Internal (Core) Supply |
| A5, A6, A7, C5, C6, F1, F3, G1, G3, L1, L3, M1, M3, R5, R6, U5, U6, U7 | VDDA | Analog Supply | Analog Supply. Should be decoupled from VDD |
| B9, B12, B15, B17, E5, E6, E7, E8, E11, E14, E17, H2, H3, H5, H14, H17, J5, K2, K3, K5, K14, K17, N5, N6, N7, N8, N11, N14, N17, T9, T12, T15, T17 | GND | Ground | Ground for Core, Control and Parallel Input/Outputs. |
| A4, B4, B7, C4, C7, E1, E2, E3, F5, G5, L5, M5, N1, N2, N3, R4, R7, T4, T7, U4 | GNDA | Analog Ground | Analog Ground. Should be connected to GND at one point. |
| F6, F7, F8, F9, F10, F11, F12, G6, G7, G8, G9, G10, G11, G12, H6, H7, H8, H9, H10, H11, H12, J6, J7, J8, J9, J10, J11, J12, K6, K7, K8, K9, K10, K11, K12, L6, L7, L8, L9, L10, L11, L12, M6, M7, M8, M9, M10, M11, M12 | T-GND | Ground | Thermal Grounds. Electrically tied to Ground, but used to improve thermal transfer to mounting medium (PCB). |

4.1 Pin Diagram for BBT3420 (Top View)

| | A | B | C | D | E | F | G | H | J | K | L | M | N | P | R | T | U | |
|----|-------|------|-------|---------|------|-------|-------|-------|-------|-------|-------|-------|------|---------|-------|-------|------|----|
| 17 | VDDQ | GND | RDB3 | VDDQ | GND | RCB | VDDQ | GND | VREF | GND | VDDQ | RCC | GND | VDDQ | RDC3 | GND | VDDQ | 17 |
| 16 | MFA | MFB | RDB2 | RDB6 | RDB9 | TCB | TDB5 | TDB8 | VDDQ | TDC8 | TDC5 | TCC | RDC9 | RDC6 | RDC2 | MFC | MFD | 16 |
| 15 | VDDQ | GND | RDB1 | RDB5 | RDB8 | TDB2 | TDB4 | TDB7 | TDC9 | TDC7 | TDC4 | TDC2 | RDC8 | RDC5 | RDC1 | GND | VDDQ | 15 |
| 14 | RDA9 | RDA8 | RDB0 | VDDQ | GND | TDB1 | VDDQ | GND | VDDQ | GND | VDDQ | TDC1 | GND | VDDQ | RDC0 | RDD8 | RDD9 | 14 |
| 13 | RDA7 | RDA6 | RDA5 | RDB4 | RDB7 | TDB0 | TDB3 | TDB6 | TDB9 | TDC6 | TDC3 | TDC0 | RDC7 | RDC4 | RDD5 | RDD6 | RDD7 | 13 |
| 12 | VDDQ | GND | RDA4 | RDA3 | RDA2 | T-GND | T-GND | T-GND | T-GND | T-GND | T-GND | T-GND | RDD2 | RDD3 | RDD4 | GND | VDDQ | 12 |
| 11 | RCA | RDA1 | RDA0 | VDDQ | GND | T-GND | T-GND | T-GND | T-GND | T-GND | T-GND | T-GND | GND | VDDQ | RDD0 | RDD1 | RCD | 11 |
| 10 | TCA | TDA9 | TDA8 | TDA7 | TDA6 | T-GND | T-GND | T-GND | T-GND | T-GND | T-GND | T-GND | TDD6 | TDD7 | TDD8 | TDD9 | TC | 10 |
| 9 | VDDQ | GND | TDA5 | TDA4 | TDA3 | T-GND | T-GND | T-GND | T-GND | T-GND | T-GND | T-GND | TDD3 | TDD4 | TDD5 | GND | VDDQ | 9 |
| 8 | TDA2 | TDA1 | TDA0 | VDDQ | GND | T-GND | T-GND | T-GND | T-GND | T-GND | T-GND | T-GND | GND | VDDQ | TDD0 | TDD1 | TDD2 | 8 |
| 7 | VDDA | GND | GND | VDD | GND | T-GND | T-GND | T-GND | T-GND | T-GND | T-GND | T-GND | GND | VDD | GND | GND | VDDA | 7 |
| 6 | VDDA | RXAN | VDDA | TXAN | GND | T-GND | T-GND | T-GND | T-GND | T-GND | T-GND | T-GND | GND | TXDN | VDDA | RXDN | VDDA | 6 |
| 5 | VDDA | RXAP | VDDA | TXAP | GND | GND | GND | GND | GND | GND | GND | GND | GND | TXDP | VDDA | RXDP | VDDA | 5 |
| 4 | GND | GND | GND | VDD | VDD | TXBP | TXBN | VDD | VDD | VDD | TXCN | TXCP | VDD | VDD | GND | GND | GND | 4 |
| 3 | TCLK | TDI | LPENA | LPENB | GND | VDDA | VDDA | GND | RFCP | GND | VDDA | VDDA | GND | LPENC | LPEND | PADR2 | MDIO | 3 |
| 2 | TDO | TMS | REFP | REFN | GND | RXBP | RXBN | GND | RFCN | GND | RXCN | RXCP | GND | BIST EN | PADR4 | PADR3 | MDC | 2 |
| 1 | TRSTN | RSTN | PSYNC | SIG_DET | GND | VDDA | VDDA | VDD | RREF | VDD | VDDA | VDDA | GND | CODE | PADR0 | PADR1 | RSVN | 1 |

FIGURE 4-1. BBT3420 PACKAGE PIN OUT DIAGRAM

5 Package Dimensions

All linear dimensions in the below mechanical drawing of the BBT3420 package are in millimeters.

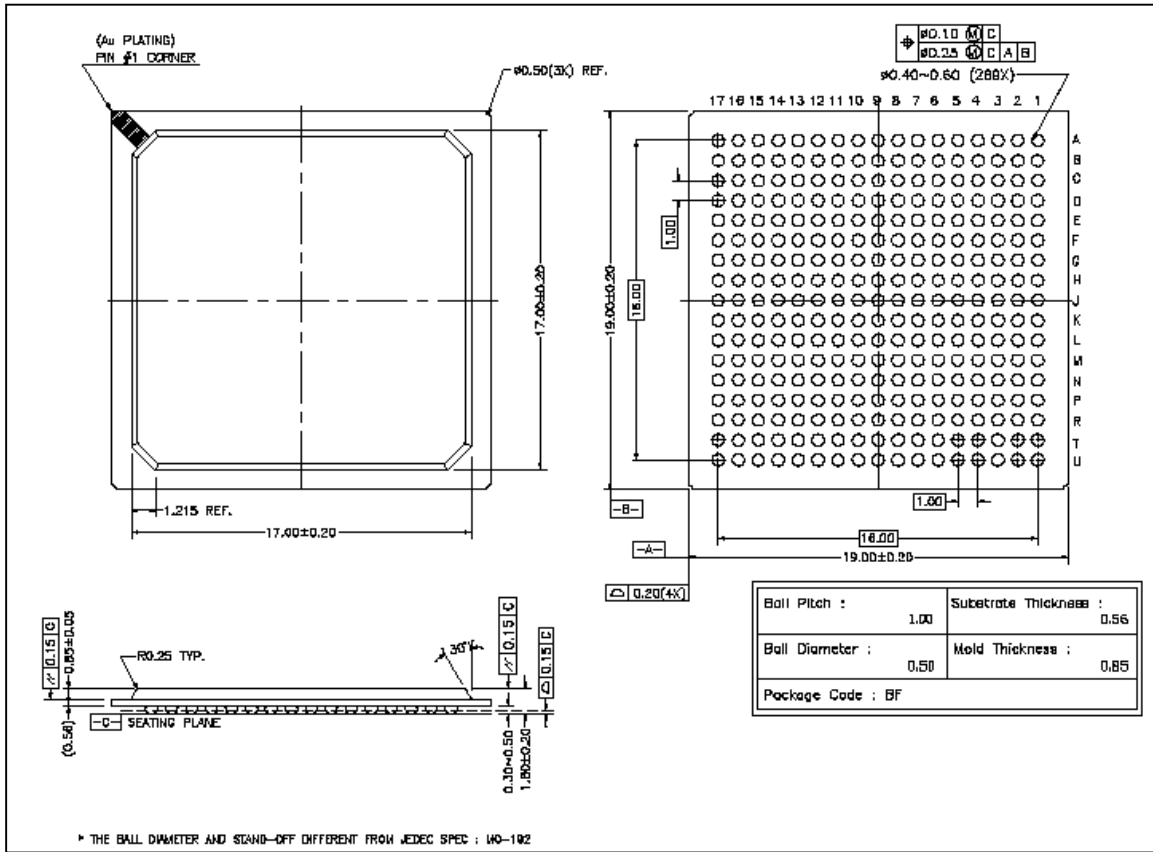

FIGURE 5-1. HSBGA-289 PACKAGE DIMENSIONS

6 Electrical Characteristics

6.1 Absolute Maximum Ratings

TABLE 6-1. ABSOLUTE MAXIMUM RATINGS

| SYMBOL | PARAMETER | UNITS | MIN | MAX |
|------------------------------------|-----------------------------------|-------|-------|-----------------------|
| V _{DDQ} | Parallel I/O Power Supply Voltage | V | -0.5 | 4.6 |
| V _{DDA} , V _{DD} | Other Power Supply Voltages | V | -0.5 | 2.5 |
| V _{INCML} | CML DC Input Voltage | V | -0.5 | V _{DD} + 0.5 |
| V _{INXSTTL} | HSTL/SSTL_2 DC Input Voltage | V | -0.5 | 5.5 |
| I _{OUTCML} | CML Output Current | mA | -50 | |
| I _{OUXSTTL} | HSTL/SSTL_2 Output Current | mA | | 50 |
| T _{STG} | Storage Temperature | °C | -65 | 150 |
| T _J | Junction Temperature | °C | -55 | 125 |
| T _{SOL} | Soldering Temperature (10s) | °C | | 220 |
| V _{ESD} | Maximum Input ESD (HBM) | V | -1500 | 1500 |

These ratings are those which if exceeded may cause permanent damage to the device. Operation at these or any other conditions in excess of those listed under Operating Conditions below is not implied. Continued exposure to these ratings may reduce device reliability.

6.2 Operating Conditions

All specifications assume T_A = 0°C to +70°C, V_{DD} = V_{DDA} = 1.8 ± 0.1V, V_{DDQ} = 2.5 ± 0.2V, unless otherwise specified.

TABLE 6-2. RECOMMENDED OPERATING CONDITIONS

| SYMBOL | PARAMETER | UNITS | MIN | NOM | MAX |
|------------------------------------|---|-------|------|-----|-----|
| V _{DDA} & V _{DD} | Core and Serial I/O Power Supply Voltages | V | 1.7 | 1.8 | 1.9 |
| V _{DDQ} | Parallel I/O Power Supply Voltage | V | +1.7 | | 2.7 |
| T _A | Ambient Operating Temperature | °C | 0 | 25 | 70 |

TABLE 6-3. THERMAL RESISTANCES

| SYMBOL | PARAMETER | UNIT | TYP | MAX |
|-----------------|--------------------------------------|------|-----|-----|
| θ _{JC} | Thermal Resistance, Junction to Case | °C/W | 14 | |
| θ _{CA} | Thermal Resistance, Case to Ambient | °C/W | 19 | |

TABLE 6-4. SERIAL PIN I/O ELECTRICAL SPECIFICATIONS

| SYMBOL | PARAMETER | UNITS | MIN | TYP | MAX |
|---------------------|--|-------|------|------|------|
| V _{P-PIN} | Peak-To-Peak Differential Voltage Input Requirement (Note 1) | mV | 200 | | |
| V _{P-POUT} | Peak-To-Peak Differential Voltage Output Amplitude (Z _O = 100Ω differential load) no Pre-emphasis | mV | 1000 | 1300 | 1800 |

NOTE:

1. Applies for DC balanced data such as XAUI 8B/10B data. For data with long run lengths such as PRBS, DC offset compensation circuitry must be turned off. The device default is for DC offset compensation circuitry to be turned on. See Table 3-17.

TABLE 6-5. PARALLEL PIN I/O CHARACTERISTICS, SSTL_2 (Class I, see Figure 2-1)

| SYMBOL | PARAMETER | UNITS | MIN | TYP | MAX |
|---------------------|---------------------|-------|-------------------------|------------------|-------------------------|
| V _{DDQ} | Supply Voltage | V | 2.3 | 2.5 | 2.7 |
| V _{REF} | Reference Voltage | V | 1.15 | 1.25 | 1.35 |
| V _{TT} | Termination Voltage | V | V _{REF} - 0.04 | V _{REF} | V _{REF} + 0.04 |
| V _{IH(dc)} | dc input logic high | V | V _{REF} + 0.18 | | V _{DDQ} + 0.3 |

TABLE 6-5. PARALLEL PIN I/O CHARACTERISTICS, SSTL_2 (Class I, see Figure 2-1)

| SYMBOL | PARAMETER | UNITS | MIN | TYP | MAX |
|--------------|---|-------|------------------|-----|------------------|
| $V_{IL(dc)}$ | dc input logic low | V | -0.3 | | $V_{REF} - 0.18$ |
| $V_{IH(ac)}$ | ac input logic high | V | $V_{REF} + 0.35$ | | |
| $V_{IL(ac)}$ | ac input logic low | V | | | $V_{REF} - 0.35$ |
| V_{OH} | dc output logic high ($I_{OH} = 7.6mA$) | V | $V_{DDQ} - 0.62$ | | |
| V_{OL} | dc output logic low ($I_{OL} = 7.6mA$) | V | | | 0.54 |
| $V_{OH(ac)}$ | ac output logic high ($I_{OH} = 8mA$) | V | $V_{DDQ} - 0.5$ | | |
| $V_{OL(ac)}$ | ac output logic low ($I_{OL} = 8mA$) | V | | | 0.5 |

TABLE 6-6. PARALLEL PIN I/O CHARACTERISTICS, HSTL ($V_{DDQ} = 1.8V \pm 0.1V$) (Class I, see Figure 2-1)

| SYMBOL | PARAMETER | UNITS | MIN | TYP | MAX |
|--------------|---|-------|-----------------|----------------------|-----------------|
| V_{DDQ} | Supply Voltage | V | 1.7 | 1.8 | 1.9 |
| V_{REF} | Reference Voltage | V | 0.83 | 0.9 | 1.07 |
| V_{TT} | Termination Voltage | V | | $V_{DDQ} \times 0.5$ | |
| $V_{IH(dc)}$ | dc input logic high | V | $V_{REF} + 0.1$ | | $V_{DDQ} + 0.3$ |
| $V_{IL(dc)}$ | dc input logic low | V | -0.3 | | $V_{REF} - 0.1$ |
| $V_{IH(ac)}$ | ac input logic high | V | $V_{REF} + 0.2$ | | |
| $V_{IL(ac)}$ | ac input logic low | V | | | $V_{REF} - 0.2$ |
| $V_{OH(dc)}$ | dc output logic high ($I_{OH} = 8mA$) | V | $V_{DDQ} - 0.4$ | | $V_{DDQ} + 0.3$ |
| $V_{OL(dc)}$ | dc output logic low ($I_{OL} = 8mA$) | V | | | 0.4 |
| $V_{OH(ac)}$ | ac output logic high ($I_{OH} = 8mA$) | V | $V_{DDQ} - 0.5$ | | |
| $V_{OL(ac)}$ | ac output logic low ($I_{OL} = 8mA$) | V | | | 0.5 |

TABLE 6-7. OTHER DC ELECTRICAL SPECIFICATIONS

| SYMBOL | PARAMETER | | UNITS | MIN | TYP |
|--------------------|--|------------------|---------|----------------------|-----|
| $V_{IH, CTL}$ | Control Input High Voltage Range | $V_{DDQ} = 1.8$ | V | $V_{DDQ} \times 0.7$ | |
| | | $V_{DDQ} = 2.5V$ | | 1.7 | |
| $V_{IL, CTL}$ | Control Input Low Voltage Range | $V_{DDQ} = 1.8$ | V | -0.3 | |
| | | $V_{DDQ} = 2.5V$ | | | |
| $V_{OH, CTL}$ | Status Output High Voltage Level $I_{OH} = -1mA$ | | V | $V_{DDQ} - 0.4$ | |
| $V_{OL, CTL}$ | Status Output Low Voltage Level $I_{OL} = 1mA$ | | V | 0 | |
| $I_{IH, CTL}$ | Input High Current (Magnitude), $V_{IN} = 2.4V$ | | μA | | |
| $I_{IL, CTL}$ | Input Low Current (Magnitude), $V_{IN} = 0.5V$ | | μA | | |
| $I_{DD} + I_{DDA}$ | Total Core Supply Current (includes high-speed I/Os), $T_A = 25^\circ C$ | | mA | | 600 |
| I_{DDQ-NL} | I/O Supply Current, $T_A = 25^\circ C$ (no loading) | | mA | | TBD |
| I_{DDQ} | I/O Supply Current, $T_A = 25^\circ C$ (50 Ω load) | | mA | | TBD |

6-3 Timing Characteristics

All specifications assume $T_A = 0^\circ\text{C}$ to $+70^\circ\text{C}$, $V_{DD} = V_{DDA} = 1.8 \pm 0.1\text{V}$, $V_{DDQ} = 2.5 \pm 0.2\text{V}$, unless otherwise specified.

TABLE 6-8. TRANSMIT PARALLEL INTERFACE TIMING (see Figure 6-1 & Figure 6-2)

| SYMBOL | PARAMETER | MIN | TYP | MAX | UNIT |
|---------------------------|---|-----|-----|-----|------|
| T_{SU} | Setup Time | 0.4 | | | ns |
| T_{HOLD} | Hold Time | 0.4 | | | ns |
| TT_{LAT} (codec) | Transmitter latency with encoder enabled | | 65 | 70 | UI |
| TT_{LAT} (raw) | Transmitter latency with encoder disabled | | 55 | 65 | UI |

TABLE 6-9. RECEIVE PARALLEL INTERFACE TIMING (see Figure 6-3 through Figure 6-6)

| SYMBOL | PARAMETER | MIN | TYP | MAX | UNIT |
|---------------------------|---|------|---------|------|-------|
| RT_{SYNC} | Bit Sync Time | | | 2500 | Bits |
| T_{DVCC} | Time data valid before the rising edge or falling edge of the alignment clock | 0.96 | | | ns |
| T_{CCDV} | Time data valid after the rising or falling edge of the alignment clock | 0.96 | | | ns |
| RT_{LAT} (codec) | Receiver latency with encoder enabled | 55 | 125 | 195 | UI |
| RT_{LAT} (raw) | Receiver latency with encoder disabled | 45 | 115 | 185 | Bits |
| RT_{SKEWIN} | Input skew between channels in trunking mode1 | | ± 3 | | Bytes |

NOTE:

1. RT_{SKEWIN} is defined as input skew to BBT3420 high speed input receiver.

TABLE 6-10. REFERENCE CLOCK REQUIREMENTS

| SYMBOL | PARAMETER | MIN | TYP | MAX | UNIT |
|-----------------------|------------------------------------|-------|-----|---------|------|
| $1/T_{\text{REFCLK}}$ | Ref clock frequency range (Note 1) | 124.4 | | 159.375 | MHz |
| T_{JREF} | Ref clock frequency offset | -100 | | 100 | ppm |
| Refduty | Ref clock duty cycle | 45 | 50 | 55 | % |

NOTE:

1. System requirements are normally much more restrictive, typically $\pm 100\text{ppm}$. This specification refers to the range over which the BBT3420 will operate.

TABLE 6-11. TRANSMIT SERIAL DIFFERENTIAL OUTPUT TIMING (see Figure 6-12)

| SYMBOL | PARAMETER | MIN | TYP | MAX |
|--------------------|---|--------------------|-----|-----|
| T_{ODR} | Rise time (20%-80%) | | 100 | 130 |
| T_{ODF} | Fall time (20%-80%) | | 100 | 130 |
| T_{OCCDS} | Channel to Channel Differential Skew (Note 1) | | | 15 |
| TX_{JIT} | Random Jitter (RMS, 1100 pattern) (Note 2) | 2.488Gbps | 2 | 4 |
| | | 3.125Gbps | 2.5 | 4 |
| | | 3.1875Gbps | 2.5 | 4 |
| | Total Jitter (RMS, encoded BIST pattern) | 2.488Gbps | | 8 |
| | | 3.125Gbps (Note 3) | 6 | 8 |
| | 3.1875Gbps | | 8 | |

NOTES:

1. Parameter is guaranteed by design.
2. Strictly the 1010 pattern causes a small additional non-random jitter, so that the true random jitter is slightly less than that shown.
3. Max jitter for CJPAT pattern is around 10ps.

TABLE 6-12. SERIAL DIFFERENTIAL INPUT TIMING REQUIREMENTS (see Figure 6-12)

| SYMBOL | PARAMETER | MIN | TYP | MAX | UNIT |
|-----------------|-----------------------------------|------|-----|-----|------|
| T _{DJ} | Deterministic Jitter (Notes 1, 2) | 0.7 | | | UI |
| T _{Jl} | Total jitter tolerance | 0.88 | | | UI |

NOTES:

- Jitter specifications include all but 10⁻¹² of the jitter population.
- Near end driven by BBT3420 Tx.

TABLE 6-13. RESET AND DEVD FROM MFD, MFC TIMING (see Figure 6-9)

| SYMBOL | PARAMETER | MIN | TYP | MAX | UNIT |
|---------------------|--------------------------------|-----|-----|-----|---------------------|
| T _{RESET} | RSTN Active width | 10 | | | μs |
| T _{RSTDVS} | Setup from MFD, MFC to RSTN | 2 | | | μs |
| T _{RSTDVH} | Hold from RSTN to MFD, MFC | 1 | | | T _{REFCLK} |
| T _{RSTMV} | Delay from RSTN to MFD/C Valid | 2 | | | T _{REFCLK} |

TABLE 6-14. MDIO INTERFACE TIMING (from IEEE802.3ae-2002) (see Figure 6-10)

| SYMBOL | PARAMETER | MIN | TYP | MAX | UNIT |
|---------------------|----------------------------------|-----|-----|-----|------|
| T _{MDCD} | BBT3420 MDIO out delay from MDC | 0 | | 300 | ns |
| T _{MDS} | Setup from MDIO in to MDC | 10 | | | ns |
| T _{RSTDVH} | Hold from MDC to MDIO in | 10 | | | ns |
| T _{RSTMV} | Clock Period MDC (Note 1) | 50 | 400 | | ns |
| | MDC Clock HI or LO time (Note 1) | 20 | 160 | | ns |

NOTE:

- The BBT3420 will accept a much higher MDC clock rate and shorter HI and LO times than the IEEE802.3ae specification (section 22.2.2.11) requires. Such a faster clock may not be acceptable to other devices on the interface.

TABLE 6-15. RESET AND BISTEN TIMING (see Figure 6-11)

| SYMBOL | PARAMETER | MIN | TYP | MAX | UNIT |
|----------------------|--|-----|-----|-----|---------------------|
| T _{RESET} | RSTN Active width | 10 | | | μs |
| T _{RSTBIST} | Delay from RSTN to BISTEN | 2 | | | T _{REFCLK} |
| T _{BRST} | BISTEN Inactive width | 20 | | | T _{REFCLK} |
| T _{BRVD} | Delay from BISTEN to valid ERR (MFA-D) Value | | | | T _{REFCLK} |

6.4 Timing Diagrams

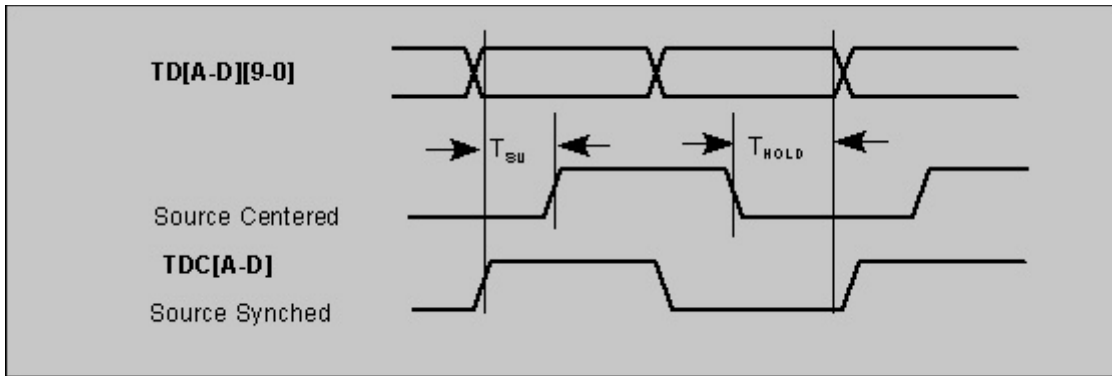

FIGURE 6-1. TRANSMITTER PARALLEL TIMING

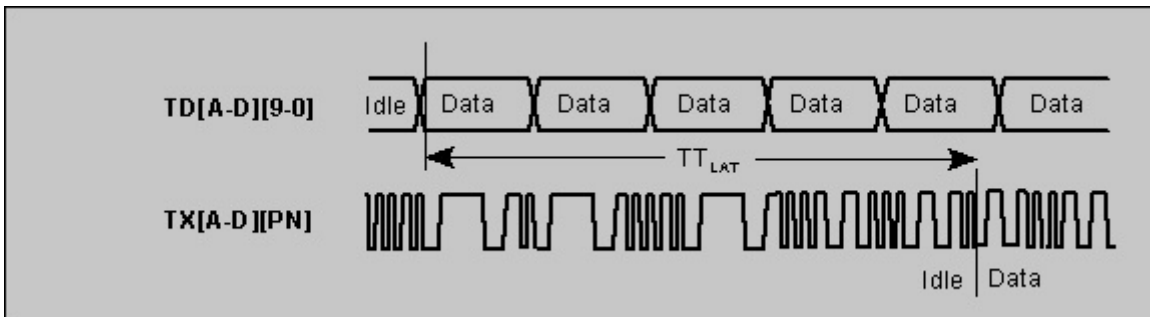

FIGURE 6-2. TRANSMITTER LATENCY

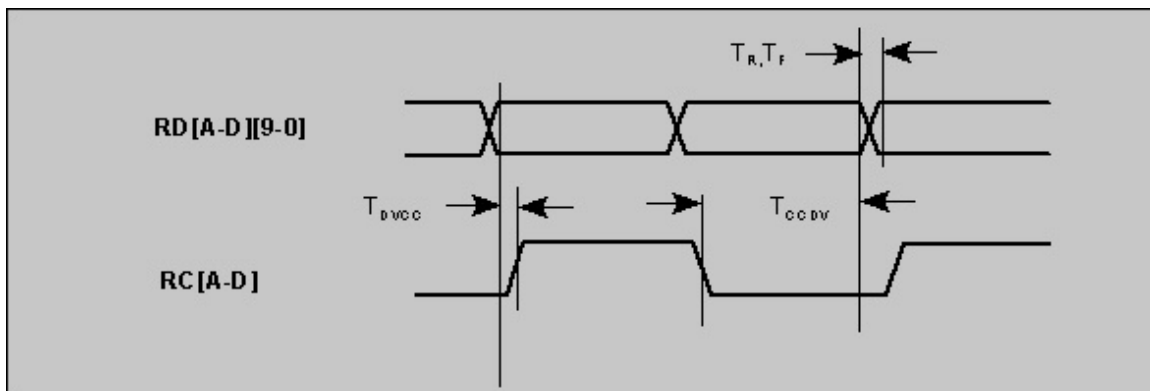

FIGURE 6-3. RECEIVER PARALLEL DATA TIMING

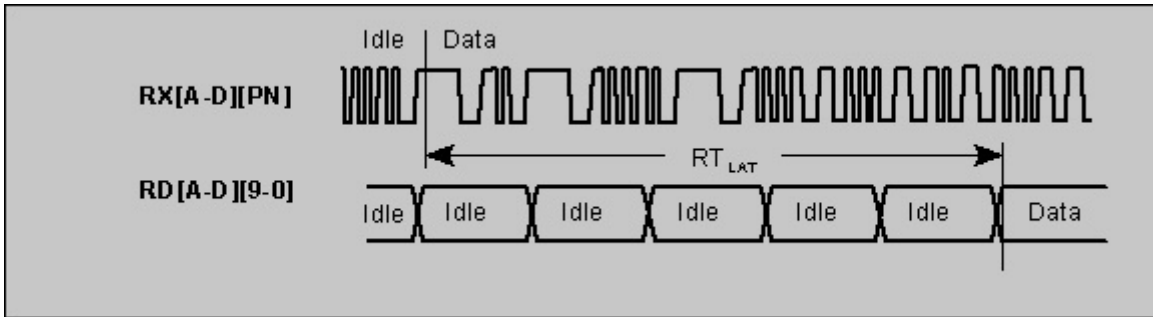

FIGURE 6-4. RECEIVER LATENCY

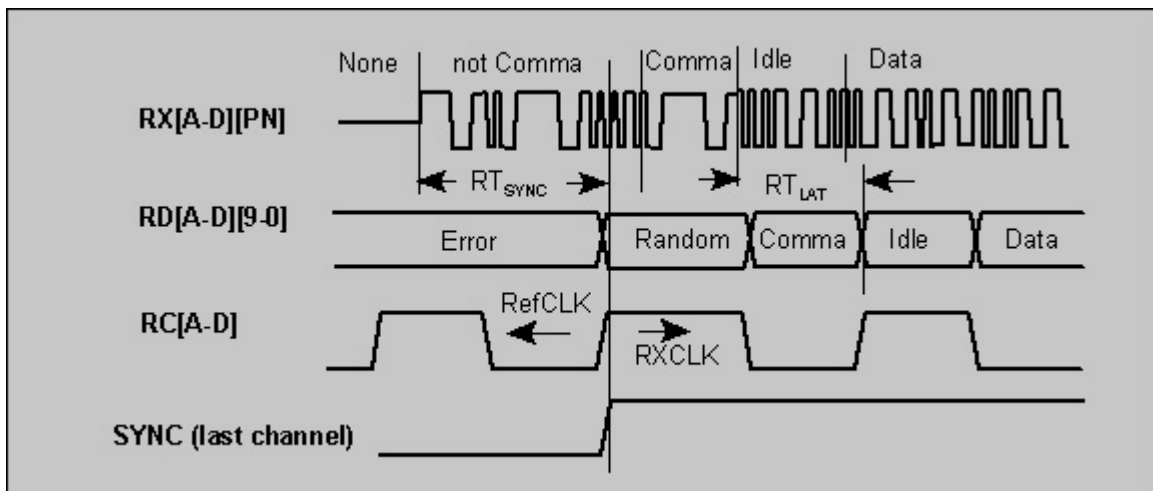

FIGURE 6-5. BYTE SYNCHRONIZATION

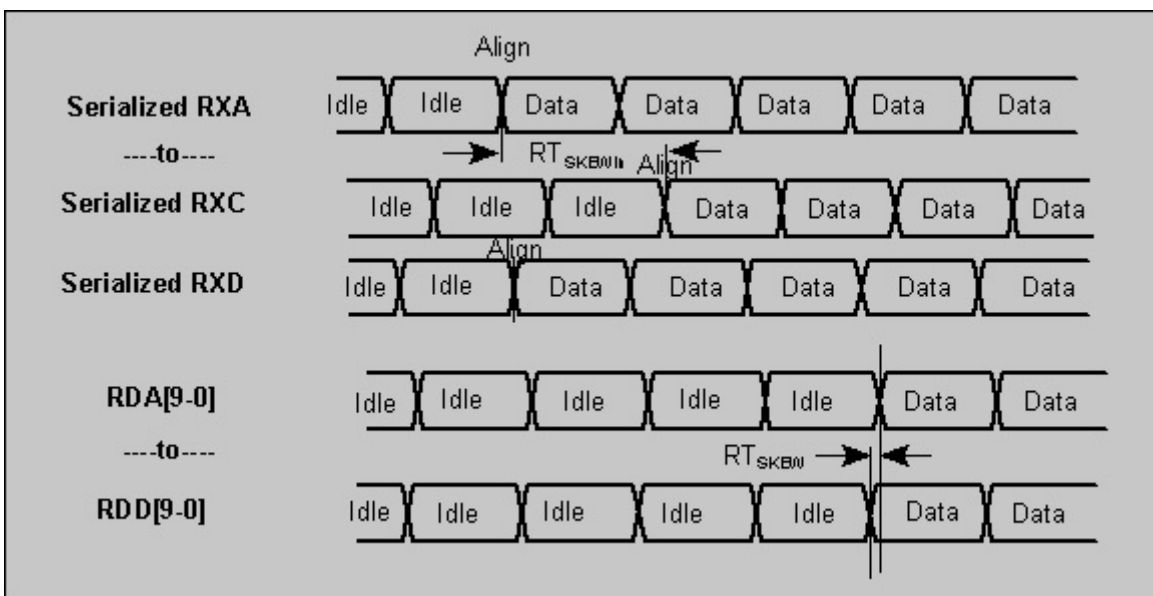

FIGURE 6-6. CHANNEL ALIGNMENT OPERATION

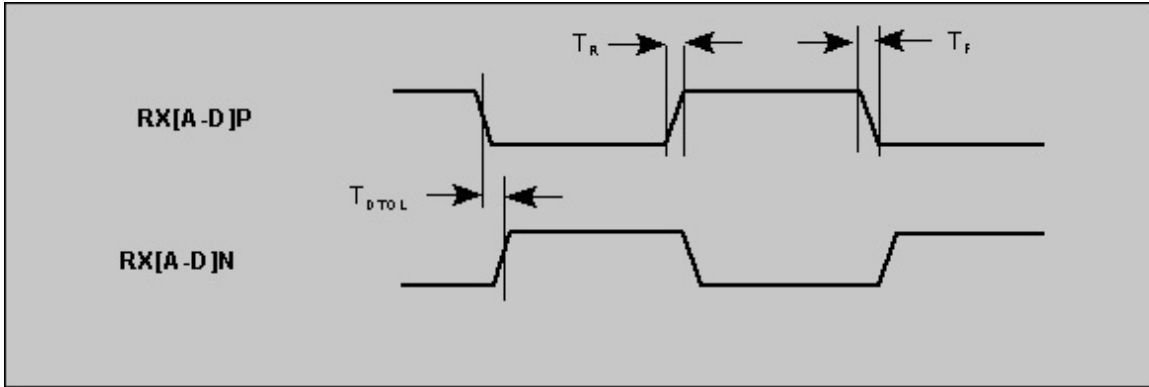

FIGURE 6-7. DIFFERENTIAL SIGNAL TIMING

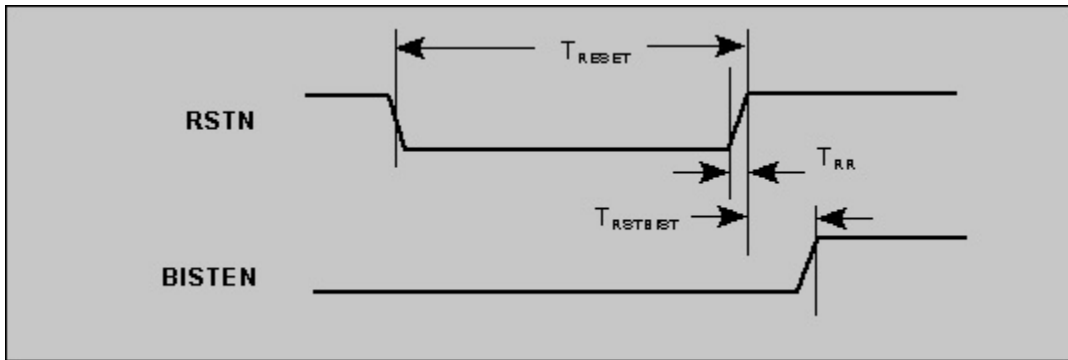

FIGURE 6-8. RESET AND BIST ENABLE TIMING

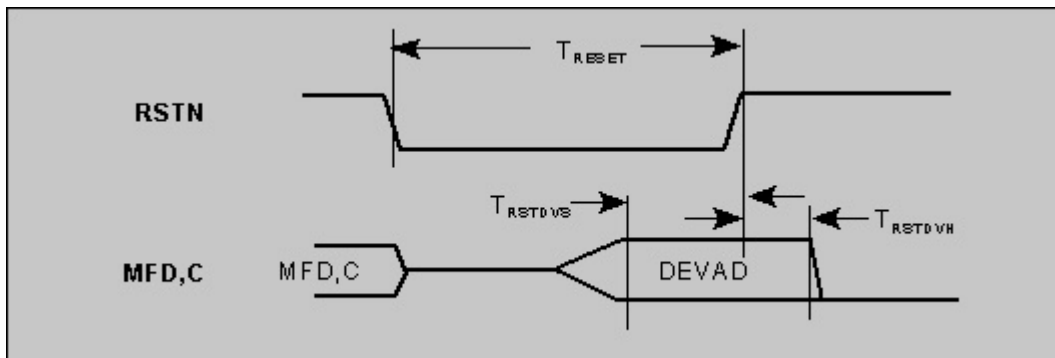

FIGURE 6-9. SETTING DEVAD AT END OF RESET

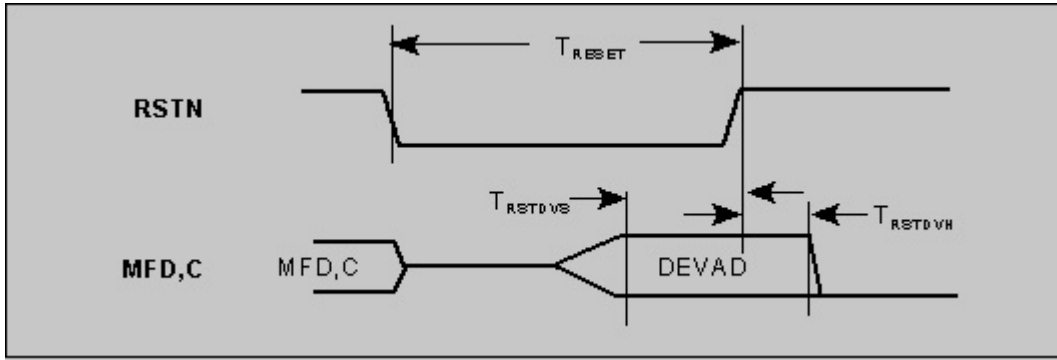

FIGURE 6-10. MDIO INTERFACE TIMING

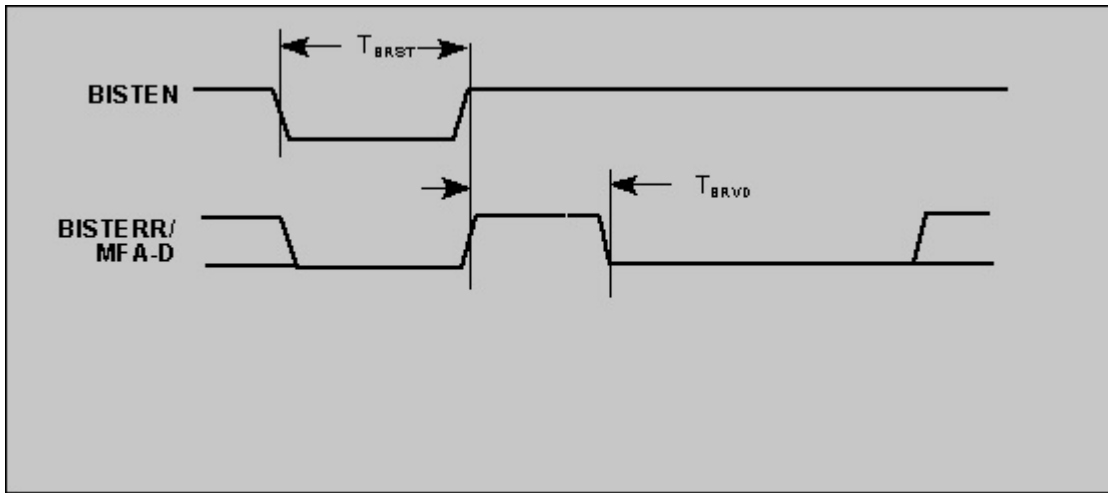

FIGURE 6-11. BIST ERROR FLAG TIMING

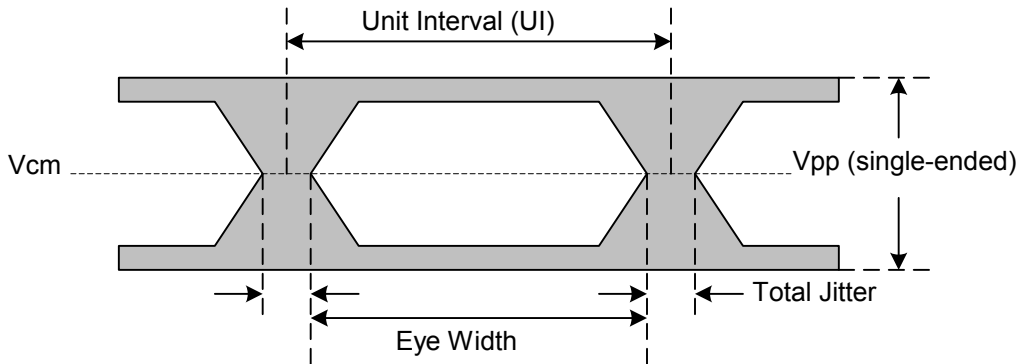

FIGURE 6-12. EYE DIAGRAM DEFINITION AND TIMING

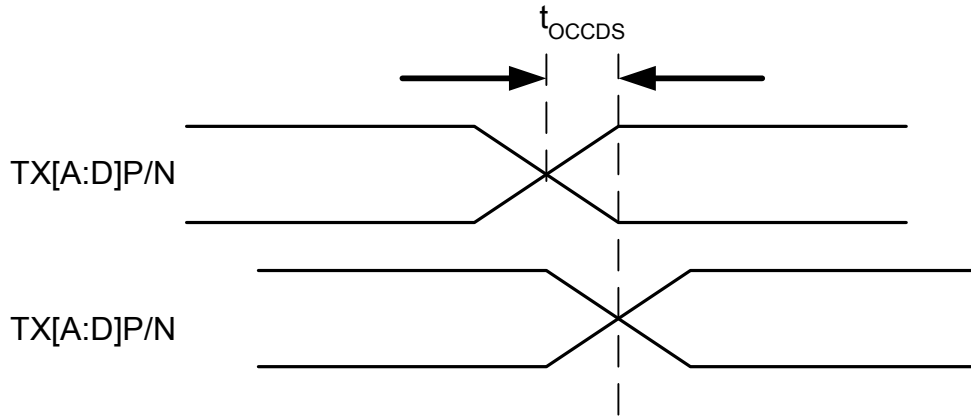

FIGURE 6-13. CHANNEL-TO-CHANNEL DIFFERENTIAL SKEW

Applications Information

DTE XGXS (XGMII-to-XAUI) Setup

One of many applications of the BBT3420 is utilizing it as a 10Gigabit Ethernet DTE XGXS device. The following discussion focuses on configuring the BBT3420 to operate as a DTE XGXS device. It also assumes the default register setting after a hard reset.

The MFC and MFD pins have internal pull-up resistors (approx. 50k Ω), therefore no external resistor is needed to configure the BBT3420 to DEVICE ADDRESS 5 (see Table 3-5). The CODE and PSYNC pins should be pulled HI (to V_{DDQ}), and BISTEN and LPENA-D pulled LOW (to GND); all these pins except PSYNC have internal pulls to these values.

Some of the default register settings need to be changed, for XGMII-to-XAUI operation. The register addresses are described with the Clause 22 address followed by the Clause 45 address. The default value of the A_ALIGN_DIS bit of the Symbol and Elasticity Control MII Register (19'h/C000'h) will cause channel alignment to occur on IDLE to non-IDLE transitions across all four channels. This can be changed to channel alignment on /A/ (K28.3) characters by setting this bit to a zero, to conform to the XAUI specification. The internal (XGMII) Error character should be set to 1FE'h by writing FE'h to 16'h/C002'h. The pseudo-random XAUI IDLE /A/K/R/ generator should be enabled by setting the AKR_EN bit in register 1D'h/C001'h. To allow complete regeneration of the Inter Packet Gap (IPG), it is desirable to set the TRANS_EN bit in register 10'h/C001'h. For the best XAUI-conforming performance, it is also advisable to set the PCS_SYNC_EN and DSKW_SM_EN bits in register 1D'h/C000'h.

All the above listed register settings can be overridden, effectively forcing the BBT3420 to the desired conditions, by setting the XAUI_EN bit in register 1D'h/C001'h.

Additional register settings may be desirable in certain environments. If the incoming XAUI signals have traveled some distance from their source (or if the source provides a

weak signal), it will usually be advisable to use the equalizer to improve the signal integrity. Similarly, if the transmitted XAUI signals are to travel a significant distance, pre-emphasis may be desirable. Both these can be changed from their default values (0'h) via register 1C'h/C005'h. It may also be found desirable to alter the LOS detector threshold, using register 1D'h/C001'h.

Recommended Analog Power and Ground Plane Splits

The BBT3420 high-speed analog circuits as well as high-speed I/O draw power from the analog power (V_DDA) and analog ground GNDA pins/balls (pins or balls will be used inter-changeably throughout this document). In order for the BBT3420 to achieve best performance, the V_DDA and GNDA shall be kept as "quiet" as possible.

The V_DDA voltage requirement of the BBT3420 is 1.8V. The ripple noise on the V_DDA voltage rail shall be as low as possible for best jitter performance. Therefore, in the layout, V_DDA shall be decoupled from the main supply of 1.8V by means of a cut out in the power plane. The 1.8V power to V_DDA is supplied through a ferrite bead (capable of 1A is recommended). The cut out spacing shall be at least 20mil.

A "quiet" analog ground also enhances the jitter performance of the BBT3420 as well. A similar cut out in the ground plane is recommended. Analog ground (GNDA) shall be tied to digital ground (GND) through a ferrite bead (capable of at least 1A is recommended).

Recommended Power Supply Decoupling

For BBT3420, the decoupling for V_DDA V_DDD and V_DDDQ must all be handled individually.

V_DDA (1.8V) provides power to the analog circuits as well as the high speed I/Os. The analog power supply V_DDA must have impedance less than 0.4 Ω from around 50kHz to 1GHz. This can be achieved by using one 22 μ F (1210 case size, CERAMIC), nine 0.1 μ F (0402 case size, ceramic), and nine 0.01 μ F (0402 case size, ceramic) capacitors in parallel. The

0.01 μ F and 0.1 μ F 0402 case size capacitors must be placed right next to the VDDA balls as close as possible. Note that the 22 μ F capacitor must be of 1210 case size, and it must be ceramic for lowest ESR possible. The 0.01 μ F must be of case size 0402, this offers the lowest ESL to achieve low impedance towards the GHz range. Also, note that the ground of these capacitors must be connected to GNDA.

VDD (1.8V) is the power rail for the core logic circuit. For the VDD, at least six 0.1 μ F (0402 case size), six 0.01 μ F (0402 case size) and a 10 μ F (tantalum) capacitor are recommended. Place the 0.01 μ F and 0.1 μ F capacitors as close to the VDD balls as possible.

V_{DDQ} (1.8V or 2.5V) is the power rail for all the low speed I/O drivers; at least ten 0.01 μ F (0402 case size), ten 0.1 μ F (0402 case size) capacitors are recommended. Place the 0.01 μ F and 0.1 μ F capacitors as close to the V_{DDQ} balls as possible.

Ordering Information

| PRODUCT | FREQUENCY | PACKAGE | ORDER PART NUMBER |
|---------|------------------|---------|-------------------|
| BBT3420 | 2.488-3.1875Gbps | BGA-289 | BBT3420-SN |

© Copyright Intersil Americas LLC 2004-2005. All Rights Reserved.
All trademarks and registered trademarks are the property of their respective owners.

For additional products, see www.intersil.com/en/products.html

Intersil products are manufactured, assembled and tested utilizing ISO9001 quality systems as noted in the quality certifications found at www.intersil.com/en/support/qualandreliability.html

Intersil products are sold by description only. Intersil may modify the circuit design and/or specifications of products at any time without notice, provided that such modification does not, in Intersil's sole judgment, affect the form, fit or function of the product. Accordingly, the reader is cautioned to verify that datasheets are current before placing orders. Information furnished by Intersil is believed to be accurate and reliable. However, no responsibility is assumed by Intersil or its subsidiaries for its use; nor for any infringements of patents or other rights of third parties which may result from its use. No license is granted by implication or otherwise under any patent or patent rights of Intersil or its subsidiaries.

For information regarding Intersil Corporation and its products, see www.intersil.com