

VAL-US-240/40-P - Type 1 surge protection plug



2910336

<https://www.phoenixcontact.com/us/products/2910336>

Please be informed that the data shown in this PDF document is generated from our online catalog. Please find the complete data in the user documentation. Our general terms of use for downloads are valid.



UL Recognized type 1 SPD and IEC type 2 surge protection plug with a varistor and thermal disconnect for use with VAL-US base elements, mechanical and visual fault warning

Product description

Surge protective device replacement plug

Commercial data

Item number	2910336
Packing unit	1 pc
Sales key	CL18
Product key	CL1321
Catalog page	Page 93 (C-4-2019)
GTIN	4055626444482
Weight per piece (including packing)	52.5 g
Weight per piece (excluding packing)	46 g
Customs tariff number	85363030
Country of origin	DE

VAL-US-240/40-P - Type 1 surge protection plug

2910336

<https://www.phoenixcontact.com/us/products/2910336>

Technical data

Notes

General	Used in:
---------	----------

Product properties

IEC test classification	II
	T2
EN type	T2
Type	Male
Product type	Replacement plug
Product family	VALVETRAB MS
Number of positions	1
Surge protection fault message	optical

Insulation characteristics

Overvoltage category	III
Pollution degree	2

Electrical properties

Nominal frequency f_N	50 Hz (60 Hz)
-------------------------	---------------

Connection data

Connection method	VALVETRAB plug-in system
-------------------	--------------------------

Dimensions

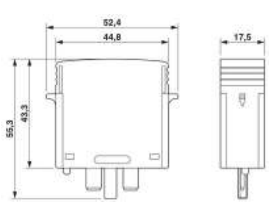
Dimensional drawing	
Width	17.5 mm
Height	52.4 mm
Depth	55.3 mm
Horizontal pitch	1 Div.

Material specifications

Flammability rating according to UL 94	V-0
CTI value of material	600
Insulating material	PA 6.6/PBT
Material group	I
Housing material	PA 6.6
	PBT

VAL-US-240/40-P - Type 1 surge protection plug



2910336

<https://www.phoenixcontact.com/us/products/2910336>

Protective circuit

Mode of protection	L-N
	L-PEN
	N-PE
Direction of action	1L-N/PE
Nominal voltage U_N	240/415 V AC
Nominal frequency f_N	50 Hz (60 Hz)
Maximum continuous voltage U_C	385 V AC
Residual current I_{PE}	$\leq 450 \mu\text{A}$
Standby power consumption P_C	$\leq 175 \text{ mVA}$
Nominal discharge current I_n (8/20) μs	20 kA
Maximum discharge current I_{max} (8/20) μs	40 kA
Short-circuit current rating I_{SCCR}	25 kA
Voltage protection level U_p	$\leq 1.8 \text{ kV}$
Residual voltage U_{res}	$\leq 1.8 \text{ kV}$ (at I_n)
	$\leq 1.6 \text{ kV}$ (at 10 kA)
	$\leq 1.4 \text{ kV}$ (at 5 kA)
	$\leq 1.3 \text{ kV}$ (at 3 kA)
TOV behavior at U_T	415 V AC (5 s / withstand mode)
	440 V AC (120 min / withstand mode)
Max. backup fuse with branch wiring	100 A (gG)

Additional technical data

Maximum discharge current I_{max} (8/20) μs	40 kA
--	-------

Environmental and real-life conditions

Ambient conditions

Degree of protection	IP20
Ambient temperature (operation)	-40 °C ... 80 °C
Ambient temperature (storage/transport)	-40 °C ... 80 °C
Altitude	$\leq 2000 \text{ m}$ (amsl)
Permissible humidity (operation)	5 % ... 95 %
Shock (operation)	25g (Half-sine / 11 ms / 3x $\pm X$, $\pm Y$, $\pm Z$)
Vibration (operation)	5g (10 ... 500 Hz / 2.5 h / X, Y, Z)

Approvals

UL specifications

Maximum continuous operating voltage MCOV	385 V AC
Short-circuit current rating (SCCR)	200 kA
Voltage protection rating VPR	1200 V
UL type	type 1
Nominal discharge current I_n	20 kA
Maximum Surge Current per Phase	40 kA

VAL-US-240/40-P - Type 1 surge protection plug



2910336

<https://www.phoenixcontact.com/us/products/2910336>

Mode of protection	L-N
	L-G
	N-G
Nominal voltage	240/480 V AC
Power distribution system	Single phase
Nominal frequency	50/60 Hz
SPD Type	1CA

Standards and regulations

Air clearances and creepage distances

Standards/regulations	EN 60664-1 / EN 61643-11
Standards/specifications	IEC 61643-11
Note	2011
Standards/specifications	EN 61643-11
Note	2012

Mounting

Mounting type	on base element
---------------	-----------------

VAL-US-240/40-P - Type 1 surge protection plug

2910336

<https://www.phoenixcontact.com/us/products/2910336>



Drawings

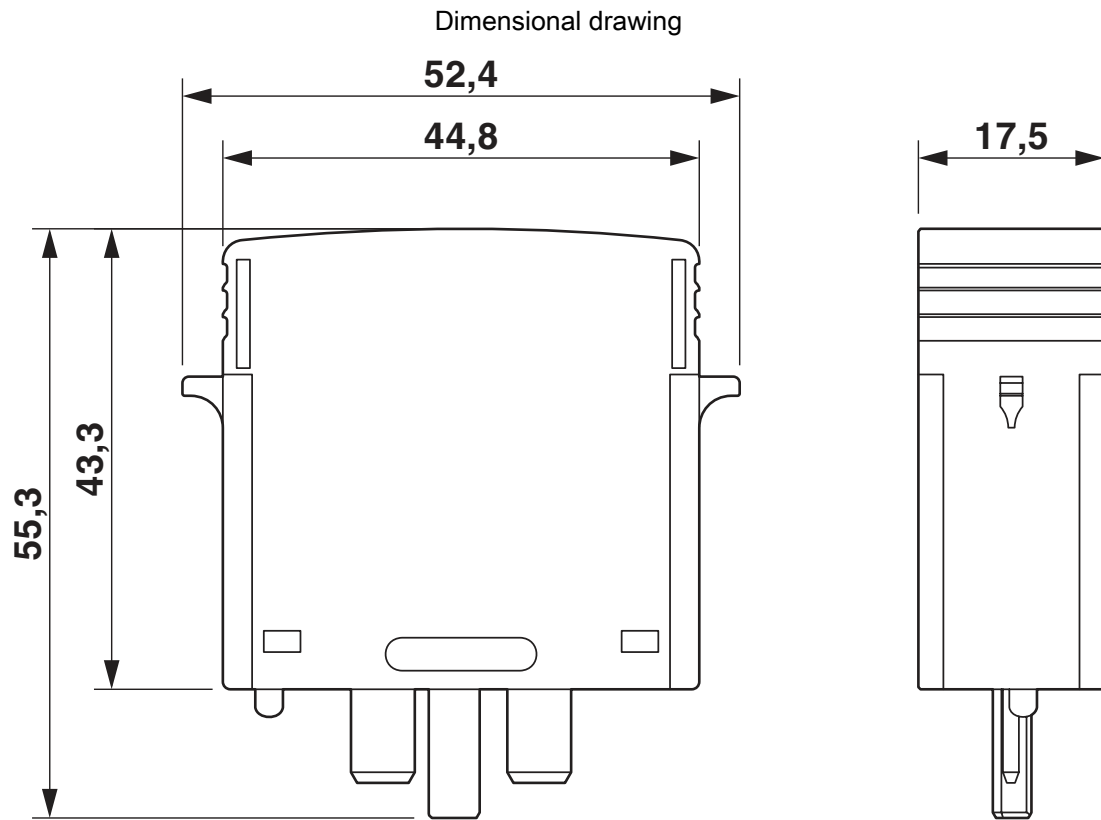

Circuit diagram



VAL-US-240/40-P - Type 1 surge protection plug



2910336

<https://www.phoenixcontact.com/us/products/2910336>

Approvals

To download certificates, visit the product detail page: <https://www.phoenixcontact.com/us/products/2910336>



cUL Recognized

Approval ID: FILE E 330181



UL Recognized

Approval ID: FILE E 330181

cULus Recognized

VAL-US-240/40-P - Type 1 surge protection plug



2910336

<https://www.phoenixcontact.com/us/products/2910336>

Classifications

ECLASS

ECLASS-11.0	27130890
ECLASS-13.0	27171292

ETIM

ETIM 8.0	EC002496
----------	----------

UNSPSC

UNSPSC 21.0	39121600
-------------	----------

VAL-US-240/40-P - Type 1 surge protection plug



2910336

<https://www.phoenixcontact.com/us/products/2910336>

Environmental product compliance

China RoHS	Environmentally friendly use period: unlimited = EFUP-e
	No hazardous substances above threshold values

VAL-US-240/40-P - Type 1 surge protection plug

2910336

<https://www.phoenixcontact.com/us/products/2910336>



Accessories

VAL-US-240/40/1+0-FM - Type 1 surge protection device

2910361

<https://www.phoenixcontact.com/us/products/2910361>



Surge protective device, single channel with remote indicator contact for 240 V AC.

VAL-US-240/40/1+1-FM - Type 1 surge protection device

2910362

<https://www.phoenixcontact.com/us/products/2910362>



Surge protective device, two channel with remote indicator contact for 240 V AC, 2-wire plus ground.

VAL-US-240/40-P - Type 1 surge protection plug

2910336

<https://www.phoenixcontact.com/us/products/2910336>

VAL-US-240/40/2+0-FM - Type 1 surge protection device

2910364

<https://www.phoenixcontact.com/us/products/2910364>



Surge protective device, two channel with remote indicator contact for 240/480 V split phase AC, 3-wire.

VAL-US-240/40/2+1-FM - Type 1 surge protection device

2910365

<https://www.phoenixcontact.com/us/products/2910365>



Surge protective device, three channel with remote indicator contact for 240/480 V split phase AC, 3-wire plus ground.

VAL-US-240/40-P - Type 1 surge protection plug

2910336

<https://www.phoenixcontact.com/us/products/2910336>

VAL-US-240/40/3+0-FM - Type 1 surge protection device

2910366

<https://www.phoenixcontact.com/us/products/2910366>



Surge protective device, three-channel with remote indicator contact for 240/480 V split-phase or 240/415 V Wye three-phase AC, 4-wire.

VAL-US-240/40/3+1-FM - Type 1 surge protection device

2910367

<https://www.phoenixcontact.com/us/products/2910367>



Surge protective device, four channel with remote indicator contact for 240/415 V AC, 4-wire plus ground.

VAL-US-240/40-P - Type 1 surge protection plug

2910336

<https://www.phoenixcontact.com/us/products/2910336>



VAL-US-480HLD/30/3+1V-FM - Type 1 surge protection device

2910387

<https://www.phoenixcontact.com/us/products/2910387>



Surge protective device, four channel with remote indicator contact for 480 V AC high-leg DELTA.

Phoenix Contact 2023 © - all rights reserved

<https://www.phoenixcontact.com>

Phoenix Contact USA
586 Fulling Mill Road
Middletown, PA 17057, United States
(+717) 944-1300
info@phoenixcon.com