

INTF3000 Interface Board

Evaluates: EV Kits Requiring SPI/ Parallel to USB Interface

General Description

The INTF3000 interface board is designed to facilitate the interfacing of Maxim's evaluation kit (EV) boards to any personal computer (PC) through the USB port.

There are three different connectors on the INTF3000 interface board available to communicate with the EV board: INTF2300, INTF2400, and DB25 (LPT) parallel connector. The INTF2400 connector is intended for new designs, while the INTF2300, INTF2400, and DB25 parallel connector can support legacy EV boards that are already configured for one of these types of interfaces. It must be noted that legacy EV boards that were designed to communicate with the PC through DB25 parallel port must also have an updated control software which supports the INTF3000 interface board.

All three connectors on INTF3000 interface board support logic levels from 2V to 5V. The INTF3000 requires no special driver installations on the host PC. The board connects to the PC with a standard USB cable.

Benefits and Features

- Parallel Port-to-USB Interface
- Serial port interface (SPI) to USB Interface
- Supports Wide Voltage Range: 2V – 5V
- INTF2400 Connector Compatible with Old INTF2400 LPT Port Boards
- Addressing Enables the Use of up to Four Boards on a Single PC

Ordering Information appears at end of data sheet.

Quick Start

Required Equipment

This section lists the recommended equipment to verify the operation of INTF3000.

- 1) INTF3000 interface board
- 2) PC equipped with Microsoft Windows XP®, Windows® 7, Windows® 8 OS and a USB port
- 3) USB-A male to USB-B male cable
- 4) Optional: ribbon cable
- 5) Optional: DC supply capable of delivering 2.0V to 5.0V and 10mA current

Procedure

The interface board is fully assembled and tested. Follow the steps below to verify board operation:

- 1) Connect the INTF3000 to the PC using a USB-A cable to USB-B male cable.
- 2) Connect to the EV board to the INTF3000 using either DB25 parallel port connector directly or through ribbon cable connected between INTF2400/INTF2300 connector. This depends on what type of connector is present on the EV kit.
- 3) Connect JU1 in V_{BUS} position to drive everything from 5V from USB.
- 4) Alternatively, connect JU1 in V_{DEV} position to bias the drivers from EV board V_{DEV} pin, if V_{CC} is routed to V_{DEV} .
- 5) If JU1 is removed, an external supply (V_{CC}) must be connected to the test point: V_{PULL} .

Detailed Description of Hardware

This section describes the hardware of the INTF3000 board, explains how the jumpers and connectors should be used by highlighting the input and output signals, and where they are routed to on each of the three connectors. [Figure 1](#) shows the location of these jumpers and connectors.

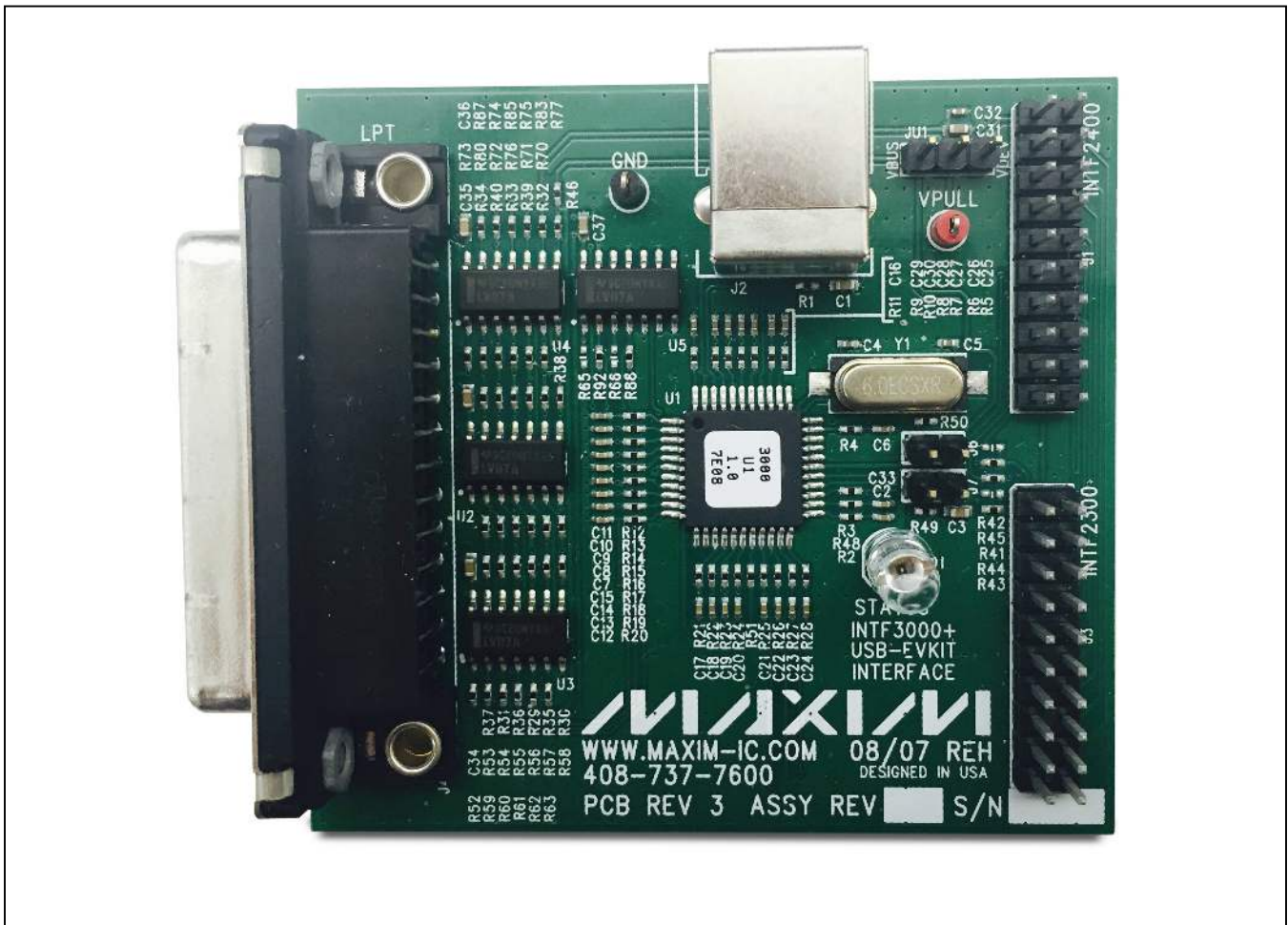

Figure 1. INTF3000 Board

Input Port Signals

There is one port (port D) on the USB controller (U1) dedicated to inputs. There are seven possible input port pins on this port and each interface connector has a different number of these pins available. [Table 1](#), [Table 2](#), and [Table 3](#) show the available input pins on each connector.

The inputs are read by the USB controller, with the state returned to the PC. These input signals can be used to determine the state of pins on the DUT or EV board. The logic level of the input buffers is determined by V_{PULL} ; it should always be set to the V_{CC} of the EV board.

Table 1. Input Pins on INTF2400

INTF2400 PIN	U1 INPUT PORT PIN
9	RD3L
11	RD2L
13	RD1L
15	RD0L

Table 2. Input Pins on INTF2300

INTF2300 PIN	U1 INPUT PORT PIN
1*	RD4L
2	RD6L
3*	RD5L
4	RD7L

**Must be enabled with jumper on the INTF3000 board, otherwise, these pins are ground.*

Table 3. Input Pins on LPT Connector

LPT PIN	U1 INPUT PORT PIN
10	RD0L
11	RD1L
12	RD2L
13	RD3L
15	RD4L

Output Port Signals

The USB controller (U1) has two output ports (RA and RB) connected to the interface connectors. There are a maximum of twelve output port signals available on the INTF3000 board. Each of the three connectors has a different number of these signals available. [Table 4](#), [Table 5](#), and [Table 6](#) show the available output signals on each connector.

The output buffers (U2–U5) can either drive each output pin low or let it float. A pullup resistor on each line pulls the output to V_{PULL} , setting it to high level when floating. V_{PULL} can be supplied by different sources depending on jumper JU1 setting and this allows for DUT logic levels from 2V to 5V.

Table 4. Output Pins for INTF2400

INTF2400 PIN	U1 OUTPUT PORT PIN
2	RB0L
4	RB1L
6	RB2L
8	RB3L
10	RB4L
12	RB5L
14	RB6L
16	RB7L
17	RA2L
18	RA0L
19	RA3L
20	RA1L

Table 5. Output Pins for INTF2300

INTF2300 PIN	U1 OUTPUT PORT PIN
6	RB6L
8	RB5L
10	RB4L
14	RB3L
16	RB2L
18	RB1L
20	RB0L

The outputs can be a serial clock, serial data, serial chip select, or just a control pin to turn on/off functions on the DUT. Serial signals are not limited to a specific pin; the software, not the hardware, defines the function of each output pin.

Jumpers

JU1

JU1 configures the pullup resistors for the output drivers (U2 and U3). Each output RA0–RA5 and RB0–RB7 has an open-drain driver. These drivers are used to level translate the 5V logic of the USB controller to the lower voltage logic levels of the DUT EV board.

If JU1 is in the V_{BUS} position, the inputs and outputs of the drivers are compatible with 5V logic only.

If JU1 is in the V_{DEV} position, the drivers get their bias from the logic supply voltage of the DUT EV board through Pin 1 of INTF2400 or Pin 12 of INTF2300 connector. It should be noted that the DUT EV board must have the logic supply voltage routed to these pins.

If JU1 is removed, an external V_{CC} can be connected to the test point (V_{PULL}). This configuration must be used for low V_{CC} boards that do not have their V_{CC} routed to V_{DEV}. Some legacy EV boards that have the DB25 connector must use this configuration since the DB25 connector does not have a V_{DEV} pin.

Table 6. Output Pins for LPT Connector

LPT PIN	U1 OUTPUT PORT PIN
1	RB0L
2	RB1L
3	RB2L
4	RB3L
5	RB4L
6	RB5L
7	RB6L
8	RB7L
9	RA0L
14	RA1L
16	RA2L
17	RA3L

JU6, JU7

JU6 and JU7 set the address of the INTF3000 board. There are four possible addresses so that up to four different INTF3000 boards may be used on one PC. Table 7 shows these four addresses and the associated jumper positions. The software used must be set to the same address as the jumper configuration.

Table 7. INTF3000 Possible Addresses

ADDRESS	JU6	JU7
9123*	Removed	Removed
9124	Removed	Installed
9125	Installed	Removed
9126	Installed	Installed

* This is the default address for most EV boards.

LED

LED D1 serves two purposes:

- 1) D1 will blink once when the INTF3000 is first connected. This shows that the processor has powered-up properly.
- 2) D1 will toggle on and off for every command received from the PC. This shows activity.

INTF3000 Interface Board

Evaluates: EV Kits Requiring SPI/Parallel to USB Interface

Interface Connectors

Parallel (LPT) Connector

The parallel port connector is a DB25 connector wired to have the same pinout as a parallel port. This connector can be used to connect to legacy EV boards, which use the DB25 connector as shown in Figure 3. Table 8 shows the port pins associated with this connector.

For legacy boards, if the DUT $V_{CC} < 3.3V$, remove JU1 and connect test point V_{PULL} to the same voltage as the EV board V_{CC} ; if the DUT $V_{CC} \geq 3.3V$, put JU1 in the V_{BUS} position and no connection to V_{PULL} is necessary.

Table 8. LPT Connector Port Pins

DB25 PIN	LABEL	FUNCTION
1	RB0L	Output Pin
2	RB1L	Output Pin
3	RB2L	Output Pin
4	RB3L	Output Pin
5	RB4L	Output Pin
6	RB5L	Output Pin
7	RB6L	Output Pin
8	RB7L	Output Pin
9	RA0L	Output Pin
10	RD0L	Input Pin
11	RD1L	Input Pin
12	RD2L	Input Pin
13	RD3L	Input Pin

DB25 PIN	LABEL	FUNCTION
14	RA1L	Output Pin
15	RD4L	Input Pin
16	RA2L	Output Pin
17	RA3L	Output Pin
18	GND	Power Pin
19	GND	Power Pin
20	GND	Power Pin
21	GND	Power Pin
22	GND	Power Pin
23	GND	Power Pin
24	GND	Power Pin
25	GND	Power Pin

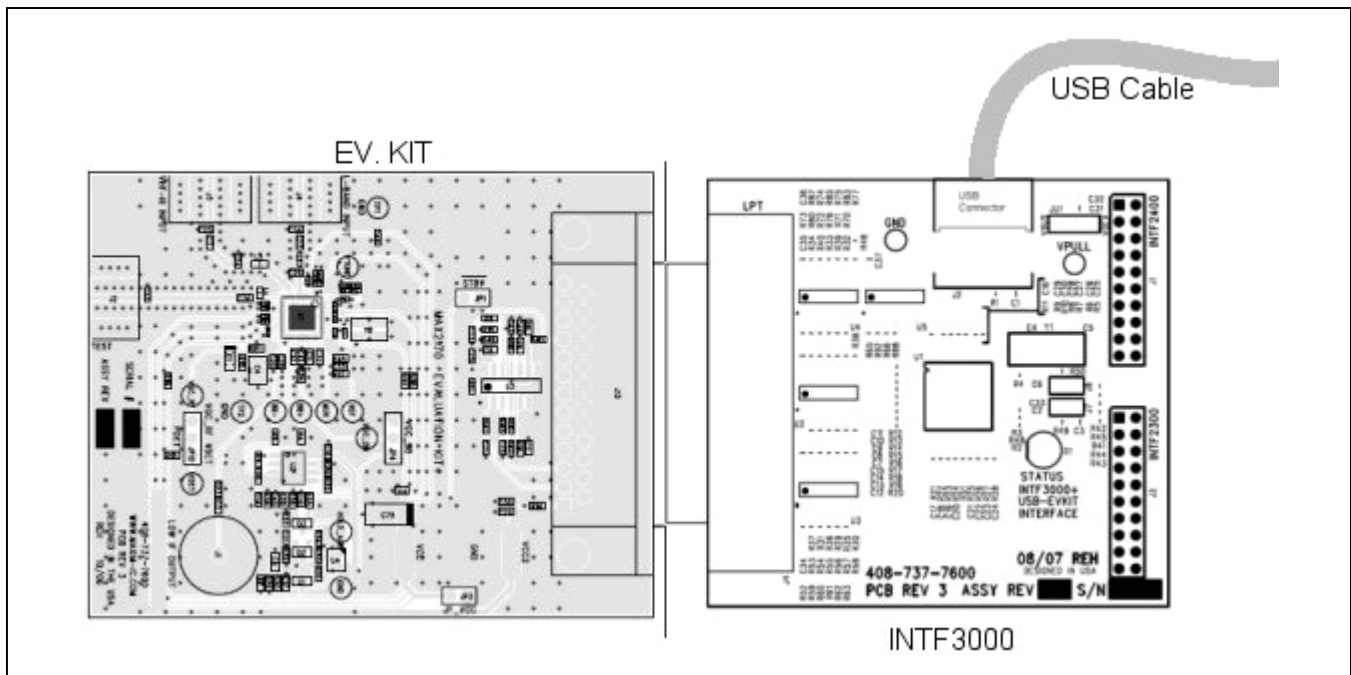

Figure 2. Sample Connection to Legacy EV boards with DB25 Connector

INTF3000 Interface Board

Evaluates: EV Kits Requiring SPI/Parallel to USB Interface

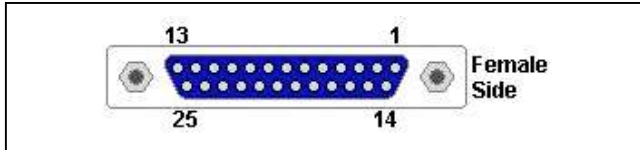

Figure 3. Parallel Connector (DB25)

INTF2300 Connector

The INTF2300 connector is wired to be compatible with the old INTF2300 LPT port interface board. [Figure 4](#) shows the connector pin out.

Pins RB0L–RB6L are outputs and may be connected to serial bus pins (SDA, SCLK, CS) or may be used to control any logic function such as enabling amplifiers, routing signals, SHDN, etc. Pins RD6L and RD7L are inputs and can be connected to SDA (I²C), SDAO (SPI), Lock Detect readback, or any other logic level that needs to be read back.

VDEV is routed to V_{CC} of DUT and it is connected to V_{PULL} through JU1 setting so that the drivers are properly pulled high to V_{CC} of the EV board. GND is used to connect to EV board GND.

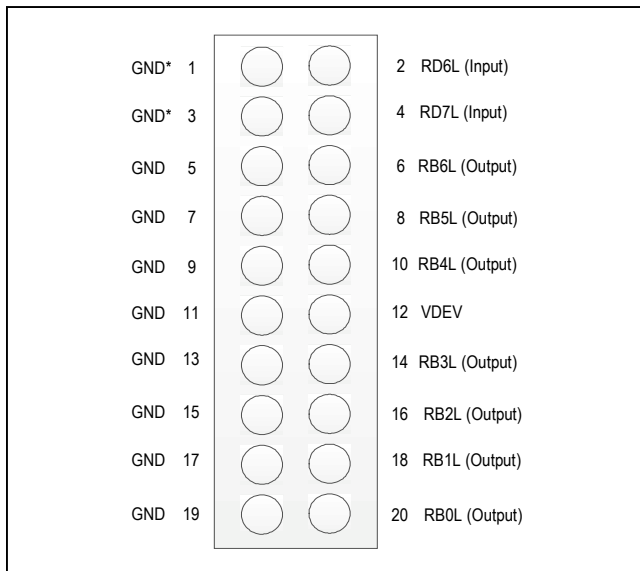

Figure 4. INTF2300 Connector Pinout

*Pins 1 and 3 may optionally be configured as inputs by populating/unpopulating resistors R42, R43, R44, and R45. [Table 9](#) shows the configuration of these resistors and the corresponding pin behavior.

INTF2400 Connector

The INTF2400 connector is wired to be compatible with the old INTF2400 LPT port interface board. It will work with legacy boards as long as the software is updated. The INTF2400 connector is also intended as the primary interface for newer designs since it has more I/O pins than the INTF2300. [Figure 4](#) shows the connector pinout.

Pins RB0L–RB7L and RA0L–RA3L are outputs and may be connected to serial bus pins (SDA, SCLK, CS) or may be used to control any logic function, such as enabling amplifiers, routing signals, SHDN, etc.

Pins RD0L–RD3L are inputs and can be connected to SDA (I²C), SDAO (SPI), Lock Detect readback, or any other logic level that needs to be read back.

VDEV is routed to V_{CC} of DUT and it is connected to V_{PULL} through JU1 setting so that the drivers are properly pulled high to V_{CC} of the EV board. GND is used to connect to EV board GND.

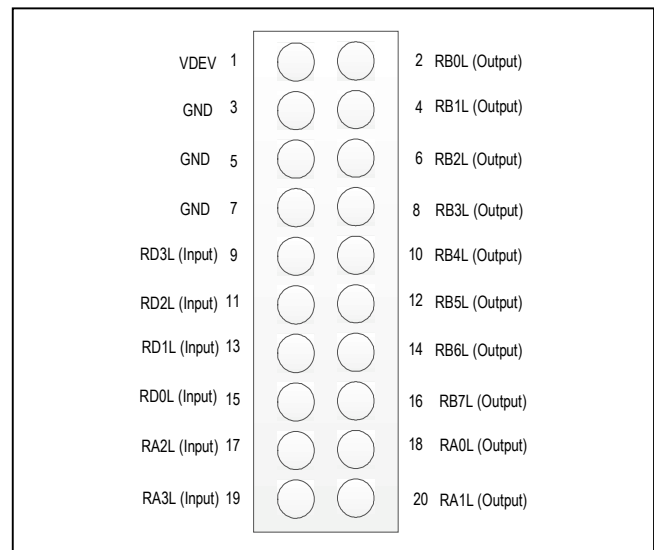

Figure 5. INTF2400 Connector Pinout

Table 9. Pin 1 and 3 Configurations

RESISTOR	PINS 1, 3 = GND	PINS 1, 3 = INPUTS
R42	Removed	0Ω
R43	0Ω	Removed
R44	Removed	0Ω
R45	0Ω	Removed

Two-Wire Serial Communication

2-wire serial data communication actually requires three wires; one for SDA in to the DUT, one for SDA out from the DUT, and one wire for SCLK. The SDA wire from the DUT to any RD input of USB controller is required and not optional. Any RB or RA output pin may be used for serial clock and serial data out.

Figure 6 shows an example of how the 2-wire serial communication can be set up using INTF2400 connector. The INTF2300 may also be used but the pinout is different and the number of available pins is less than the INTF2400. Pins RD0L–RD3L are inputs to the INTF2400 and they may be used for Lock Detect readback or any other output from the EV board or device. Pins RB0–RB7, RA0–RA3 are outputs and may control any logic function on the EV board (i.e., SHDN, STBY, Switches, Power Amps, etc.).

VDEV must be used for DUTs with a VCC lower than 5V. The DUT's VCC should be fed back to INTF3000 board so that its output buffers translate the logic levels correctly. In this case, jumper JU1 should be put to the VDEV position.

3-Wire Serial Communication

3-wire serial communication requires SCLK, SDA, and CS. These signals can be connected to any of the output pins: RB0–RB7, RA0–RA3.

Figure 7 shows an example how 3-wire serial communication can be set up with the INTF2400 connector to control one chip/ EV board. The INTF2300 may also be used but the pinout is different and the number of available pins is less than the INTF2400.

Figure 8 shows another example how 3-wire serial communication can be set up with an INTF2400 connector to control more than one chip/ EV board.

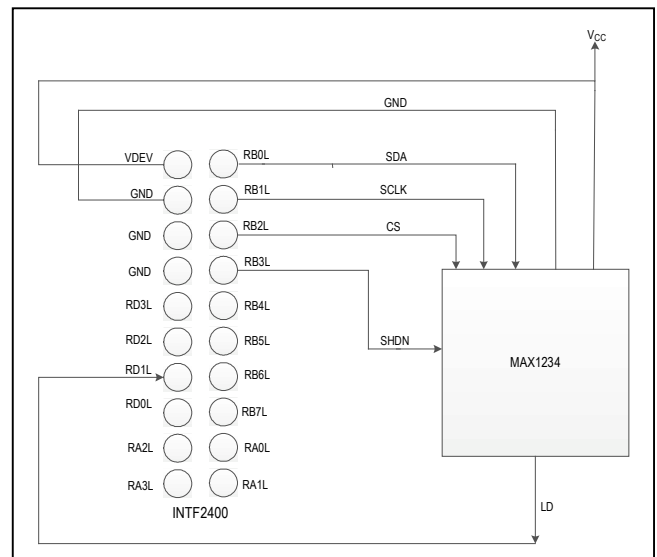

Figure 7. 3-Wire Serial Communication with One Chip

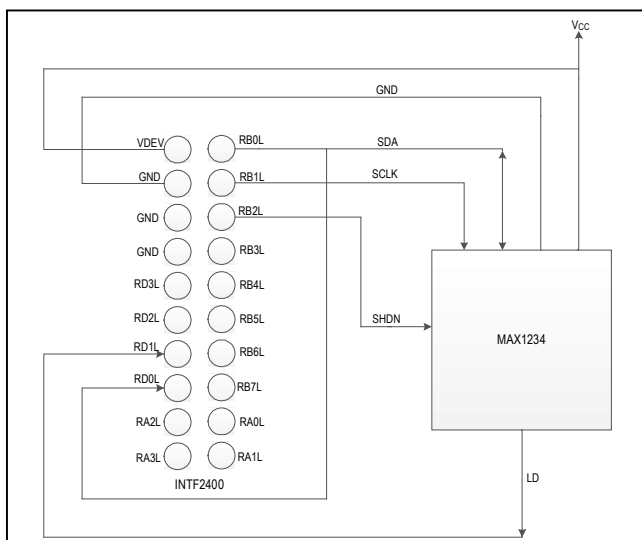

Figure 6. 2-Wire Serial Communication Example Schematic

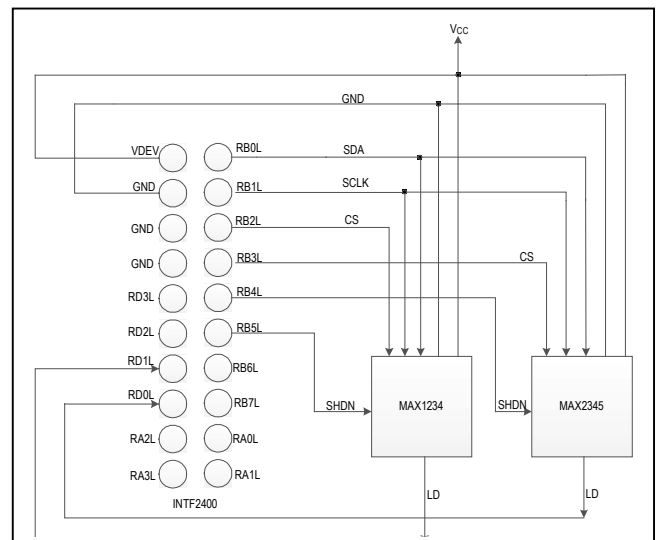

Figure 8. 3-Wire Serial Communication with Multiple Chips

Mixed 2 and 3-Wire Serial Communication

2 and 3-wire serial communication can be used at the same time to control multiple DUTs with SPI or I2C buses. The same rules will be followed as those for individual buses.

4-Wire Serial Communication

4-wire serial communication requires SCLK, SDAO, SDAI and CS. Signals SCLK, SDAI, CS are outputs from the INTF3000 and should be connected to one of the output port pins: RB0–RB7, RA0–RA3. The configuration shown in [Figure 10](#) is the preferred pinout.

Pins RD0L–RD3L are inputs to the INTF3000, so one of these should be used for SDAO (data output from DUT, input to the INTF3000). The other input pins may be used for any other signal from the EV board such as Lock Detect.

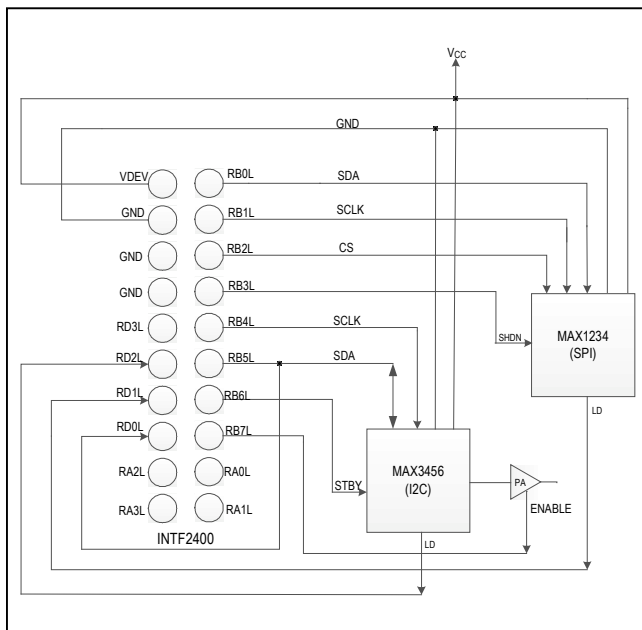

Figure 9. Mixed 2 and 3-Wire Serial Communication Example Schematic

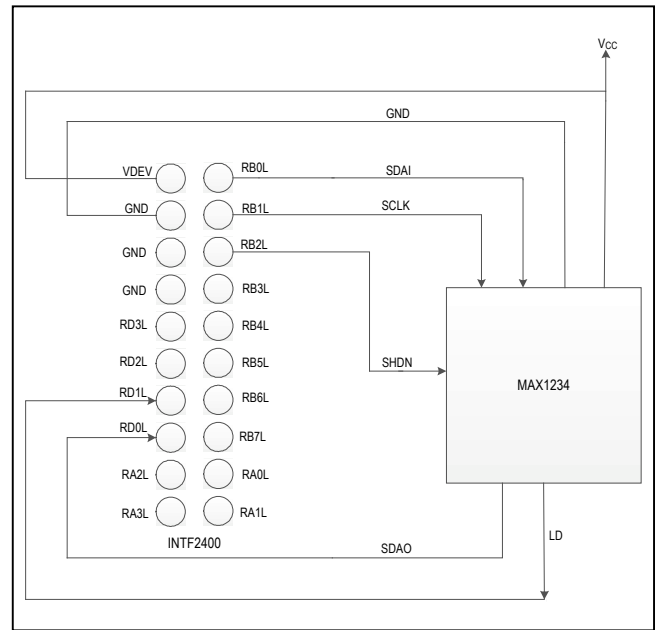

Figure 10. 4-Wire Serial Communication Example Schematic

Component Suppliers

SUPPLIER	WEBSITE
Murata Americas	www.murata.com
Fairchild	www.fairchildsemi.com
Microchip Technology	www.microchip.com
Texas Instrument	www.ti.com
ECS, Inc.	www.ecsxtal.com
Sullins Corp	www.sullinscorp.com
ASSMANN Electronics	www.assmann.com
Keystone Electronics	www.keyelco.com

Component Information, PCB Files, and Schematic

See the following links for component information, PCB files, and schematic.

- [INTF3000 EV BOM](#)
- [INTF3000 EV PCB Files](#)
- [INTF3000 EV Schematic](#)

Note: All design files provided are intended to be used as reference only.

Ordering Information

PART	TYPE
INTF3000+	EVKIT

Revision History

REVISION NUMBER	REVISION DATE	DESCRIPTION	PAGES CHANGED
0	11/15	Initial release	—

For pricing, delivery, and ordering information, please contact Maxim Direct at 1-888-629-4642, or visit Maxim Integrated's website at www.maximintegrated.com.

Maxim Integrated cannot assume responsibility for use of any circuitry other than circuitry entirely embodied in a Maxim Integrated product. No circuit patent licenses are implied. Maxim Integrated reserves the right to change the circuitry and specifications without notice at any time.

PART	QTY	DESCRIPTION
C1, C3, C31, C34, C35, C36, C37	7	0.1uF 10% 0603 Capacitor Murata GRM188R71C104K
C2, C6, C7, C8, C9, C10, C11, C12, C13, C14, C15, C16, C17, C18, C19, C20, C21, C22, C23, C24, C25, C26, C27, C28, C29, C30, C33	27	330pF 10% 0402 Capacitor Murata GRM155R71H331K
C4, C5	2	330pF 10% 0402 Capacitor Murata GRM155R71H331K
C32	1	10nF 10% Capacitor Murata GRM155R71E103K
R1	1	1.5K 5% 0402 Resistor
R2, R3, R4, R5, R6, R7, R8, R9, R10, R11, R12, R13, R14, R15, R16, R17, R18, R19, R20, R21, R22, R23, R24, R25, R26, R27, R28, R48, R51	29	100 ohms 5% 0402 Resistor
R29, R30, R31, R38, R39, R40, R54, R56, R58, R59, R61, R63	12	3.3K 5% 0402 Resistor
R32, R33, R34, R35, R36, R37, R49, R50, R52, R53, R55, R57, R60, R62, R70, R74, R75, R76, R77, R80, R88, R92	22	5.1K 5% 0402 Resistor
R41, R43, R45, R46	4	0 0402 Resistor
R42, R43, R44, R45, R65, R66	0	Open 0402 Resistor
R71, R72, R73, R83, R85, R87	6	51K 5% 0402 Resistor
D1	1	LIGHT EMITTING DIODE Fairchild MV8741
U1	1	PIC MICROCONTROLLER MICROCHIP TECHNOLOGY PIC16C765-I/PT
U2, U3, U4, U5	4	Hex Buffer/Driver OC Texas Instruments SN74LV07AD
Y1	1	6MHz Crystal ECS, Inc. ECS-60-20-5PX-TR
J1, J3	2	2X10 Header 2.54MM, Comes in 36-40 X 2 Pin Strips (CUT TO FIT) Sullins PEC36DAAN
J4	1	DB25 F PCB CONN HD- 20 SERIES AMP 5745783-4
J6, J7	2	1X2 Header 2-Pin Header 0.1" Centers - Cut to fit Sullins PEC36SAAN
JU1	1	1X3 Header 36-Pin Header 0.01" Centers - Cut to fit Sullins PEC36SAAN
J2	1	USB Connector - B Type ASSMANN Electronics AU-Y1007-R
GND	1	Testpoint - PC Mini-Black Keystone 5001
VPULL	1	Testpoint - PC Mini-Red Keystone 5000

ALL UNITS ARE IN 0.001"	
INTF3000 USB-EVKIT INTERFACE	REV 3
PROPERTY OF  INTEGRATED PRODUCTS STRATEGIC WIRELESS APPLICATIONS	
LAYER DRILL & MECHANICALS	SHEET 6 OF 6
DATE: 08/10/07	PCB LAYOUT:

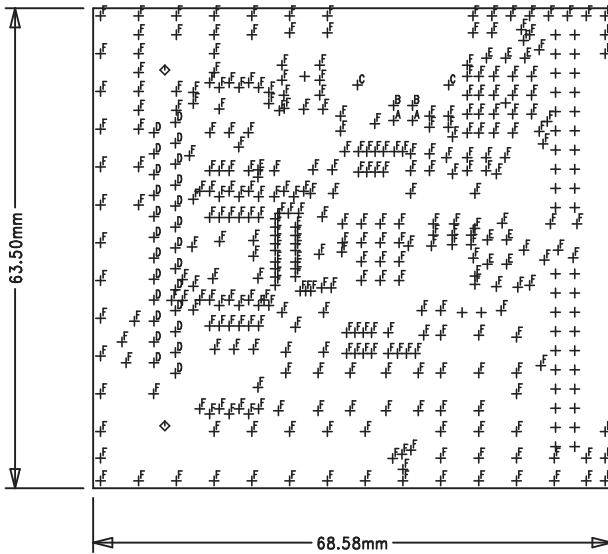

SIZE	QTY	SYM	PLATED	TOL
0.9398	44	+	YES	+/-0.0
3.175	2	◇	YES	+/-0.0
1.02	2	⊥ ^A	YES	+/-0.0
1.174	2	⊥ ^B	YES	+/-0.0
2.554	2	⊥ ^C	YES	+/-0.0
0.94	25	⊥ ^D	YES	+/-0.0
0.889	7	⊥ ^E	YES	+/-0.0
0.25	344	⊥ ^F	YES	+/-0.0

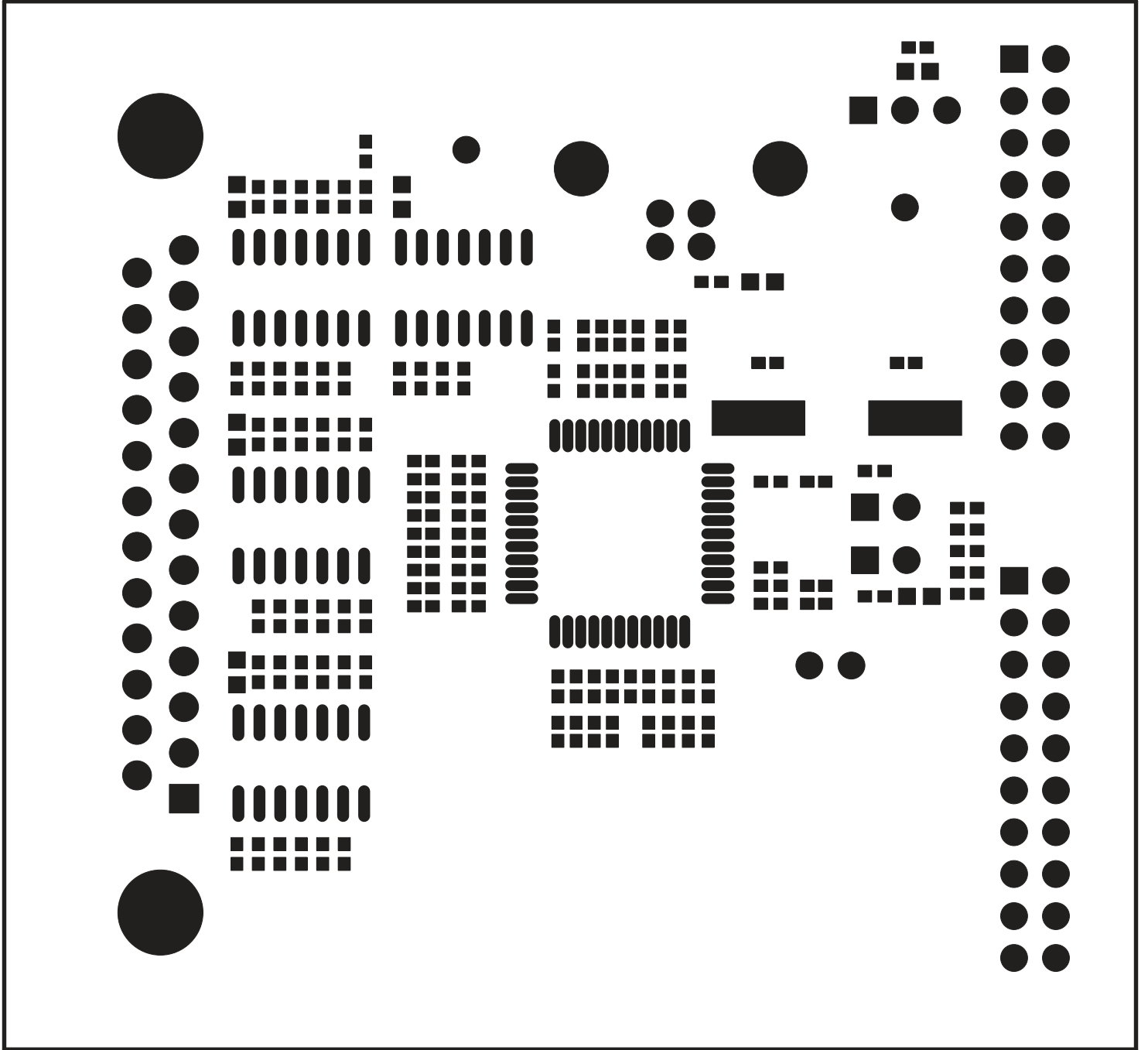

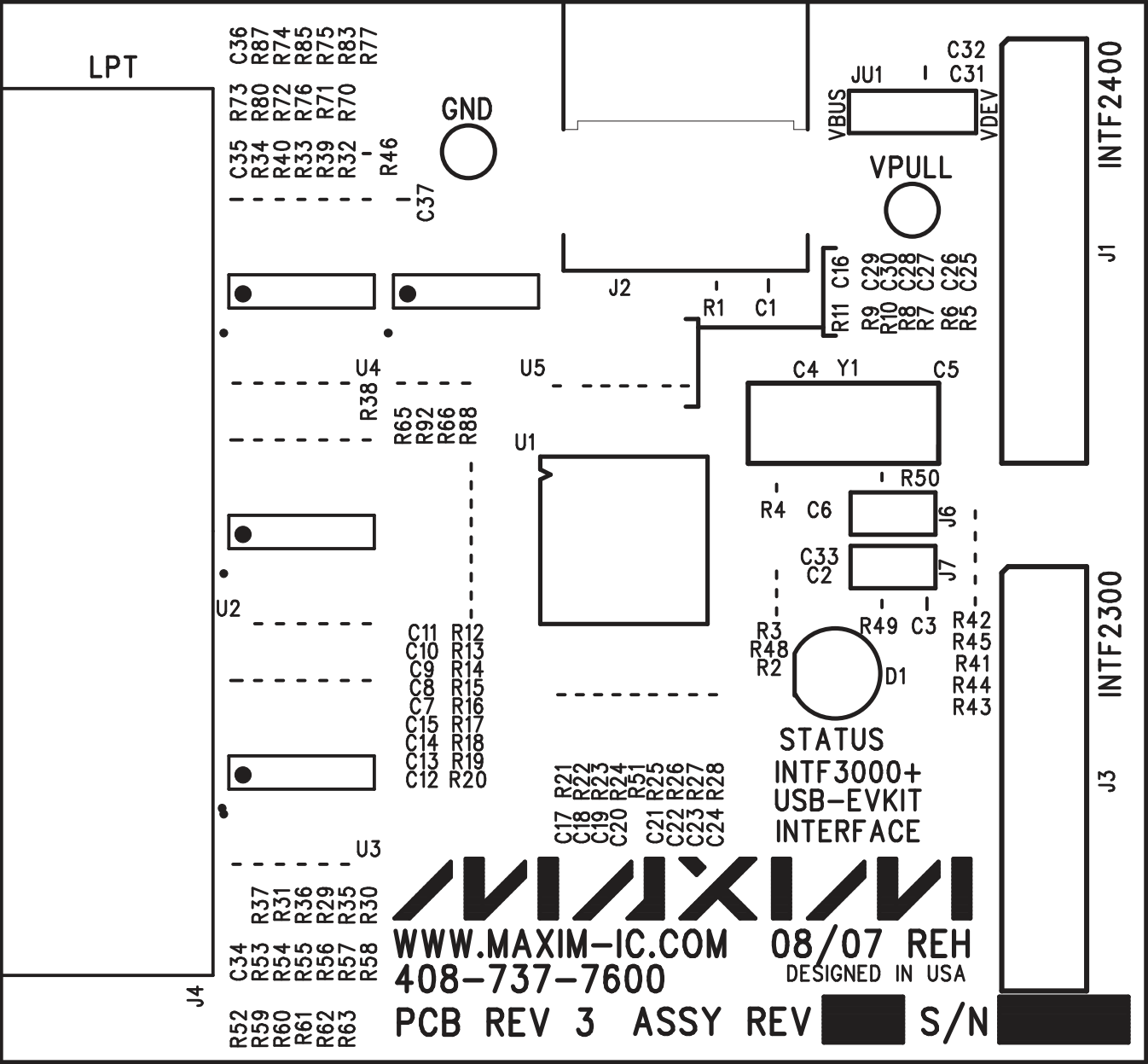

- C36 R87 R74 R85 R83 R77
- R73 R80 R72 R76 R71 R70 R75
- C35 R34 R40 R33 R39 R32 R46
- R35 R41 R34 R33 R39 R32 R46
- R65 R92 R66 R88
- C11 C10 C9 C8 C7 C6 C5 C4 C3 C2 C1
- R17 R18 R19 R20 R21 R22 R23 R24 R25 R26 R27 R28
- R52 R53 R54 R55 R56 R57 R58 R30
- R37 R31 R36 R29 R35 R30
- C34 R53 R54 R55 R56 R57 R58 R30
- R59 R60 R61 R62 R63
- C37 R46
- C38 R38
- C39 C30 C28 C27 C26 C25
- R11 R9 R10 R8 R7 R6 R5
- C4 Y1 C5
- R4 C6 R50
- C33 C2
- R3 R48 R2
- R49 C3
- R42 R45 R41 R44 R43

INTF2400

J1

INTF2300

J3

LPT

GND

VPULL

STATUS
INTF 3000+
USB-EVKIT
INTERFACE



WWW.MAXIM-IC.COM
408-737-7600

08/07 REH
DESIGNED IN USA

PCB REV 3 ASSY REV S/N

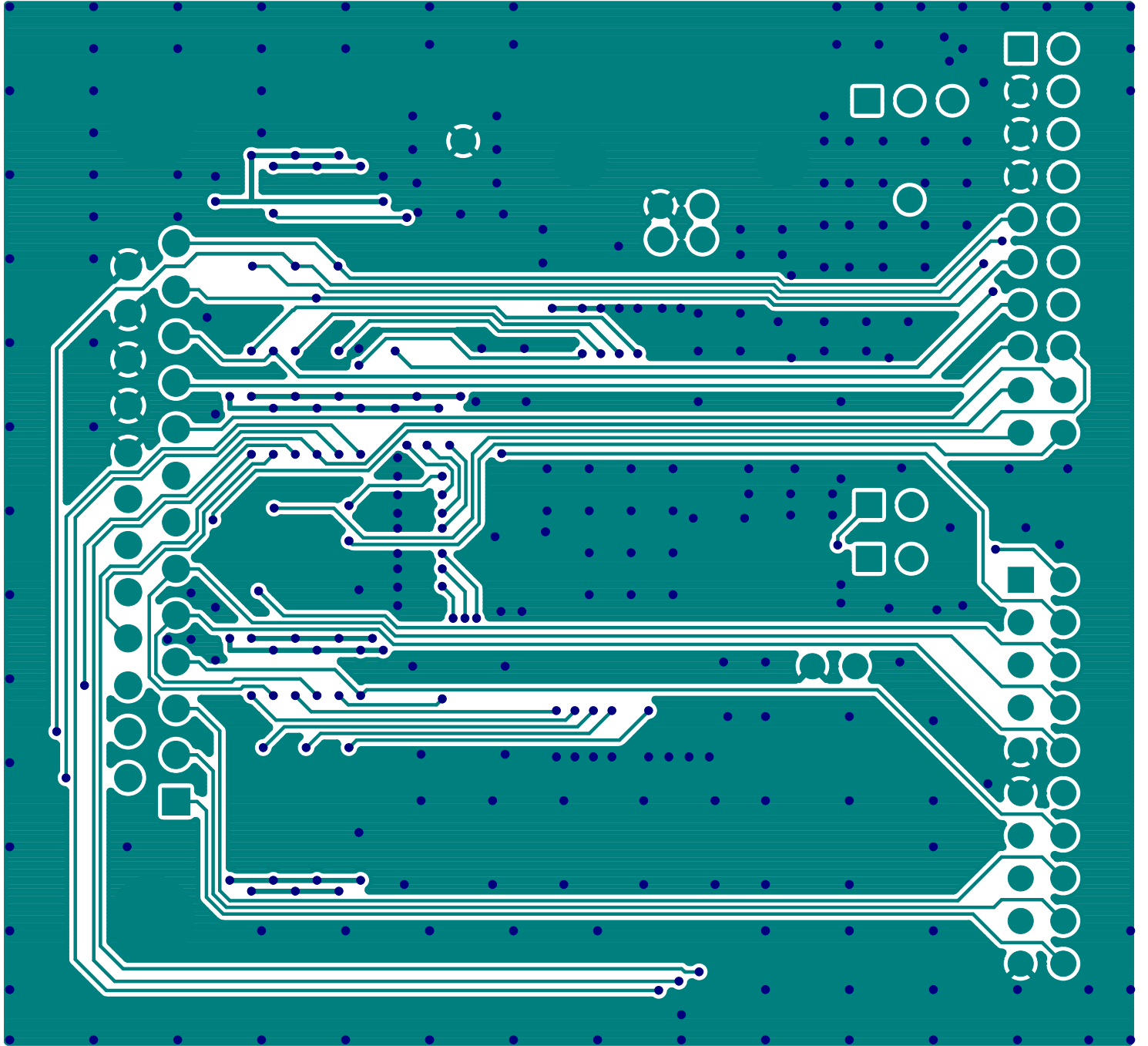

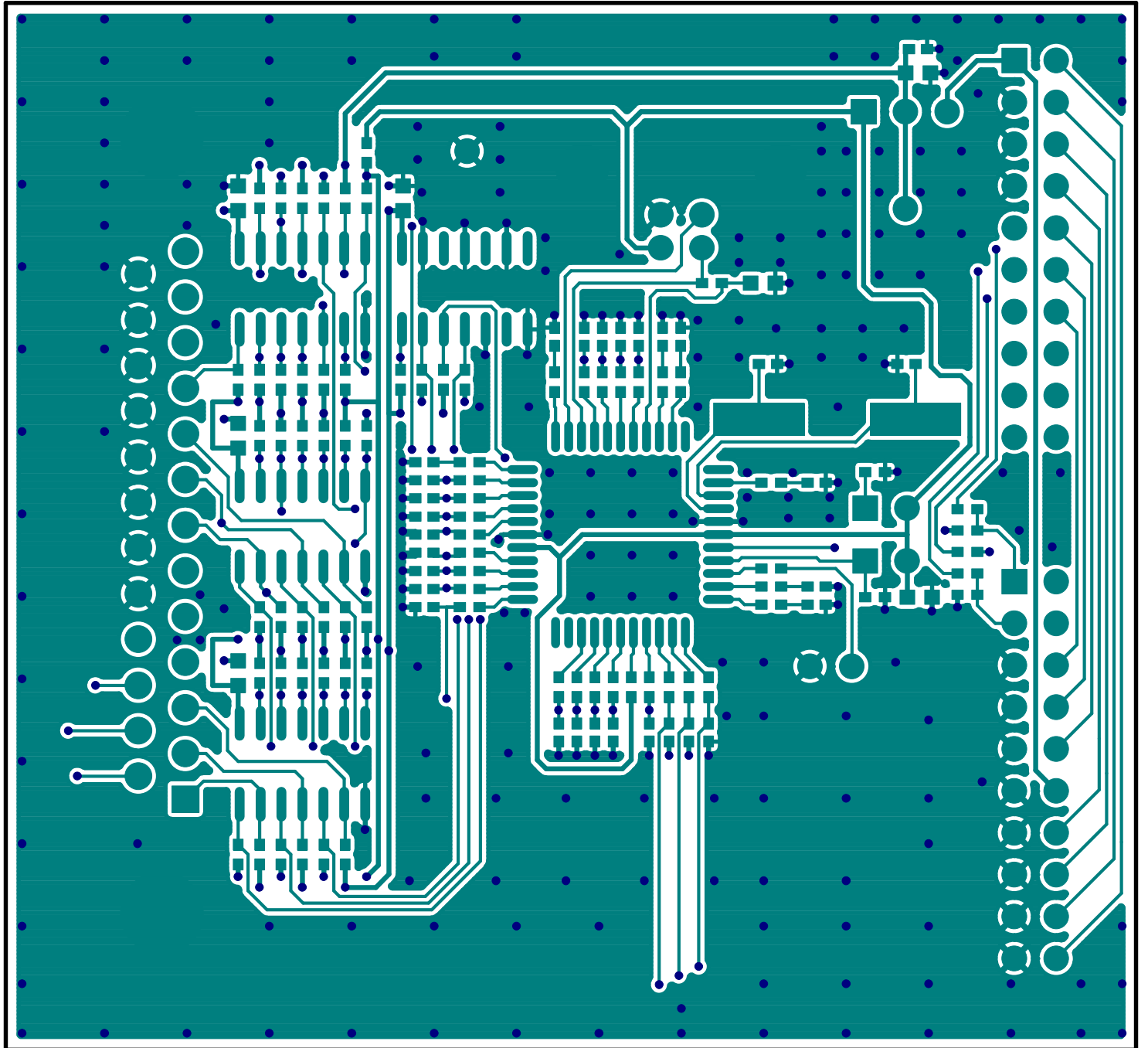

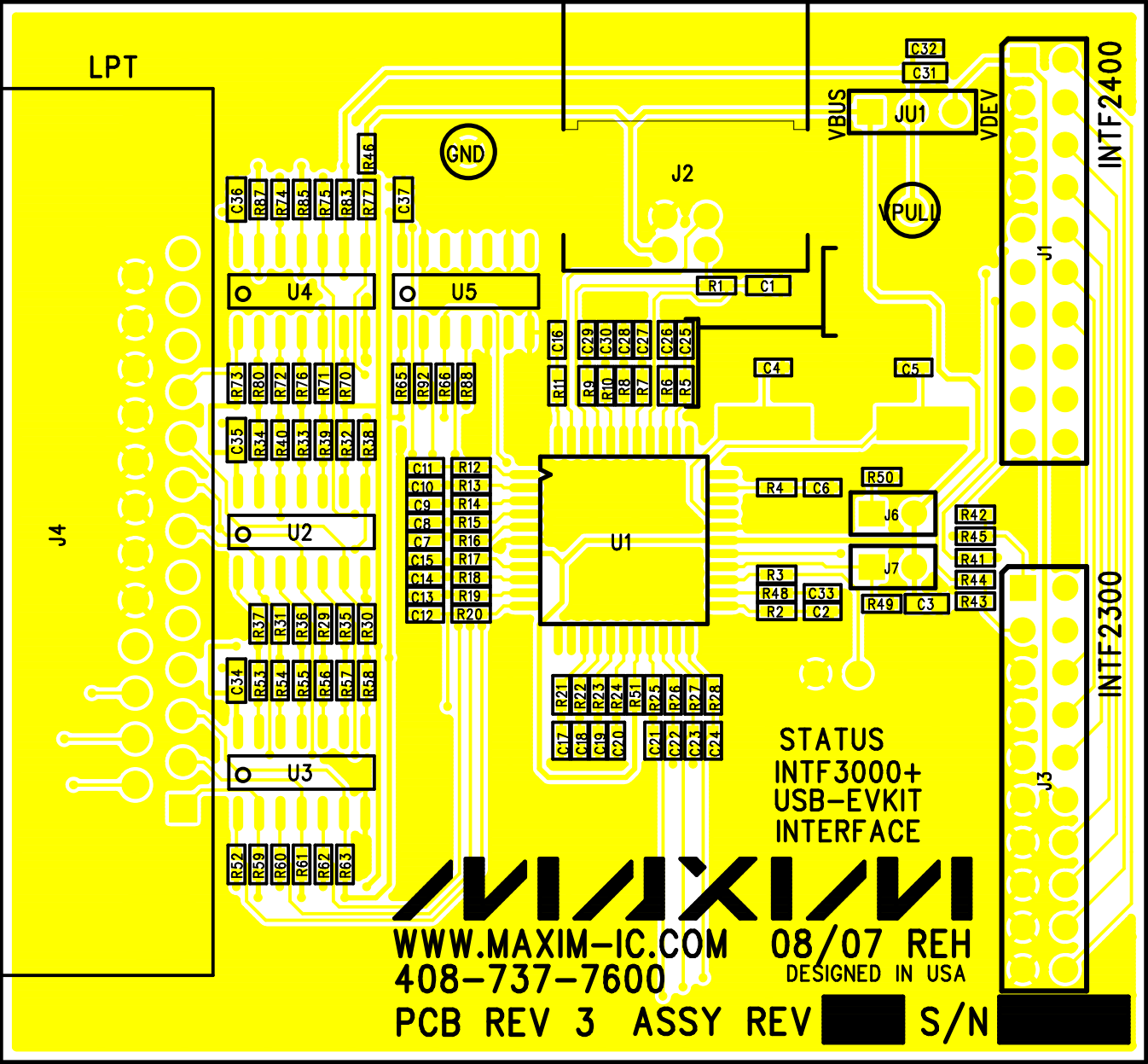

LPT

J4

U4

U2

U3

U5

U1

GND

J2

VBUS

VDEV

PUL1

INTF2400

INTF2300

STATUS
INTF 3000+
USB-EVKIT
INTERFACE



WWW.MAXIM-IC.COM

08/07 REH

408-737-7600

DESIGNED IN USA

PCB REV 3 ASSY REV

S/N

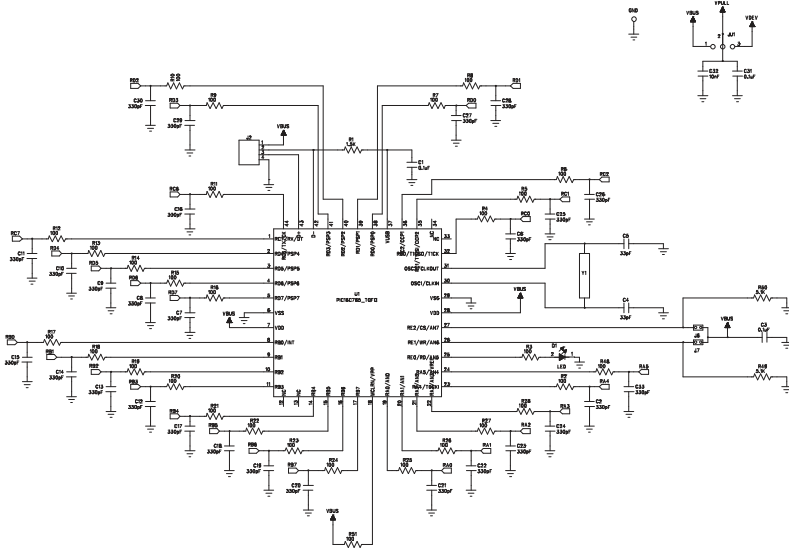

DD

