

6

5

4

3

2

1

APPROVED: _____

DATE: _____ TITLE: _____

Rev	AWO #	Description	Date	Appr
-		RELEASED	11/23/18	
A		ADDED DRAWING	9/5/19	LH/RC

D

D

C

C

B

B

A

A

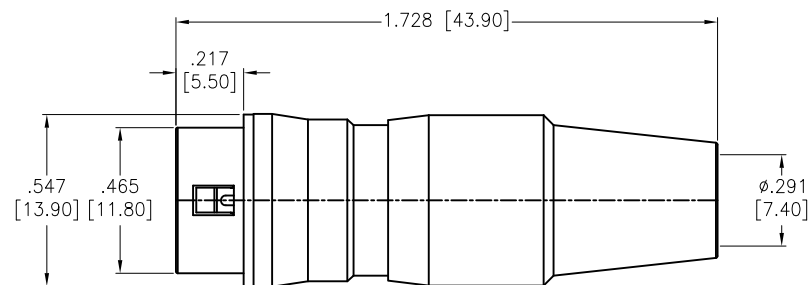
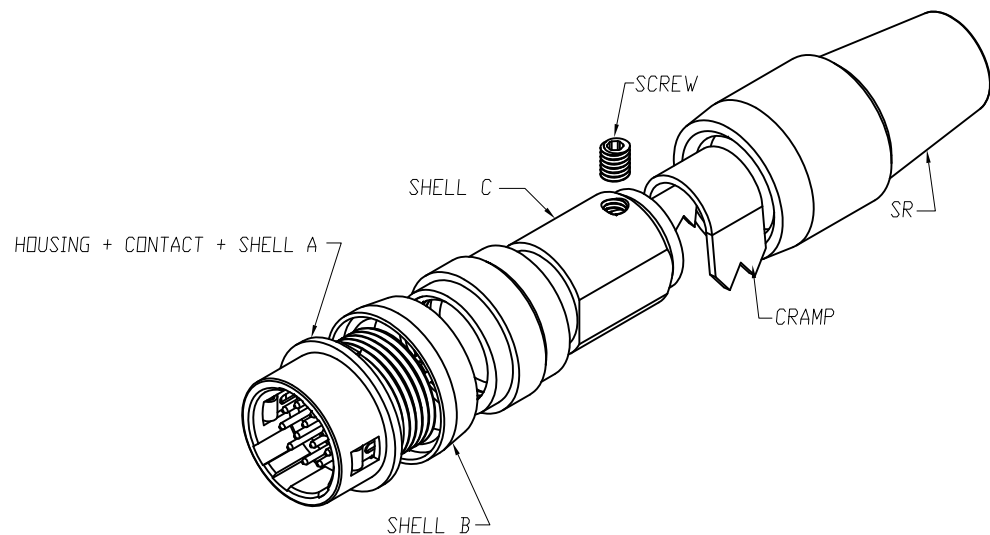

SD-PNNXX-MMLAL-S00-000

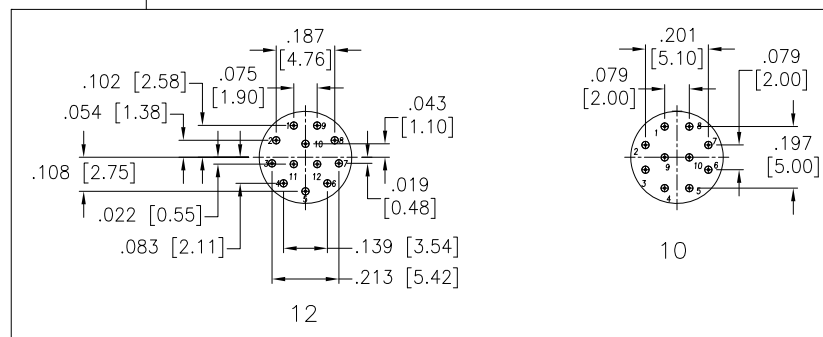

SPECIFICATIONS:

- Material:
- Housing: Nylon 46, rated UL 94V-0, Color: Black
- Contacts: Brass, Gold Flash plated
- Shell A: Zinc Alloy, Nickel plated
- Shell B: Brass, Nickel plated
- Shell C: Brass, Nickel plated
- Screw: Alloy Steel, Nickel plated
- Clamp: Brass
- SR: TPR, Color: Black
- Environmental:
- Lead free, RoHS compliant



UNLESS OTHERWISE SPECIFIED ALL DIMENSIONS ARE INCHES [MM] TOLERANCES: EXCEPT AS NOTED		ADAM TECH		909 Rahway Avenue, Union, NJ 07083 Phone: 908-687-5000 Fax: 908-687-5710	
INCHES		HOLES		TITLE	
.X ± .10	∅X ± .10	WATERPROOF CONNECTOR, MALE DIN, ASSEMBLY, SHELL LOCK TYPE, SOLDER			
.XX ± .020	∅XX ± .015	APPROVALS		DATE	
.XXX ± .015	∅XXX ± .010	DRAWN	HR	11/23/18	
		CHECKED	AC	11/23/18	
		APPROVED			
SIZE	PART NO.	REV.			
X	SD-PNNXX-MMLAL-S00-000	A			
REF:	S00298T	SCALE:	NTS	SHEET 1 OF 2	

6

5

4

3

2

1

6

5

4

3

2

1

APPROVED: _____
DATE: _____ TITLE: _____

Rev	AWO #	Description	Date	Appr
-----	-------	-------------	------	------

SEE SHT 1 OF 2 FOR REVISION

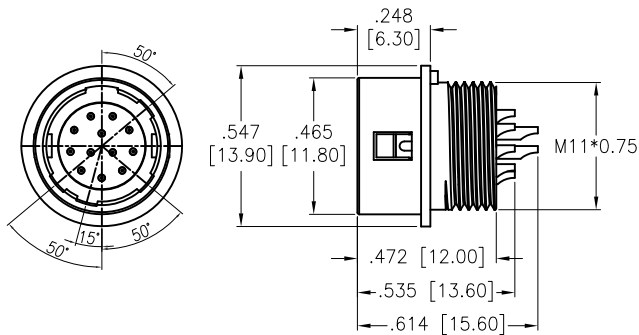

HOUSING + CONTACT + SHELL A

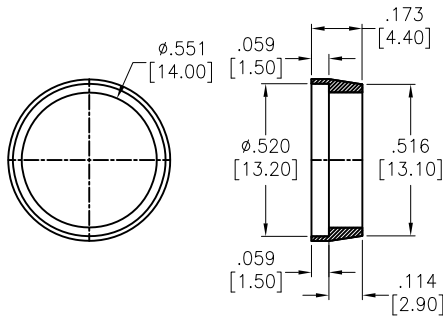

SHELL B

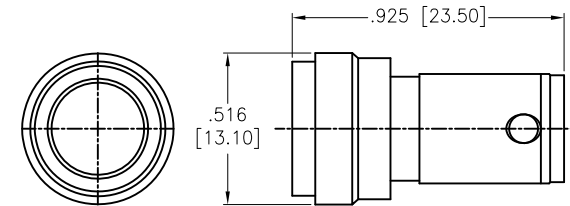

SHELL C

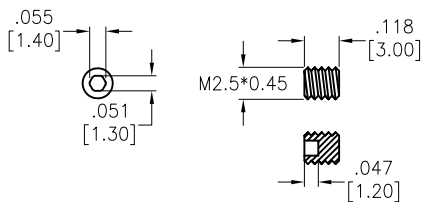

SCREW

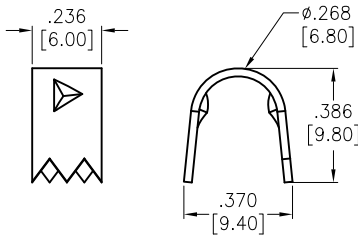

CRAMP

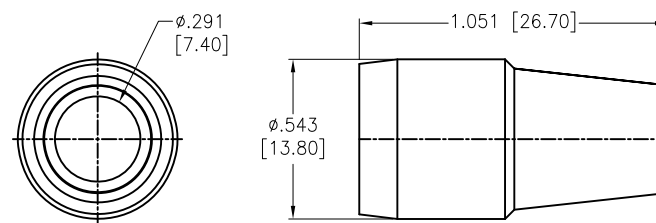

SR

UNLESS OTHERWISE SPECIFIED
ALL DIMENSIONS ARE INCHES [MM]
TOLERANCES: EXCEPT AS NOTED

INCHES		HOLES	
.X	± .10	Ø.X	± .10
.XX	± .020	Ø.XX	± .015
.XXX	± .015	Ø.XXX	± .010

ADAM TECH INTERCONNECTS
909 Rahway Avenue,
Union, NJ 07083
Phone: 908-687-5000
Fax: 908-687-5710

TITLE WATERPROOF CONNECTOR, MALE DIN, ASSEMBLY, SHELL LOCK TYPE, SOLDER

APPROVALS		DATE
DRAWN	HR	11/23/18
CHECKED	AC	11/23/18
APPROVED		

SIZE X	PART NO. SD-PNNXX-MMLAL-SX0-000	REV. A
REF: S00298T	SCALE: NTS	SHEET 2 OF 2

6

5

4

3

2

1