

THIS DRAWING IS UNPUBLISHED. RELEASED FOR PUBLICATION
 © COPYRIGHT BY TYCO ELECTRONICS CORPORATION. ALL RIGHTS RESERVED.

LOC	DIST	REVISIONS			
P	LTR	DESCRIPTION	DATE	DWN	APVD
AF	50	D2	REVISED PER ECR-22-155207	14OCT2022	PC KR

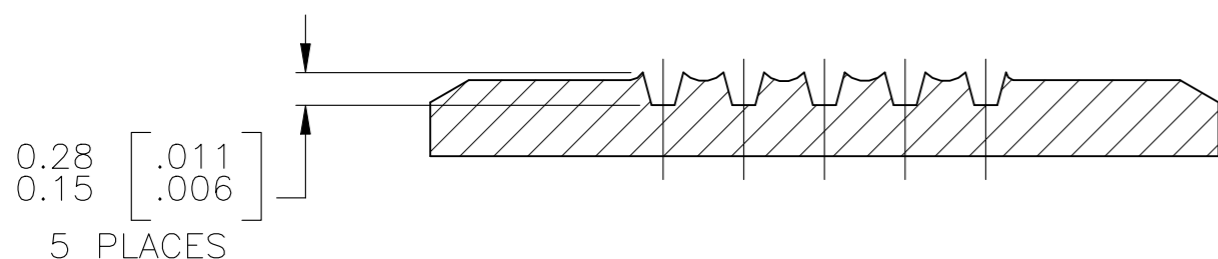
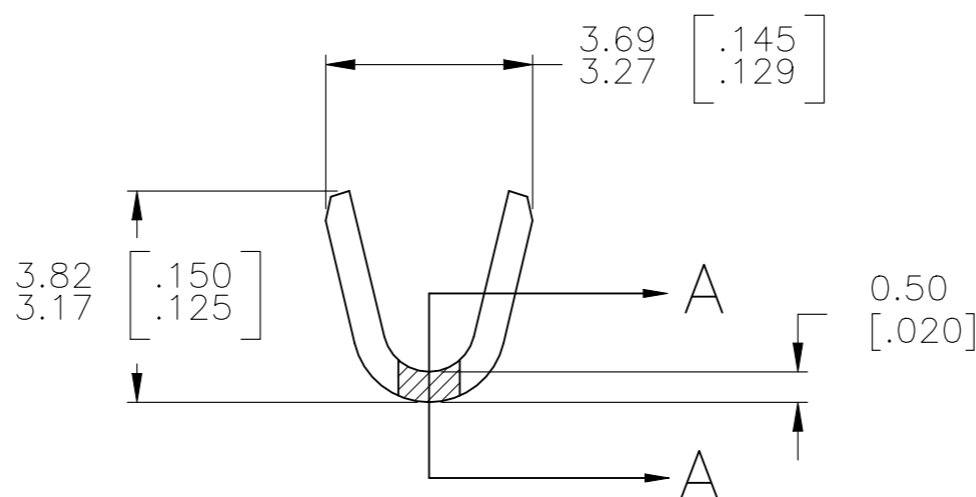
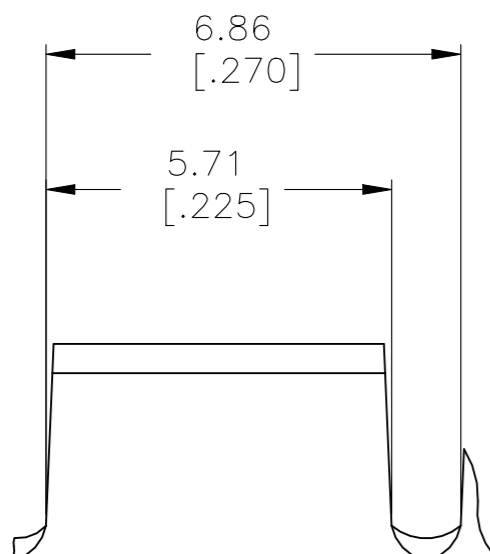
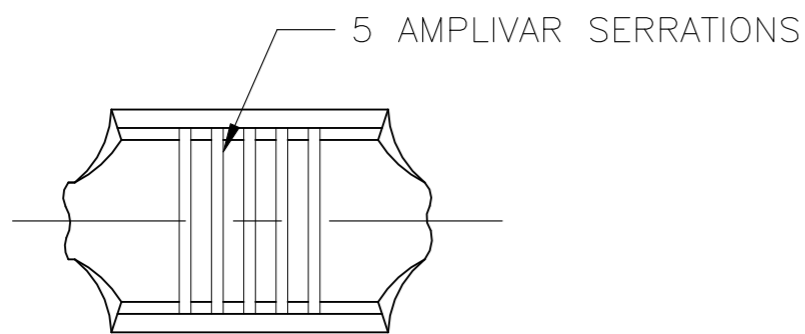

SECTION A-A
SCALE 20:1

- CONTINUOUS STRIP ON REELS.
- DIMENSIONS IN BRACKETS ARE IN INCHES.
- FOR ADDITIONAL INFORMATION, SEE APPLICATION SPEC. 114-2009.
- WIRE RANGE: 600-3000 CMA.
- CRIMP WIDTH: .110 F TYPE (AMPLIVAR THRU)
 CRIMP HEIGHT (± 0.002) = (TOTAL CMA + 9,400) / 190,500
 GENERAL APPLICATION GUIDELINES MUST BE FOLLOWED AS SPECIFIED IN CATALOG #82221
 FOR APPLICATOR INFORMATION CALL: 1-800-722-1111
 FOR PRODUCT INFORMATION CALL: 1-800-522-6752

OBSOLETE	TIN PLATE	0.51 [.020] PH BRZ	42076-3
OBSOLETE	-	0.51 [.020] PH BRZ	42076-2
	TIN PLATE	0.51 [.020] BRASS	42076-1
	-	0.51 [.020] BRASS	42076-0
	FINISH	MATERIAL	PART NO

THIS DRAWING IS A CONTROLLED DOCUMENT.		DWN RAGHAVENDRA 07JUL06	STE TE Connectivity	
DIMENSIONS: mm [INCHES]		CHK G.D.PORTA		
TOLERANCES UNLESS OTHERWISE SPECIFIED:		APVD G.D.PORTA	NAME	
0 PLC ± -		PRODUCT SPEC	SPLICE, AMPLIVAR	
1 PLC ± -		APPLICATION SPEC	RESTRICTED TO	
2 PLC ± -		WEIGHT -	SIZE A3	CAGE CODE 00779
3 PLC ± 0.38 [.015]			DRAWING NO C-42076	
4 PLC ± -			SCALE 8:1	SHEET 1 OF 1
ANGLES ± 1° 0'			REV D2	
MATERIAL SEE TABLE	FINISH SEE TABLE	CUSTOMER DRAWING		