



# Force-Sense Switches

MAX4554/MAX4555/MAX4556

## General Description

The MAX4554/MAX4555/MAX4556 are CMOS analog ICs configured as force-sense switches for Kelvin sensing in automated test equipment (ATE). Each part contains high-current, low-resistance switches for forcing current, and higher resistance switches for sensing a voltage or switching guard signals. The MAX4554 contains two force switches, two sense switches, and two guard switches configured as two triple-pole/single-throw (3PST) normally open (NO) switches. The MAX4555 contains four independent single-pole/single-throw (SPST) normally closed (NC) switches, two force switches, and two sense switches. The MAX4556 contains three independent single-pole/double-throw (SPDT) switches, of which one is a force switch and two are sense switches.

These devices operate from a single supply of +9V to +40V or dual supplies of ±4.5V to ±20V. On-resistance (6Ω max) is matched between switches to 1Ω max. Each switch can handle Rail-to-Rail® analog signals. The off-leakage current is only 0.25nA at +25°C and 2.5nA at +85°C. The MAX4554 is also fully specified for +20V and -10V operation.

All digital inputs have +0.8V and +2.4V logic thresholds, ensuring both TTL- and CMOS-logic compatibility.

## Applications

- Automated Test Equipment (ATE)
- Calibrators
- Precision Power Supplies
- Automatic Calibration Circuits
- Asymmetric Digital Subscriber Line (ADSL) with Loopback

## Features

- ◆ 6Ω Force Signal Paths (±15V Supplies)
- ◆ 1Ω Force Signal Matching (±15V Supplies)
- ◆ 60Ω Sense-Guard Signal Paths (±15V Supplies)
- ◆ 8Ω Sense-Guard Signal Matching (±15V Supplies)
- ◆ Rail-to-Rail Signal Handling
- ◆ Break-Before-Make Switching (MAX4556)
- ◆ tON and tOFF = 275ns (±15V Supplies)
- ◆ Low 1μA Power Consumption
- ◆ >2kV ESD Protection per Method 3015.7
- ◆ TTL/CMOS-Compatible Inputs

## Ordering Information

PART	TEMP. RANGE	PIN-PACKAGE
MAX4554CPE	0°C to +70°C	16 Plastic DIP
MAX4554CSE	0°C to +70°C	16 Narrow SO
MAX4554C/D	0°C to +70°C	Dice*
MAX4554EPE	-40°C to +85°C	16 Plastic DIP
MAX4554ESE	-40°C to +85°C	16 Narrow SO

Ordering Information continued at end of data sheet.  
\*Contact factory for availability.

Rail-to-Rail is a registered trademark of Nippon Motorola Ltd.

## Pin Configurations/Functional Diagrams/Truth Tables

TOP VIEW

DIP/SO

MAX4554					
EN	IN1	IN2	COMG	COMS	COMF*
1	X	X	OFF	OFF	OFF
0	0	0	OFF	OFF	OFF
0	0	1	NOG2	NOS2	NOF2*
0	1	0	NOG1	NOS1	NOF1*
0	1	1	NOG1 & NOG2	NOS1 & NOS2	NOF1* & NOF2*

NOTE: SWITCH POSITIONS SHOWN WITH IN<sub>1</sub> = LOW  
\*INDICATES HIGH-CURRENT, LOW-RESISTANCE FORCE SWITCH  
X = DON'T CARE

**MAX4555/MAX4556 shown at end of data sheet.**



# Force-Sense Switches

## ABSOLUTE MAXIMUM RATINGS

(Voltages referenced to GND)

V+	.....-0.3V to +44V
V-	.....-25V to +0.3V
V+ to V-	.....-0.3V to +44V
All Other Pins (Note 1)	.....(V- - 0.3V) to (V+ + 0.3V)
Continuous Current into Force Terminals	.....±100mA
Continuous Current into Any Other Terminal	.....±30mA
Peak Current into Force Terminals (pulsed at 1ms, 10% duty cycle)	.....±300mA
Peak Current into Any Other Terminal (pulsed at 1ms, 10% duty cycle)	.....±100mA

ESD per Method 3015.7	.....>2000V
Continuous Power Dissipation (T <sub>A</sub> = +70°C)	
Plastic DIP (derate 10.53mW/°C above +70°C)	.....842mW
Narrow SO (derate 8.7mW/°C above +70°C)	.....696mW
Operating Temperature Ranges	
MAX455_C_E	.....0°C to +70°C
MAX455_E_E	.....-40°C to +85°C
Storage Temperature Range	.....-65°C to +150°C
Lead Temperature (soldering, 10sec)	.....+300°C

**Note 1:** Signals on analog or digital pins exceeding V+ or V- are clamped by internal diodes. Limit forward diode current to maximum current rating.

Stresses beyond those listed under "Absolute Maximum Ratings" may cause permanent damage to the device. These are stress ratings only, and functional operation of the device at these or any other conditions beyond those indicated in the operational sections of the specifications is not implied. Exposure to absolute maximum rating conditions for extended periods may affect device reliability.

## ELECTRICAL CHARACTERISTICS—MAX4554 (+20V, -10V Supplies)

(V+ = +20V, V- = -10V, V<sub>L</sub> = 5V, GND = 0V, V<sub>IN\_H</sub> = 2.4V, V<sub>IN\_L</sub> = 0.8V, T<sub>A</sub> = T<sub>MIN</sub> to T<sub>MAX</sub>, unless otherwise noted. Typical values are at T<sub>A</sub> = +25°C.)

PARAMETER	SYMBOL	CONDITIONS	T <sub>A</sub>	MIN	TYP (Note 2)	MAX	UNITS
<b>6Ω ANALOG SWITCH (FORCE)</b>							
Analog Signal Range	V <sub>COMF</sub> , V <sub>NOF_</sub>	(Note 3)	C, E	V-		V+	V
On-Resistance	R <sub>ON</sub>	V <sub>COMF</sub> = 10V, I <sub>COMF</sub> = 10mA	+25°C C, E		3.5 7	6	Ω
On-Resistance Match (Note 4)	ΔR <sub>ON</sub>	V <sub>COMF</sub> = 10V, I <sub>COMF</sub> = 10mA	+25°C C, E		0.4 1.5	1	Ω
On-Resistance Flatness (Note 5)	R <sub>FLAT(ON)</sub>	V <sub>COMF</sub> = +5V, 0V, -5V; I <sub>COMF</sub> = 10mA	+25°C C, E		0.5 2.0	1.5	Ω
NOF_ Off-Leakage Current	I <sub>NOF_(OFF)</sub>	V+ = 22V, V- = -11V, V <sub>COMF</sub> = ±10V, V <sub>NOF_</sub> = ∓10V	+25°C C, E	-0.25 -2.5	0.03	0.25 2.5	nA
COMF Off-Leakage Current	I <sub>COMF(OFF)</sub>	V+ = 22V, V- = -11V, V <sub>COMF</sub> = ±10V, V <sub>NOF_</sub> = ∓10V	+25°C C, E	-0.5 -2.5	0.03	0.5 2.5	nA
COMF On-Leakage Current	I <sub>COMF(ON)</sub>	V+ = 22V, V- = -11V, V <sub>COMF</sub> = ±10V	+25°C C, E	-0.5 -10	0.06	0.5 10	nA
Charge Injection	Q	V <sub>COMF</sub> = 0, Figure 13	C, E		80		pC
<b>60Ω ANALOG SWITCH (SENSE-GUARD)</b>							
Analog Signal Range	V <sub>COMS</sub> , V <sub>COMG</sub> , V <sub>NOS_</sub> , V <sub>NOG_</sub>	(Note 3)	C, E	V-		V+	V
On-Resistance	R <sub>ON</sub>	V <sub>COM_</sub> = 10V, I <sub>COM_</sub> = 1mA	+25°C C, E		34 70	60	Ω
On-Resistance Match (Note 4)	ΔR <sub>ON</sub>	V <sub>COM_</sub> = 10V, I <sub>COM_</sub> = 1mA	+25°C C, E		5 10	8	Ω

# Force-Sense Switches

MAX4554/MAX4555/MAX4556

## ELECTRICAL CHARACTERISTICS—MAX4554 (+20V, -10V Supplies) (continued)

(V+ = +20V, V- = -10V, VL = 5V, GND = 0V, VIN\_H = 2.4V, VIN\_L = 0.8V, TA = TMIN to TMAX, unless otherwise noted. Typical values are at TA = +25°C.)

PARAMETER	SYMBOL	CONDITIONS	TA	MIN	TYP (Note 2)	MAX	UNITS
On-Resistance Flatness (Note 5)	R <sub>FLAT(ON)</sub>	V <sub>COM_</sub> = +5V, 0V, -5V; I <sub>COM_</sub> = 10mA	+25°C C, E		3.5	9 10	Ω
NOS_, NOG_ Off-Leakage Current	I <sub>NOS_(OFF)</sub> , I <sub>NOG_(OFF)</sub>	V+ = 22V; V- = -11V; V <sub>COM_</sub> = ±10V; V <sub>NOS_</sub> , V <sub>NOG_</sub> = ±10V	+25°C C, E	-0.25 -2.5	0.02	0.25 2.5	nA
COMS, COMG Off-Leakage Current	I <sub>COMS(OFF)</sub> , I <sub>COMG(OFF)</sub>	V+ = 22V; V- = -11V; V <sub>COM_</sub> = ±10V; V <sub>NOS_</sub> , V <sub>NOG_</sub> = ±10V	+25°C C, E	-0.25 -2.5	0.02	0.25 2.5	nA
COMS, COMG On-Leakage Current	I <sub>COMS(ON)</sub> , I <sub>COMG(ON)</sub>	V+ = 22V, V- = -11V, V <sub>COM_</sub> = ±10V	+25°C C, E	-0.5 -5.0	0.04	0.5 5.0	nA
Charge Injection	Q	V <sub>COM_</sub> = 0, Figure 13	+25°C		6		pC
<b>LOGIC INPUT</b>							
IN_, EN Input Logic Threshold High	V <sub>IN_H</sub> , V <sub>ENH</sub>		C, E		1.6	2.4	V
IN_, EN Input Logic Threshold Low	V <sub>IN_L</sub> , V <sub>ENL</sub>		C, E	0.8	1.6		V
IN_, EN Input Current Logic High or Low	I <sub>IN_H</sub> , I <sub>IN_L</sub> , I <sub>ENH</sub> , I <sub>ENL</sub>	V <sub>IN_</sub> = V <sub>EN_</sub> = 0 or VL	C, E	-0.5	0.03	0.5	μA
<b>SWITCH DYNAMIC CHARACTERISTICS</b>							
Turn-On Time (Force)	t <sub>ON</sub>	V <sub>COMF</sub> = 3V, R <sub>L</sub> = 300Ω, Figure 10	+25°C C, E		150	300 350	ns
Turn-On Time (Sense-Guard)	t <sub>ON</sub>	V <sub>COMS</sub> , V <sub>COMG</sub> = 10V; R <sub>L</sub> = 1kΩ; Figure 10	+25°C C, E		150	300 350	ns
Turn-Off Time (Force)	t <sub>OFF</sub>	V <sub>COMF</sub> = 3V, R <sub>L</sub> = 300Ω, Figure 10	+25°C C, E		130	300 350	ns
Turn-Off Time (Sense-Guard)	t <sub>OFF</sub>	V <sub>COMS</sub> , V <sub>COMG</sub> = 10V; R <sub>L</sub> = 1kΩ; Figure 10	+25°C C, E		130	300 350	ns
Enable Time On	t <sub>EN</sub>	V <sub>COM_</sub> = 10V, Figure 11	+25°C C, E		375	500 600	ns
Enable Time Off	t <sub>EN</sub>	V <sub>COM_</sub> = 10V, Figure 11	+25°C C, E		170	275 350	ns
NOF_ Off-Capacitance	C <sub>OFF</sub>	V <sub>NOF</sub> = GND, f = 1MHz, Figure 14	+25°C		22		pF
NOS_, NOG_ Off-Capacitance	C <sub>OFF</sub>	V <sub>NOS_</sub> , V <sub>NOG_</sub> = GND; f = 1MHz; Figure 14	+25°C		7		pF
COMF Off-Capacitance	C <sub>OFF</sub>	V <sub>COMF</sub> = GND, f = 1MHz, Figure 14	+25°C		50		pF
COMS, COMG Off-Capacitance	C <sub>OFF</sub>	V <sub>COMS</sub> , V <sub>COMG</sub> = GND; f = 1MHz; Figure 14	+25°C		15		pF
COMF On-Capacitance	C <sub>ON</sub>	V <sub>COMF</sub> = GND, f = 1MHz, Figure 14	+25°C		130		pF
COMS, COMG On-Capacitance	C <sub>ON</sub>	V <sub>COMS</sub> , V <sub>COMG</sub> = GND; f = 1MHz; Figure 14	+25°C		30		pF
Total Harmonic Distortion (Force)	THD		+25°C		0.007		%
Off Isolation (Force)	V <sub>ISO</sub>	R <sub>IN_</sub> = 50Ω, R <sub>OUT</sub> = 50Ω, f = 1MHz, V <sub>COM_</sub> = 100mV <sub>RMS</sub> , Figure 15	+25°C		-30		dB

# Force-Sense Switches

## ELECTRICAL CHARACTERISTICS—MAX4554 (+20V, -10V Supplies) (continued)

(V+ = +20V, V- = -10V, VL = 5V, GND = 0V, VIN\_H = 2.4V, VIN\_L = 0.8V, TA = TMIN to TMAX, unless otherwise noted. Typical values are at TA = +25°C.)

PARAMETER	SYMBOL	CONDITIONS	TA	MIN	TYP (Note 2)	MAX	UNITS
<b>POWER SUPPLY</b>							
Power-Supply Range	V+, VL, V-	VL ≥ 4.5V	C, E	±4.5		±20	V
V+ Supply Current	I+	V+ = 22V; V- = -11V; VEN, VIN_ = 0 or VL	+25°C	-1.0		1.0	μA
			C, E	-5.0		5.0	
V- Supply Current	I-	V+ = 22V; V- = -11V; VEN, VIN_ = 0 or VL	+25°C	-1.0		1.0	μA
			C, E	-5.0		5.0	
VL Supply Current	IL+	V+ = 22V; V- = -11V; VEN, VIN_ = 0 or VL	+25°C	-1.0		1.0	μA
			C, E	-5.0		5.0	
Ground Current	IGND	V+ = 22V; V- = -11V; VEN, VIN_ = 0 or VL	+25°C	-1.0		1.0	μA
			C, E	-5.0		5.0	

## ELECTRICAL CHARACTERISTICS—MAX4554 (±15V Supplies)

(V+ = +15V, V- = -15V, VL = 5V, GND = 0V, VIN\_H = 2.4V, VIN\_L = 0.8V, TA = TMIN to TMAX, unless otherwise noted. Typical values are at TA = +25°C.)

PARAMETER	SYMBOL	CONDITIONS	TA	MIN	TYP (Note 2)	MAX	UNITS
<b>6Ω ANALOG SWITCH (FORCE)</b>							
Analog Signal Range	VCOMF, VNOF_	(Note 3)	C, E	V-		V+	V
On-Resistance	RON	VCOMF = ±10V, ICOMF = 10mA	+25°C		4	6	Ω
			C, E			7	
On-Resistance Match (Note 4)	ΔRON	VCOMF = ±10V, ICOMF = 10mA	+25°C		0.5	1	Ω
			C, E			1.5	
On-Resistance Flatness (Note 5)	RFLAT(ON)	VCOMF = +5V, 0V, -5V; ICOMF = 10mA	+25°C		0.1	1	Ω
			C, E			1.5	
NOF_ Off-Leakage Current	INOF_(OFF)	V+ = 16.5V, V- = -16.5V, VCOMF = ±10V, VNOF_ = ∓10V	+25°C	-0.25	0.03	0.25	nA
			C, E	-2.5		2.5	
COMF Off-Leakage Current	ICOMF(OFF)	V+ = 16.5V, V- = -16.5V, VCOMF = ±10V, VNOF_ = ∓10V	+25°C	-0.5	0.03	0.5	nA
			C, E	-5.0		5.0	
COMF On-Leakage Current	ICOMF(ON)	V+ = 16.5V, V- = -16.5V, VCOMF = ±10V	+25°C	-0.5	0.06	0.5	nA
			C, E	-10		10	
Charge Injection	Q	VCOMF = 0, Figure 13	+25°C		100		pC
<b>60Ω ANALOG SWITCH (SENSE-GUARD)</b>							
Analog Signal Range	VCOMS, VCOMG, VNOS_, VNOG_	(Note 3)	C, E	V-		V+	V
On-Resistance	RON	VCOM_ = ±10V, ICOM_ = 1mA	+25°C		38	60	Ω
			C, E			70	

# Force-Sense Switches

MAX4554/MAX4555/MAX4556

## ELECTRICAL CHARACTERISTICS—MAX4554 (±15V Supplies) (continued)

(V+ = +15V, V- = -15V, VL = 5V, GND = 0V, VIN\_H = 2.4V, VIN\_L = 0.8V, TA = TMIN to TMAX, unless otherwise noted. Typical values are at TA = +25°C.)

PARAMETER	SYMBOL	CONDITIONS	TA	MIN	TYP (Note 2)	MAX	UNITS
On-Resistance Match (Note 4)	$\Delta R_{ON}$	VCOM_ = ±10V, ICOM_ = 1mA	+25°C C, E		5	9 10	$\Omega$
On-Resistance Flatness (Note 5)	RFLAT(ON)	VCOM_ = +5V, 0V, -5V; ICOM_ = 1mA	+25°C C, E		1.5	5 6	$\Omega$
NOS_ , NOG Off-Leakage Current	INOS_(OFF), INOG_(OFF)	V+ = 16.5V; V- = -16.5V; VCOM_ = ±10V; VNOS_ , VNOG_ = $\mp$ 10V	+25°C C, E	-0.25 -2.5	0.01	0.25 2.5	nA
COMS, COMG Off-Leakage Current	ICOMS(OFF), ICOMG(OFF)	V+ = 16.5V; V- = -16.5V; VCOM_ = ±10V; VNOS_ , VNOG_ = $\mp$ 10V	+25°C C, E	-0.25 -2.5	0.01	0.25 2.5	nA
COMS, COMG On-Leakage Current	ICOMS(ON), ICOMG(ON)	V+ = 16.5V, V- = -16.5V, VCOM_ = ±10V	+25°C C, E	-0.5 -5.0	0.02	0.5 5.0	nA
Charge Injection	Q	VCOM_ = 0, Figure 13	+25°C		4		pC
<b>LOGIC INPUT</b>							
IN_ , $\overline{EN}$ Input Logic Threshold High	VIN_H, VENH		C, E		1.6	2.4	V
IN_ , $\overline{EN}$ Input Logic Threshold Low	VIN_L, VENL		C, E	0.8	1.6		V
IN_ , $\overline{EN}$ Input Current Logic High or Low	IIN_H, IIN_L, IENH, IENL	V $\overline{EN}$ = 0 or VL	C, E	-0.5	0.03	0.5	$\mu$ A
<b>SWITCH DYNAMIC CHARACTERISTICS</b>							
Turn-On Time (Force)	tON	VCOM_ = ±10V, RL = 300 $\Omega$ , Figure 10	+25°C C, E		135	275 325	ns
Turn-On Time (Sense-Guard)	tON	VCOM_ = ±10V, RL = 1k $\Omega$ , Figure 10	+25°C C, E		135	225 275	ns
Turn-Off Time (Force)	tOFF	VCOM_ = ±10V, RL = 300 $\Omega$ , Figure 10	+25°C C, E		170	275 325	ns
Turn-Off Time (Sense-Guard)	tOFF	VCOM_ = ±10V, RL = 1k $\Omega$ , Figure 10	+25°C C, E		135	225 275	ns
Enable Time On	tEN	VCOM_ = ±10V, RL = 300 $\Omega$ , Figure 11	+25°C C, E		310	500 600	ns
Enable Time Off	tEN	VCOM_ = ±10V, RL = 300 $\Omega$ , Figure 11	+25°C C, E		170	300 400	ns
NOF_ Off-Capacitance	COFF	VNOF = GND, f = 1MHz, Figure 14	+25°C		22		pF
NOS_ , NOG_ Off-Capacitance	COFF	VNOS_ , VNOG_ = GND; f = 1MHz; Figure 14	+25°C		9		pF
COMF Off-Capacitance	COFF	VCOMF = GND, f = 1MHz, Figure 14	+25°C		29		pF
COMS, COMG Off-Capacitance	COFF	VCOMS_ , VCOMG_ = GND; f = 1MHz; Figure 14	+25°C		9		pF

# Force-Sense Switches

## ELECTRICAL CHARACTERISTICS—MAX4554 (±15V Supplies) (continued)

(V<sub>+</sub> = +15V, V<sub>-</sub> = -15V, V<sub>L</sub> = 5V, GND = 0V, V<sub>IN\_H</sub> = 2.4V, V<sub>IN\_L</sub> = 0.8V, T<sub>A</sub> = T<sub>MIN</sub> to T<sub>MAX</sub>, unless otherwise noted. Typical values are at T<sub>A</sub> = +25°C.)

PARAMETER	SYMBOL	CONDITIONS	T <sub>A</sub>	MIN	TYP (Note 2)	MAX	UNITS
COMF On-Capacitance	C <sub>ON</sub>	V <sub>COMF</sub> = GND, f = 1MHz, Figure 14	+25°C		107		pF
COMS, COMG On-Capacitance	C <sub>ON</sub>	V <sub>COMS</sub> , V <sub>COMG</sub> = GND; f = 1MHz; Figure 14	+25°C		29		pF
Total Harmonic Distortion (Force)	THD		+25°C		0.007		%
Off Isolation (Force)	V <sub>ISO</sub>	R <sub>IN</sub> = 50Ω, R <sub>OUT</sub> = 50Ω, f = 1MHz, V <sub>COM</sub> = 100mV <sub>RMS</sub> , Figure 15	+25°C		-30		dB
<b>POWER SUPPLY</b>							
Power-Supply Range	V <sub>+</sub> , V <sub>L</sub> , V <sub>-</sub>	V <sub>L</sub> ≥ 4.5V	C, E	±4.5		±20	V
V <sub>+</sub> Supply Current	I <sub>+</sub>	V <sub>+</sub> = 16.5V; V <sub>-</sub> = -16.5V; V <sub>EN</sub> , V <sub>IN</sub> = 0 or V <sub>+</sub>	+25°C	-1.0	0.001	1.0	μA
V <sub>-</sub> Supply Current	I <sub>-</sub>	V <sub>+</sub> = 16.5V; V <sub>-</sub> = -16.5V; V <sub>EN</sub> , V <sub>IN</sub> = 0 or V <sub>+</sub>	+25°C	-1.0	0.001	1.0	μA
V <sub>L</sub> Supply Current	I <sub>L+</sub>	V <sub>+</sub> = 16.5V; V <sub>-</sub> = -16.5V; V <sub>EN</sub> , V <sub>IN</sub> = 0 or V <sub>+</sub>	+25°C	-1.0	0.001	1.0	μA
Ground Current	I <sub>GND</sub>	V <sub>+</sub> = 16.5V; V <sub>-</sub> = -16.5V; V <sub>EN</sub> , V <sub>IN</sub> = 0 or V <sub>+</sub>	+25°C	-1.0		1.0	μA
			C, E	-5.0		5.0	μA

## ELECTRICAL CHARACTERISTICS—MAX4555 (±15V Supplies)

(V<sub>+</sub> = +15V, V<sub>-</sub> = -15V, V<sub>L</sub> = 5V, GND = 0V, V<sub>IN\_H</sub> = 2.4V, V<sub>IN\_L</sub> = 0.8V, T<sub>A</sub> = T<sub>MIN</sub> to T<sub>MAX</sub>, unless otherwise noted. Typical values are at T<sub>A</sub> = +25°C.)

PARAMETER	SYMBOL	CONDITIONS	T <sub>A</sub>	MIN	TYP (Note 2)	MAX	UNITS
<b>6Ω ANALOG SWITCH (FORCE)</b>							
Analog Signal Range	V <sub>COM</sub> , V <sub>NO</sub>	(Note 3)	C, E	V <sub>-</sub>		V <sub>+</sub>	V
On-Resistance	R <sub>ON</sub>	V <sub>COM</sub> = ±10V, I <sub>COM</sub> = 10mA	+25°C		3.8	6	Ω
			C, E			7	Ω
On-Resistance Match (Note 4)	ΔR <sub>ON</sub>	V <sub>COM</sub> = ±10V, I <sub>COM</sub> = 10mA	+25°C		0.3	1	Ω
			C, E			1.5	Ω
On-Resistance Flatness (Note 5)	R <sub>FLAT(ON)</sub>	V <sub>COM</sub> = +5V, 0V, -5V; I <sub>COM</sub> = 10mA	+25°C		0.05	1	Ω
			C, E			1.5	Ω
NC <sub>-</sub> Off-Leakage Current	I <sub>NC(OFF)</sub>	V <sub>+</sub> = 16.5V, V <sub>-</sub> = -16.5V, V <sub>COM</sub> = ±10V, V <sub>NO</sub> = ∓10V	+25°C	-0.25	0.03	0.25	nA
			C, E	-2.5		2.5	nA
COM <sub>-</sub> Off-Leakage Current	I <sub>COM(OFF)</sub>	V <sub>+</sub> = 16.5V, V <sub>-</sub> = -16.5V, V <sub>COM</sub> = ±10V, V <sub>NO</sub> = ∓10V	+25°C	-0.5	0.03	0.5	nA
			C, E	-5.0		5.0	nA
COM <sub>-</sub> On-Leakage Current	I <sub>COM(ON)</sub>	V <sub>+</sub> = 16.5V, V <sub>-</sub> = -16.5V, V <sub>COM</sub> = ±10V	+25°C	-0.5	0.06	0.5	nA
			C, E	-10		10	nA
Charge Injection	Q	V <sub>COM</sub> = 0, Figure 13	+25°C		100		pC

# Force-Sense Switches

MAX4554/MAX4555/MAX4556

## ELECTRICAL CHARACTERISTICS—MAX4555 (±15V Supplies) (continued)

(V<sub>+</sub> = +15V, V<sub>-</sub> = -15V, V<sub>L</sub> = 5V, GND = 0V, V<sub>IN\_H</sub> = 2.4V, V<sub>IN\_L</sub> = 0.8V, T<sub>A</sub> = T<sub>MIN</sub> to T<sub>MAX</sub>, unless otherwise noted. Typical values are at T<sub>A</sub> = +25°C.)

PARAMETER	SYMBOL	CONDITIONS	T <sub>A</sub>	MIN	TYP (Note 2)	MAX	UNITS
<b>30Ω ANALOG SWITCH (SENSE-GUARD)</b>							
Analog Signal Range	V <sub>COM_</sub> , V <sub>NO_</sub>	(Note 3)	C, E	V-		V+	V
On-Resistance	R <sub>ON</sub>	V <sub>COM_</sub> = ±10V, I <sub>COM_</sub> = 10mA	+25°C		15	30	Ω
			C, E			45	
On-Resistance Match (Note 4)	ΔR <sub>ON</sub>	V <sub>COM_</sub> = ±10V, I <sub>COM_</sub> = 10mA	+25°C		0.6	4	Ω
			C, E			5	
On-Resistance Flatness (Note 5)	R <sub>FLAT(ON)</sub>	V <sub>COM_</sub> = +5V, 0V, -5V; I <sub>COM_</sub> = 10mA	+25°C		0.6	5	Ω
			C, E			6	
NC_Off-Leakage Current	I <sub>NC(OFF)</sub>	V <sub>+</sub> = 16.5V, V <sub>-</sub> = -16.5V, V <sub>COM_</sub> = ±10V, V <sub>NO_</sub> = ∓10V	+25°C	-0.3	0.01	0.3	nA
			C, E	-2.5		2.5	
COM_Off-Leakage Current	I <sub>COM(OFF)</sub>	V <sub>+</sub> = 16.5V, V <sub>-</sub> = -16.5V, V <sub>COM_</sub> = ±10V, V <sub>NO_</sub> = ∓10V	+25°C	-0.3	0.01	0.3	nA
			C, E	-2.5		2.5	
COM_On-Leakage Current	I <sub>NC(ON)</sub>	V <sub>+</sub> = 16.5V, V <sub>-</sub> = -16.5V, V <sub>NC_</sub> = ±10V	+25°C	-0.6	0.02	0.6	nA
			C, E	-5.0		5.0	
Charge Injection	Q	V <sub>COM_</sub> = 0, Figure 13	+25°C		4		pC
<b>LOGIC INPUT</b>							
IN_Input Logic Threshold High	V <sub>IN_H</sub>		C, E		1.6	2.4	V
IN_Input Logic Threshold Low	V <sub>IN_L</sub>		C, E	0.8	1.6		V
IN_Input Current Logic High or Low	I <sub>IN_H</sub> , I <sub>IN_L</sub>	V <sub>IN_</sub> = 0.8V or 2.4V	C, E	-0.5	0.03	0.5	μA
<b>SWITCH DYNAMIC CHARACTERISTICS</b>							
Turn-On Time (Force)	t <sub>ON</sub>	V <sub>COM_</sub> = ±3V, R <sub>L</sub> = 300Ω, Figure 10	+25°C		155	275	ns
			C, E			325	
Turn-On Time (Sense-Guard)	t <sub>ON</sub>	V <sub>COM_</sub> = ±10V, R <sub>L</sub> = 1kΩ, Figure 10	+25°C		125	225	ns
			C, E			275	
Turn-Off Time (Force)	t <sub>OFF</sub>	V <sub>COM_</sub> = ±3V, R <sub>L</sub> = 300Ω, Figure 10	+25°C		190	275	ns
			C, E			325	
Turn-Off Time (Sense-Guard)	t <sub>OFF</sub>	V <sub>COM_</sub> = ±10V, R <sub>L</sub> = 1kΩ, Figure 10	+25°C		125	225	ns
			C, E			275	
COM_Off-Capacitance (Force)	C <sub>OFF</sub>	V <sub>COM_</sub> , V <sub>NO_</sub> = GND; f = 1MHz; Figure 14	+25°C		29		pF
COM_On-Capacitance (Sense-Guard)	C <sub>ON</sub>	V <sub>COM_</sub> , V <sub>NO_</sub> = GND; f = 1MHz; Figure 14	+25°C		9		pF
COM_On-Capacitance (Force)	C <sub>ON</sub>	V <sub>COM_</sub> , V <sub>NO_</sub> = GND; f = 1MHz; Figure 14	+25°C		107		pF
COM_Off-Capacitance (Sense-Guard)	C <sub>OFF</sub>	V <sub>COM_</sub> , V <sub>NO_</sub> = GND; f = 1MHz; Figure 14	+25°C		29		pF

# Force-Sense Switches

## ELECTRICAL CHARACTERISTICS—MAX4555 (±15V Supplies) (continued)

(V<sub>+</sub> = +15V, V<sub>-</sub> = -15V, V<sub>L</sub> = 5V, GND = 0V, V<sub>IN\_H</sub> = 2.4V, V<sub>IN\_L</sub> = 0.8V, T<sub>A</sub> = T<sub>MIN</sub> to T<sub>MAX</sub>, unless otherwise noted. Typical values are at T<sub>A</sub> = +25°C.)

PARAMETER	SYMBOL	CONDITIONS	T <sub>A</sub>	MIN	TYP (Note 2)	MAX	UNITS
NC_Off-Capacitance (Force)	C <sub>OFF</sub>	V <sub>COM_</sub> , V <sub>NO_</sub> = GND; f = 1MHz; Figure 14	+25°C		22		pF
NC_Off-Capacitance (Sense-Guard)	C <sub>OFF</sub>	V <sub>COM_</sub> , V <sub>NO_</sub> = GND; f = 1MHz; Figure 14	+25°C		9		pF
Total Harmonic Distortion (Force)	THD		+25°C		0.007		%
Off Isolation (Force) (Note 6)	V <sub>ISO</sub>	R <sub>IN</sub> = 50Ω, R <sub>OUT</sub> = 50Ω, f = 1MHz, V <sub>COM_</sub> = 100mV <sub>RMS</sub> , Figure 15	+25°C		-38		dB
<b>POWER SUPPLY</b>							
Power-Supply Range	V <sub>+</sub> , V <sub>L</sub> , V <sub>-</sub>		C, E	±4.5		±20	V
V <sub>+</sub> Supply Current	I <sub>+</sub>	V <sub>+</sub> = 16.5V; V <sub>-</sub> = -16.5V; V <sub>EN</sub> , V <sub>IN_</sub> = 0 or V <sub>+</sub>	+25°C	-1.0	0.001	1.0	μA
			C, E	-5.0		5.0	
V <sub>-</sub> Supply Current	I <sub>-</sub>	V <sub>+</sub> = 16.5V; V <sub>-</sub> = -16.5V; V <sub>EN</sub> , V <sub>IN_</sub> = 0 or V <sub>+</sub>	+25°C	-1.0	0.001	1.0	μA
			C, E	-5.0		5.0	
V <sub>L</sub> Supply Current	I <sub>L+</sub>	V <sub>+</sub> = 16.5V; V <sub>-</sub> = -16.5V; V <sub>EN</sub> , V <sub>IN_</sub> = 0 or V <sub>+</sub>	+25°C	-1.0	0.001	1.0	μA
			C, E	-5.0		5.0	
Ground Current	I <sub>GND</sub>	V <sub>+</sub> = 16.5V; V <sub>-</sub> = -16.5V; V <sub>EN</sub> , V <sub>IN_</sub> = 0 or V <sub>+</sub>	+25°C	-1.0	0.001	1.0	μA
			C, E	-5.0		5.0	

## ELECTRICAL CHARACTERISTICS—MAX4556 (±15V Supplies)

(V<sub>+</sub> = +15V, V<sub>-</sub> = -15V, V<sub>L</sub> = 5V, GND = 0V, V<sub>IN\_H</sub> = 2.4V, V<sub>IN\_L</sub> = 0.8V, T<sub>A</sub> = T<sub>MIN</sub> to T<sub>MAX</sub>, unless otherwise noted. Typical values are at T<sub>A</sub> = +25°C.)

PARAMETER	SYMBOL	CONDITIONS	T <sub>A</sub>	MIN	TYP (Note 2)	MAX	UNITS
<b>6Ω ANALOG SWITCH (FORCE)</b>							
Analog Signal Range	V <sub>COM1</sub> , V <sub>NO1</sub> , V <sub>NC1</sub>	(Note 3)	C, E	V <sub>-</sub>		V <sub>+</sub>	V
On-Resistance	R <sub>ON</sub>	V <sub>COM1</sub> = ±10V, I <sub>COM1</sub> = 10mA	+25°C		3.8	6	Ω
			C, E			7	
On-Resistance Match (Note 4)	ΔR <sub>ON</sub>	V <sub>COM1</sub> = ±10V, I <sub>COM1</sub> = 10mA	+25°C		0.3	1	Ω
			C, E			1.5	
On-Resistance Flatness (Note 5)	R <sub>FLAT(ON)</sub>	V <sub>COM1</sub> = +5V, 0V, -5V; I <sub>COM1</sub> = 10mA	+25°C		0.05	1	Ω
			C, E			1.5	
NO1, NC1 Off-Leakage Current	I <sub>NO1(OFF)</sub> , I <sub>NC1(OFF)</sub>	V <sub>+</sub> = 16.5V; V <sub>-</sub> = -16.5V; V <sub>COM1</sub> = ±10V; V <sub>NO1</sub> , V <sub>NC1</sub> = ∓10V	+25°C	-0.25	0.03	0.25	nA
			C, E	-2.5		2.5	
COM1 Off-Leakage Current	I <sub>COM1(OFF)</sub>	V <sub>+</sub> = 16.5V, V <sub>-</sub> = -16.5V, V <sub>COM1</sub> = ±10V, V <sub>NO1</sub> = ∓10V	+25°C	-0.5	0.03	0.5	nA
			C, E	-5.0		5.0	
COM1 On-Leakage Current	I <sub>COM1(ON)</sub>	V <sub>+</sub> = 16.5V, V <sub>-</sub> = -16.5V, V <sub>COM1</sub> = ±10V	+25°C	-0.5	0.06	0.5	nA
			C, E	-10		10	
Charge Injection	Q	V <sub>COM1</sub> = 0, Figure 13	+25°C		100		pC



# Force-Sense Switches

MAX4554/MAX4555/MAX4556

## ELECTRICAL CHARACTERISTICS—MAX4556 ( $\pm 15V$ Supplies) (continued)

( $V_+ = +15V$ ,  $V_- = -15V$ ,  $V_L = 5V$ ,  $GND = 0V$ ,  $V_{IN\_H} = 2.4V$ ,  $V_{IN\_L} = 0.8V$ ,  $T_A = T_{MIN}$  to  $T_{MAX}$ , unless otherwise noted. Typical values are at  $T_A = +25^\circ C$ .)

PARAMETER	SYMBOL	CONDITIONS	$T_A$	MIN	TYP (Note 2)	MAX	UNITS
<b>60<math>\Omega</math> ANALOG SWITCH (SENSE-GUARD)</b>							
Analog Signal Range	$V_{COM\_}$ , $V_{NO\_}$ , $V_{NC\_}$	(Note 3)	C, E	V-		V+	V
On-Resistance	$R_{ON}$	$V_{COM\_} = \pm 10V$ , $I_{COM\_} = 10mA$	+25 $^\circ C$ C, E		36 70	60	$\Omega$
On-Resistance Match (Note 4)	$\Delta R_{ON}$	$V_{COM\_} = \pm 10V$ , $I_{COM\_} = 10mA$	+25 $^\circ C$ C, E		5 10	9	$\Omega$
On-Resistance Flatness (Note 5)	$R_{FLAT(ON)}$	$V_{COM\_} = +5V, 0V, -5V$ ; $I_{COM\_} = 10mA$	+25 $^\circ C$ C, E		0.6 6	5	$\Omega$
NO $_1$ , NC $_1$ Off-Leakage Current	$I_{NO\_ (OFF)}$ , $I_{NC\_ (OFF)}$	$V_+ = 16.5V$ ; $V_- = -16.5V$ ; $V_{COM\_} = \pm 10V$ ; $V_{NO\_}$ , $V_{NC\_} = \mp 10V$	+25 $^\circ C$ C, E	-0.25 -2.5	0.01	0.25 2.5	nA
COM $_1$ Off-Leakage Current	$I_{COM\_ (OFF)}$	$V_+ = 16.5V$ ; $V_- = -16.5V$ ; $V_{COM\_} = \pm 10V$ ; $V_{NO\_}$ , $V_{NC\_} = \mp 10V$	+25 $^\circ C$ C, E	-0.25 -2.5	0.01	0.25 2.5	nA
COM $_1$ On-Leakage Current	$I_{COM\_ (ON)}$	$V_+ = 16.5V$ , $V_- = -16.5V$ , $V_{COM\_} = \pm 10V$	+25 $^\circ C$ C, E	-0.5 -5.0	0.02	0.5 5.0	nA
Charge Injection	Q	$V_{COM\_} = 0$ , Figure 13	+25 $^\circ C$		5		pC
<b>LOGIC INPUT</b>							
IN $_1$ Input Logic Threshold High	$V_{IN\_H}$		C, E		1.6	2.4	V
IN $_1$ Input Logic Threshold Low	$V_{IN\_L}$		C, E	0.8	1.6		V
IN $_1$ Input Current Logic High or Low	$I_{IN\_H}$ , $I_{IN\_L}$	$V_{IN\_} = 0$ or $V_L$	C, E	-0.5	0.03	0.5	$\mu A$
<b>SWITCH DYNAMIC CHARACTERISTICS</b>							
Transition Time (Force)	$t_{TRANS}$	$V_{COM\_} = \pm 10V$ , $R_L = 300\Omega$ , Figure 10	+25 $^\circ C$ C, E		150 300	250	ns
Transition Time (Sense-Guard)	$t_{TRANS}$	$V_{COM\_} = \pm 10V$ , $R_L = 1k\Omega$ , Figure 10	+25 $^\circ C$ C, E		125 275	225	ns
Break-Before-Make Time	$t_{BBM}$	$V_{COM\_} = \pm 10V$ , $R_L = 1k\Omega$ , Figure 12	+25 $^\circ C$	1	15		ns
NO $_1$ , NC $_1$ Off-Capacitance (Force)	$C_{OFF}$	$V_{NO1}$ , $V_{NC1} = GND$ ; $f = 1MHz$ ; Figure 14	+25 $^\circ C$		21		pF
COM $_1$ On-Capacitance (Force)	$C_{ON}$	$V_{COM1} = GND$ , $f = 1MHz$ , Figure 14	+25 $^\circ C$		137		pF
NO $_1$ , NC $_1$ Off-Capacitance (Sense-Guard)	$C_{OFF}$	$V_{NO\_}$ , $V_{NC\_} = GND$ ; $f = 1MHz$ ; Figure 14	+25 $^\circ C$		7		pF
COM $_1$ On-Capacitance (Sense-Guard)	$C_{ON}$	$V_{COM\_} = GND$ , $f = 1MHz$ , Figure 14	+25 $^\circ C$		30		pF
Total Harmonic Distortion (Force)	THD		+25 $^\circ C$		0.007		%
Off Isolation (Force)	$V_{ISO}$	$R_{IN} = 50\Omega$ , $R_{OUT} = 50\Omega$ , $f = 1MHz$ , $V_{COM\_} = 100mV_{RMS}$ , Figure 15	+25 $^\circ C$		-30		dB

## Force-Sense Switches

### ELECTRICAL CHARACTERISTICS—MAX4556 ( $\pm 15V$ Supplies) (continued)

( $V_+ = +15V$ ,  $V_- = -15V$ ,  $V_L = 5V$ ,  $GND = 0V$ ,  $V_{IN\_H} = 2.4V$ ,  $V_{IN\_L} = 0.8V$ ,  $T_A = T_{MIN}$  to  $T_{MAX}$ , unless otherwise noted. Typical values are at  $T_A = +25^\circ C$ .)

PARAMETER	SYMBOL	CONDITIONS	$T_A$	MIN	TYP (Note 2)	MAX	UNITS
<b>POWER SUPPLY</b>							
Power-Supply Range	$V_+$ , $V_L$ , $V_-$	$V_L \geq 4.5V$	C, E	$\pm 4.5$		$\pm 20$	V
$V_+$ Supply Current	$I_+$	$V_+ = 16.5V$ , $V_- = -16.5V$ , $V_{IN\_} = 0$ or $V_L$	+25°C	-1.0	0.001	1.0	$\mu A$
			C, E	-5.0		5.0	
$V_-$ Supply Current	$I_-$	$V_+ = 16.5V$ , $V_- = -16.5V$ , $V_{IN\_} = 0$ or $V_L$	+25°C	-1.0	0.001	1.0	$\mu A$
			C, E	-5.0		5.0	
$V_L$ Supply Current	$I_{L+}$	$V_+ = 16.5V$ , $V_- = -16.5V$ , $V_{IN\_} = 0$ or $V_L$	+25°C	-1.0	0.001	1.0	$\mu A$
			C, E	-5.0		5.0	
Ground Current	$I_{GND}$	$V_+ = 16.5V$ , $V_- = -16.5V$ , $V_{IN\_} = 0$ or $V_L$	+25°C	-1.0	0.001	1.0	$\mu A$
			C, E	-5.0		5.0	

**Note 2:** The algebraic convention is used in this data sheet; the most negative value is shown in the minimum column.

**Note 3:** Guaranteed by design.

**Note 4:**  $\Delta R_{ON} = \Delta R_{ON(MAX)} - \Delta R_{ON(MIN)}$ .

**Note 5:** Resistance flatness is defined as the difference between the maximum and the minimum value of on-resistance as measured over the specified analog signal range.

# Force-Sense Switches

## Typical Operating Characteristics

( $V_+ = +15V$ ,  $V_- = -15V$ ,  $GND = 0V$ ,  $T_A = +25^\circ C$ , unless otherwise noted.)

MAX4554/MAX4555/MAX4556

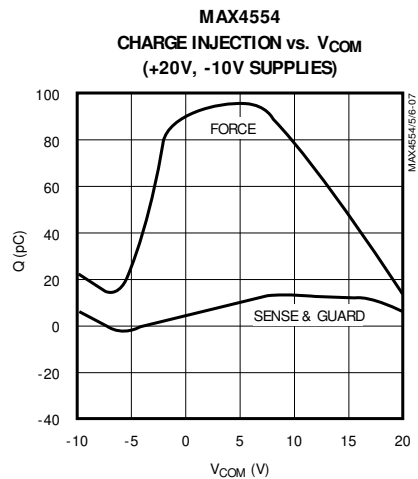
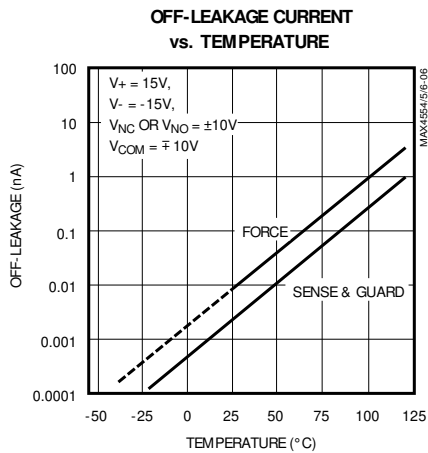
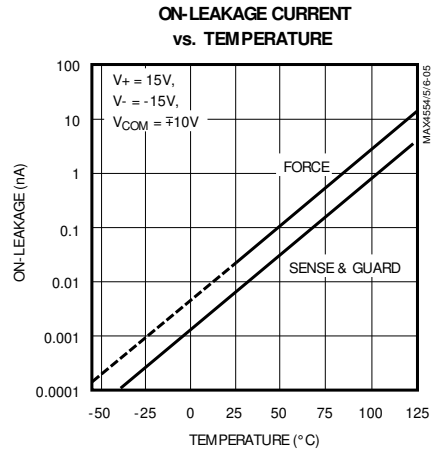
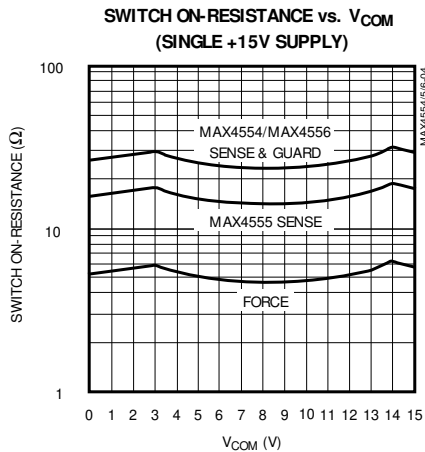
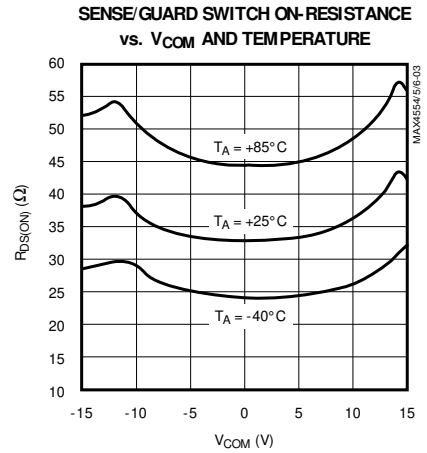
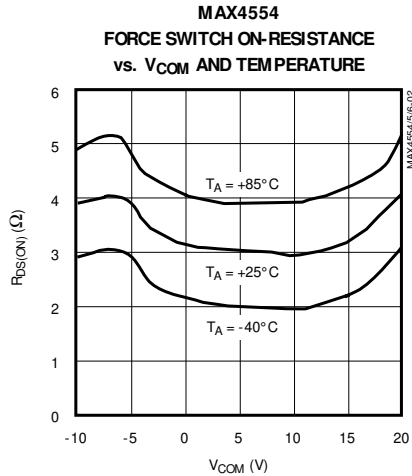
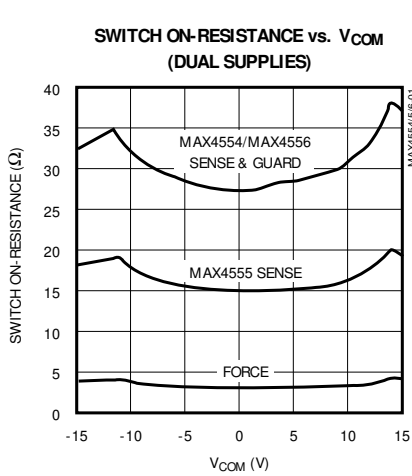

# Force-Sense Switches

## Typical Operating Characteristics (continued)

( $V_+ = +15V$ ,  $V_- = -15V$ , GND = 0V,  $T_A = +25^\circ C$ , unless otherwise noted.)

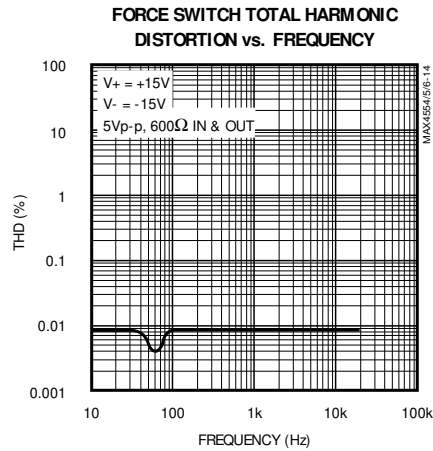
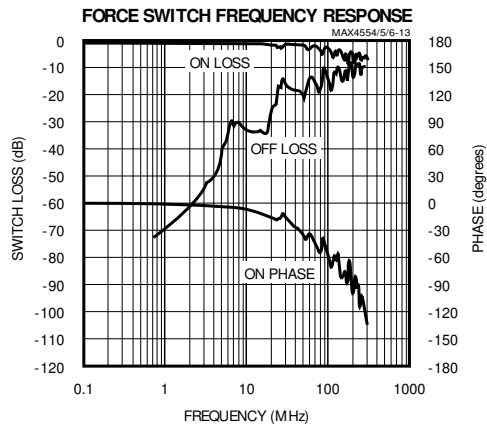
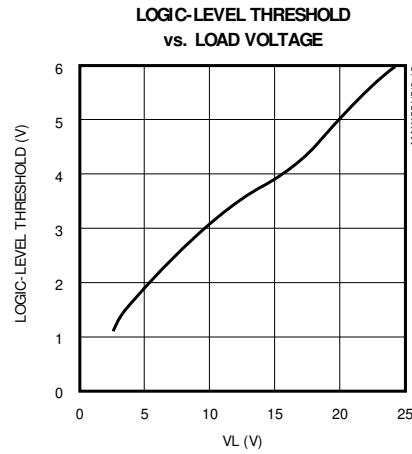
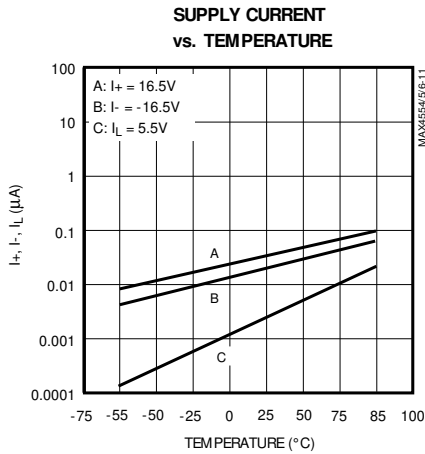
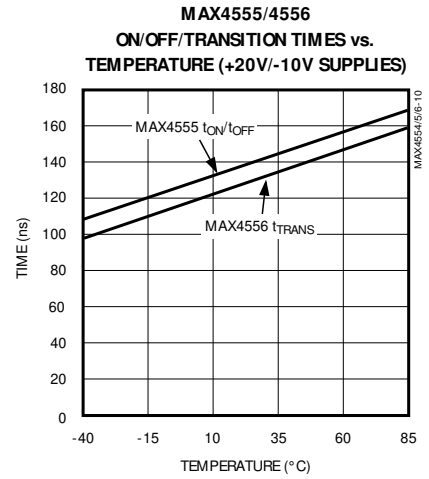
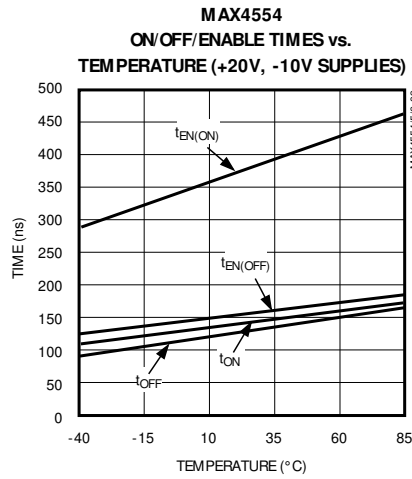
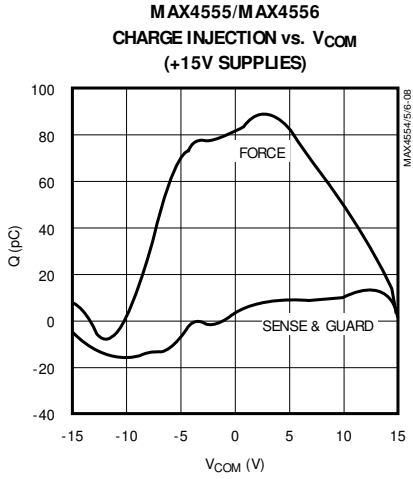

# Force-Sense Switches

## Pin Description

MAX4554/MAX4555/MAX4556

PIN			NAME	FUNCTION
MAX4554	MAX4555	MAX4556		
1	—	—	NOG1	Analog Guard Channel 1 Normally Open Terminal
—	—	1, 2	NO3, NO2	Analog Signal Normally Open Terminals
2	—	—	NOS1	Analog Sense Channel 1 Normally Open Terminal
—	2, 15*, 10*, 7	14*, 15, 16	COM1, COM2 COM3, COM4	Analog Signal Common Terminals. COM2 and COM3 are low-resistance (force) switches on the MAX4555. COM1 is a low-resistance (force) switch on the MAX4556.
3*	—	—	NOF1*	Analog Force Channel 1 Normally Open Terminal
—	3, 14, 11, 6	—	NC1, NC2, NC3, NC4	Analog Signal Normally Closed Pins. NC2 and NC3 are low-resistance (force) switches.
—	—	3*	NO1*	Analog Force Signal Normally Open Terminal
4	4	4	V-	Negative Analog Supply Voltage Input. Connect to GND for single-supply operation.
5	5	5	GND	Ground. Connect to digital ground. (Analog signals have no ground reference; they are limited to V+ and V-.)
6*	—	—	NOF2*	Analog Force Channel 2 Normally Open Terminal
—	—	6*	NC1*	Analog Force Signal Normally Closed Terminal
7	—	—	NOS2	Analog Sense Channel 2 Normally Open Terminal
—	—	7, 8	NC2, NC3	Analog Signal Normally Closed Terminal
8	—	—	NOG2	Analog Guard Channel 2 Normally Open Terminal
9	—	—	$\overline{EN}$	Enable Logic-Level Digital Input. Connect to GND to enable all switches.
11, 10	1, 16, 9, 8	9, 10, 11	IN1, IN2, IN3, IN4	Logic-Level Digital Inputs. See <i>Truth Tables</i> .
12	12	12	VL	Logic-Level Positive Supply Input. Connect to logic (+5V) supply. Can be connected to V+ for single-supply operation.
13	13	13	V+	Positive Analog Supply Voltage Input. Internally connected to substrate.
14*	—	—	COMF*	Analog Force Channel Common Terminal
15	—	—	COMS	Analog Sense Channel Common Terminal
16	—	—	COMG	Analog Guard Channel Common Terminal

\* Indicates high-current, low-resistance (force) switch terminal.

**Note:** NO\_, NC\_, and COM\_ pins are identical and interchangeable. Any may be considered as an input or output; signals pass equally well in either direction.

# Force-Sense Switches

## Force-Sense Philosophy

When a precise voltage must be applied to a load that draws appreciable current, the resistance of the conductors connecting the source and the load can degrade the load voltage. The resistance of the conductors forms a voltage divider with the load, so that the load voltage is lower than the source voltage. The greater the distance between the source and the load, and the greater the current or conductor resistance, the greater the degradation. The resulting signal reduction can be overcome and the signal at the load guaranteed by using a 4-wire technique known as Kelvin sensing, or force-sense.

The basic idea behind the force-sense philosophy is to use four wires, forcing a voltage or current through two high-current wires to the load, and measuring (sensing) the voltage with two separate wires that carry very low or negligible current. One of two basic configurations is used, depending on whether or not feedback is employed:

- 1) The sensed voltage can be completely independent of the forced voltage or current, as in the case of a 4-wire ohmmeter, where a constant current is forced through one pair of wires and the voltage at the resistor is measured by another pair.
- 2) The sensed voltage can be part of a feedback circuit to force the load voltage to the desired value, as in the case of a 4-wire power supply. (In rare cases, this method is also used to measure resistance; the source is forced to produce a desired voltage in the resistor, and the source current required to achieve this voltage is measured.)

In all cases, the resistance of the high-current conductors can be ignored and the sensed voltage is an accurate measure of the load (or resistor's) voltage, despite appreciable voltage loss in the wires connecting the source and load.

There are two limitations to this scheme. First, the maximum source voltage (compliance) must be able to overcome the combined voltage loss of the load and the connecting wires. In other words, the conductors in the force circuit can have significant resistance, but there is a limit. Second, the impedance of the sensing circuit (typically a voltmeter, A/D converter, or feedback amplifier) must be very high compared to the load resistance and the sense wire resistance. These limitations are usually simple to overcome. The source compliance is usually required to be only a volt more than the load voltage, and the sense wire usually has a multimegohm impedance. Typical 4-wire force-sense configurations are shown in Figure 1.

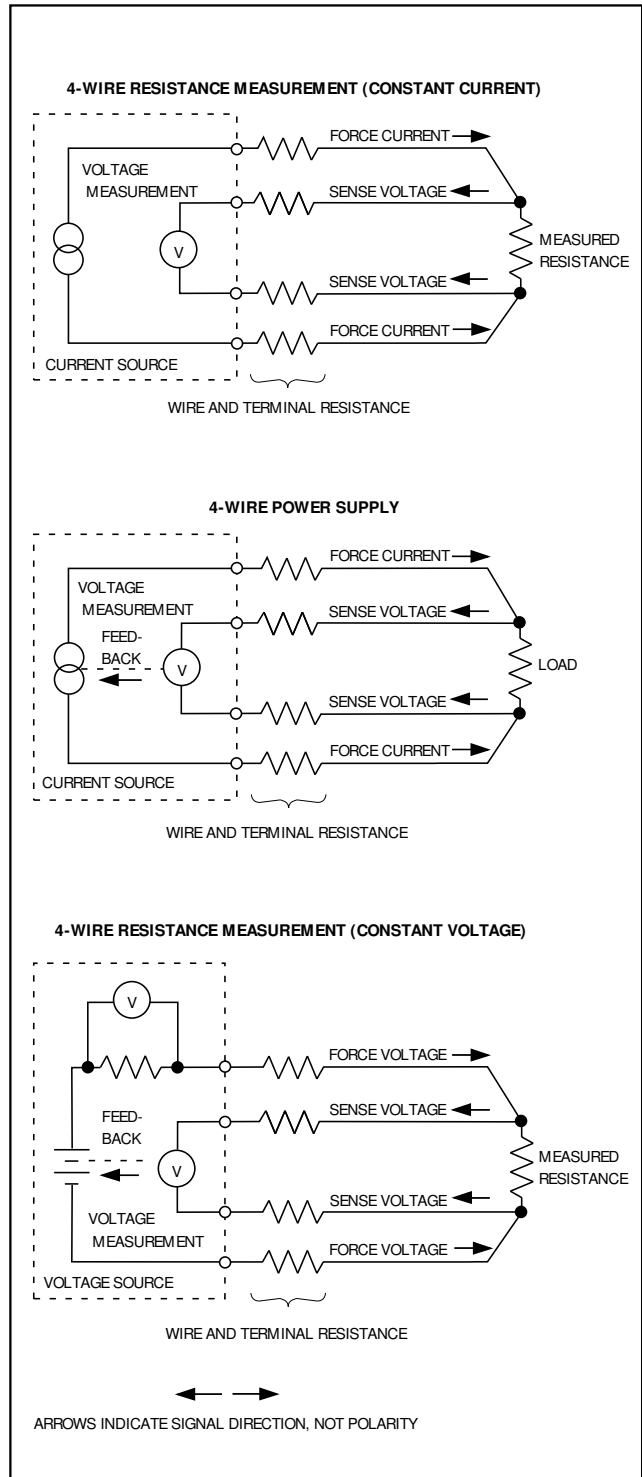

Figure 1. 4-Wire Force-Sense Measurements

## Force-Sense Switches

### Guard Philosophy

When measuring a precise voltage from a high-resistance source, or when measuring a very small current or forcing it into a load, unwanted leakage currents can degrade the results. These leakage currents may exist in the insulation of wires connecting the source and the measuring device. Higher source voltages, higher source impedances, longer wires, lower currents, and higher temperatures further degrade the measurement. The effect has both DC and low-frequency AC components; AC signals are generally capacitively coupled into the high-impedance source and wiring. The AC and DC effects are hard to separate, and are generally grouped under the designation “low-frequency noise.” This signal degradation can be overcome and the measured signal guaranteed by using a 3-wire technique known as guarding.

A “guard,” “guard channel,” or “driven guard” is formed by adding a third wire to a 2-wire measurement. It consists of a physical barrier (generally the surrounding shield of a coaxial cable) that is actively forced to the same voltage as is being measured on its inner conductor. The forcing of the driven guard is from the output of a low-impedance buffer amplifier whose high-impedance input is connected to the source. The idea is not just to buffer or shield the signal with a low-impedance source but, by forcing the shield to the same potential as the signal, to also force the leakage currents between the signal and the outside world to extremely small values. Any unwanted leakage current from the source must first go through the coaxial-cable insulation to the shield. Since the shield is at the same potential, there is virtually no unwanted leakage current, regardless of the insulation resistance. The shield itself can have significant leakage currents to the outside world, but it is separated from the measured signal.

The physical positioning of the guard around the signal is extremely important in maintaining low leakage. Since the guard can be at potentials far from ground, conventional coaxial cable is often replaced by triaxial cable (i.e., cable with a center conductor and two separate inner and outer shields). The signal is the center conductor, the inner shield is the guard, and the outer shield is the chassis ground. The outer shield isolates the inner driven guard from ground, physically protects the driven guard, and acts as a secondary Faraday shield for external noise.

The physical guard must be maintained continuously from the source to the measuring device, including paths on printed circuit boards, where the guard becomes extra traces surrounding the signal traces on both sides (and above and below the signal traces on

multilevel boards.) This is one case where a ground plane is *not* appropriate. In extreme cases, such as with nano-voltmeters and femto-ammeters, printed circuit boards cannot be adequately shielded and are eliminated from the guarded signal paths altogether.

Figure 2 shows both the basic 3-wire guarded measurement and a 5-wire variation, used for balanced signals that are elevated from ground potential. The 5-wire configuration is really two 3-wire circuits sharing a common ground. Figure 2 also shows the configuration using triaxial cable.

### Force-Sense-Guard Philosophy

Force-sense measurements are combined with guarded measurements when a wide range of voltages and currents are encountered, or when voltage and current must be accurately measured or controlled simultaneously. This frequently occurs in automatic test equipment (ATE) and in some critical physical or chemical sensor applications where voltage and/or current measurements can span many decades. Two techniques are used: 8-wire and 12-wire.

#### 8-Wire Measurements

Figure 3 shows an 8-wire guarded force-sense power supply. A precise voltage is forced to the load, and load current is sensed without interacting with the output voltage, and without unwanted leakage currents. Separate twin-axial, or “twinax” cable is used for each of the positive and negative wires. Each cable has a twisted-pair of wires surrounded by a common shield, which is connected as the driven guard. Since the force and sense wires are at approximately the same potential, they can be protected by the same driven guard. In critical applications, two special 4-wire cables and connectors are substituted for the two twinax cables and separate ground wire. These cables add a second shield, which replaces the chassis-to-chassis ground wire and reduces noise.

Figure 3 shows current sensing with a fixed precision resistor and voltmeter, but other methods (such as op amps with feedback) are frequently employed, particularly if current limiting is required. One of the advantages of Figure 3’s circuit is that leakage in the current-sensing path has no effect on the output voltage.

The two diodes in the force-sense feedback path protect the force-sense amplifier from operating open loop if either the force or sense wires are disconnected from the load. These diodes must have both lower forward voltage and lower reverse leakage than the current being measured.

# Force-Sense Switches

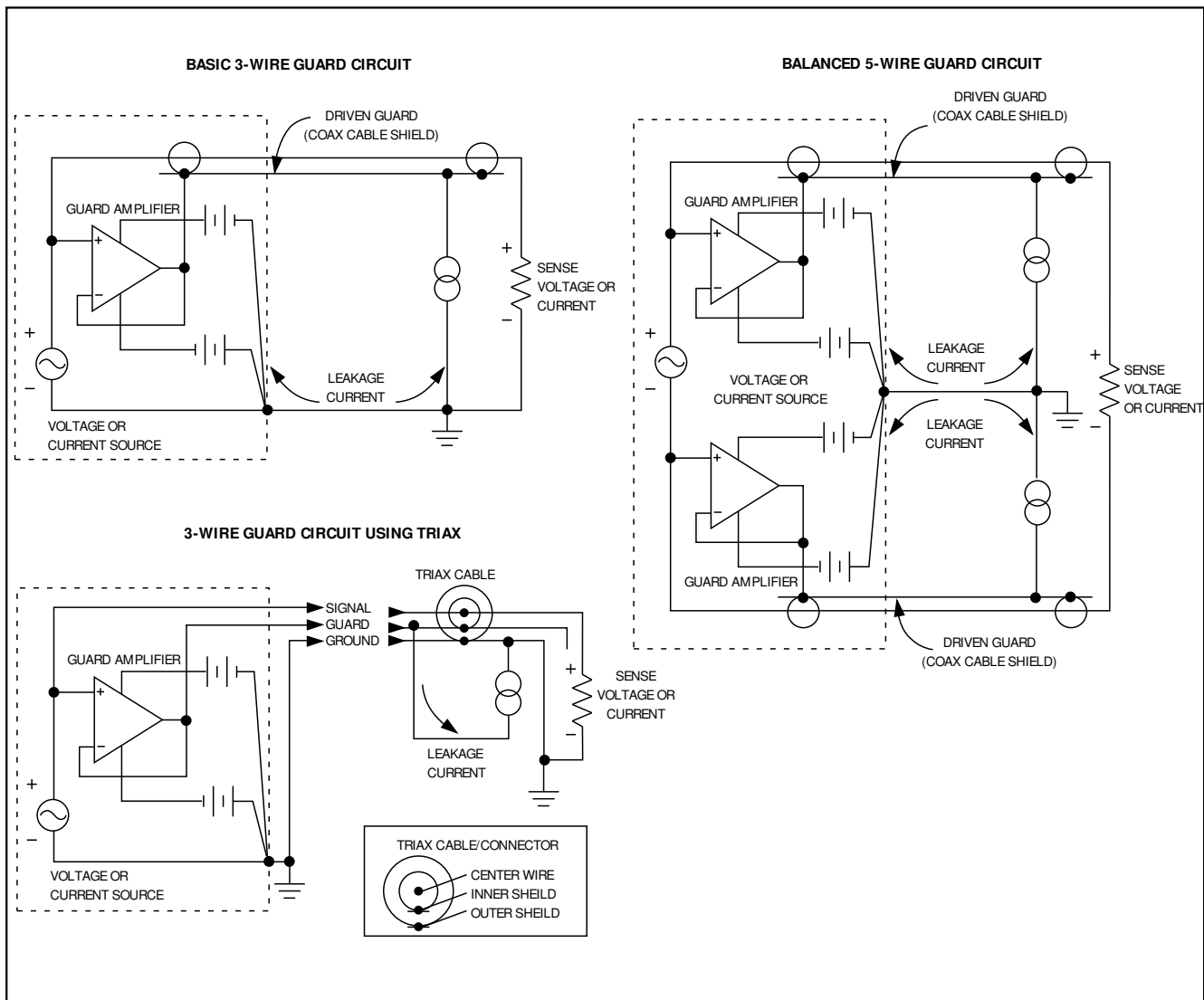

Figure 2. 3-Wire and 5-Wire Guarded Measurements



# Force-Sense Switches

MAX4554/MAX4555/MAX4556

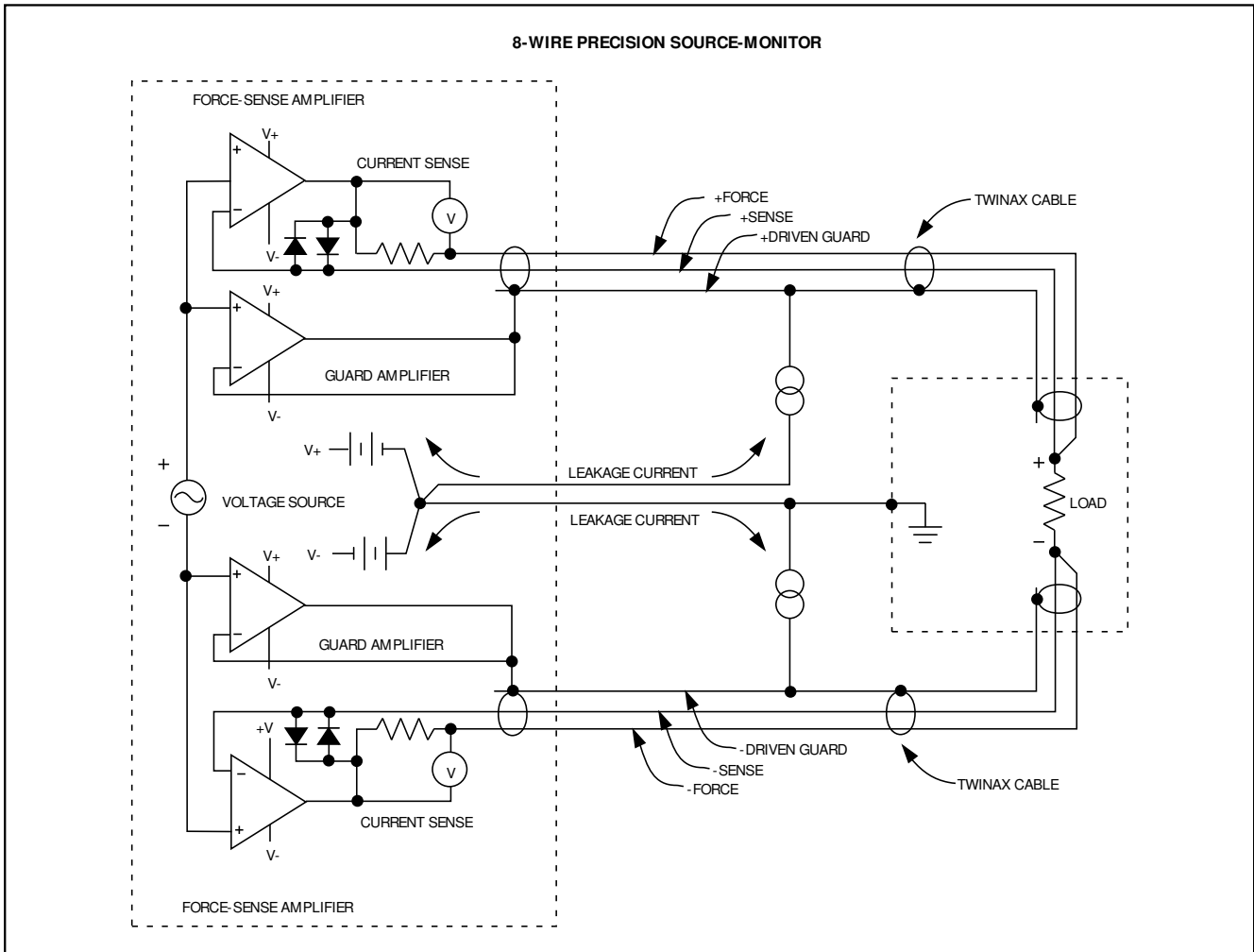

Figure 3. 8-Wire Guarded Force-Sense Measurements

Note that although the positive and negative circuits are identical, they are not redundant. Both are always used, even when one side of the load is grounded, because maintaining a precision output voltage requires losses in the ground leads to be corrected by a force-sense amplifier. If more than one power supply and load are operated together, and they have a common connection, this requirement becomes even more critical. Separate 8-wire connections prevent current changes in one load from changing voltage in the other load.

## 12-Wire Measurements

Figure 4 shows a 12-wire circuit, which is an elaboration of the 8-wire system using separate driven guards for the force and sense wires. Four sets of triaxial

cables and connectors are used. The extra wires are used for two reasons: 1) They provide better shielding by having separate chassis grounds on each cable, rather than separate ground wires external to the signal cables; 2) In test equipment, where connection changes are frequent, it is very convenient to use four triax connectors or two quadax (dual triax) connectors for each load.

In addition, this method is slightly better for power supplies or measurements that switch between constant voltage and constant current, since separate driven guards reduce circuit capacitance. Also, when troubleshooting, it is convenient to be able to interchange force and sense leads.



## Force-Sense Switches

### Switching Guarded and Force-Sense Signals

When a precision source or measurement must be connected sequentially to several circuits, all sense and guard connections must be switched simultaneously, and at least one of the force connections must be switched. To maintain safety and low noise levels, the ground (or chassis) connection should never be disconnected.

The force circuit switch should have low-resistance, high-current capability, but the sense and guard circuit switches require only moderate resistance and current capability. The sense and guard switches should have lower leakage than the lowest measured current. CMOS switches should also be operated from power supplies higher than the highest circuit voltage to be switched.

### Detailed Description

The MAX4554/MAX4555/MAX4556 are CMOS analog ICs configured as force-sense switches. Each part contains low-resistance switches for forcing current, and higher resistance switches for sensing a voltage or driving guard wires. Analog signals on the force, sense, or guard circuits can range from  $V_-$  to  $V_+$ . Each switch is completely symmetrical and signals are bidirectional; any switch terminal can be an input or output. The switches' open or closed states are controlled by TTL/CMOS-compatible input ( $IN_*$ ) pins.

The MAX4555 and MAX4556 are characterized and guaranteed only with  $\pm 15V$  supplies, but they can operate from a single supply up to  $+44V$  or non-symmetrical supplies with a voltage totaling less than  $+44V$ . The MAX4554 is fully characterized for operation from  $\pm 15V$  supplies, and it is also fully specified for operation with  $+20V$  and  $-10V$  supplies. A separate logic supply pin,  $VL$ , allows operation with  $+5V$  or  $+3V$  logic, even with unusual  $V_+$  values. The negative supply pin,  $V_-$ , must be connected to GND for single-supply operation.

The MAX4554 contains two force switches, two sense switches, and two guard switches configured as two 3PST switches. The two switches operate independently of one another, but they have a common connection, allowing one source to be connected simultaneously to two loads, or two sources to be connected to one load. An enable pin,  $\overline{EN}$ , turns all switches off when driven to logic high. The MAX4554 is also fully specified for operation with  $+20V$  and  $-10V$  supplies. The MAX4555 contains four independent SPDT, NC switches; two are force switches and two are sense switches. The MAX4556 contains three independent SPDT switches; one is a force switch and two are sense switches.

### Switch Resistances

Each IC contains four internal switches: four low-current sense-guard switches and two high-current force switches. Each sense-guard switch has an on-resistance of approximately  $60\Omega$ , while each force switch has an on-resistance of approximately  $6\Omega$ . The MAX4555's two low-current sense-guard switches are connected in parallel to produce lower on-resistance and allow higher current.

### Power-Supply Considerations

#### Overview

The MAX4554/MAX4555/MAX4556's construction is typical of most CMOS analog switches. They have four supply pins:  $V_+$ ,  $V_-$ ,  $VL$ , and GND.  $V_+$  and  $V_-$  are used to drive the internal CMOS switches and set the analog voltage limits on any switch. Reverse ESD protection diodes are internally connected between each analog and digital signal pin and both  $V_+$  and  $V_-$ . If any signal exceeds  $V_+$  or  $V_-$ , one of these diodes will conduct. During normal operation these reverse-biased ESD diodes leak, forming the only current drawn from the signal paths.

Virtually all the analog leakage current comes through the ESD diodes to  $V_+$  or  $V_-$ . Although the ESD diodes on a given signal pin are identical, and therefore fairly well balanced, they are reverse biased differently. Each is biased by either  $V_+$  or  $V_-$  and the analog signal. This means their leakages vary as the signal varies. The *difference* in the two diode leakages from the signal path to the  $V_+$  and  $V_-$  pins constitutes the analog-signal-path leakage current. All analog leakage current flows to the supply terminals, not to the other switch terminal. This explains how both sides of a given switch can show leakage currents of either the same or opposite polarity.

There is no connection between the analog signal paths and GND or  $VL$ . The analog signal paths consist of an N-channel and P-channel MOSFET with their sources and drains paralleled, and their gates driven out of phase to  $V_+$  and  $V_-$  by the logic-level translators.

$VL$  and GND power the internal logic and logic-level translator and set the input logic threshold. The logic-level translator converts the logic levels to switched  $V_+$  and  $V_-$  signals for driving the gates of the analog switches. This drive signal is the only connection between GND and the analog supplies.  $V_+$  and  $V_-$  have ESD-protection diodes to GND. The logic-level inputs ( $IN_*$  and  $\overline{EN}$ ) have ESD protection to  $V_+$  and  $V_-$ , but not to GND; therefore, the logic signal can go below GND (as low as  $V_-$ ) when bipolar supplies are used. The logic-level threshold  $V_{IN}$  is CMOS and TTL compatible when  $VL$  is between  $4.5V$  and  $36V$  (see *Typical Operating Characteristics*).

# Force-Sense Switches

Increasing V- has no effect on the logic-level thresholds, but it does increase the drive to the internal P-channel switches, reducing the overall switch on-resistance. V- also sets the negative limit of the analog signal voltage.

### Bipolar-Supply Operation

The MAX4554/MAX4555/MAX4556 operate with bipolar supplies between  $\pm 4.5V$  and  $\pm 18V$ . However, since all factory characterization is done with  $\pm 15V$  supplies (and  $+20V, -10V$  for MAX4554), operation at other supplies is not guaranteed. The V+ and V- supplies need not be symmetrical, but their sum cannot exceed the absolute maximum rating of 44V (see *Absolute Maximum Ratings*). VL must not exceed V+.

### Single-Supply Operation

The MAX4554/MAX4555/MAX4556 operate from a single supply between  $+4.5V$  and  $+44V$  when V- is con-

nected to GND. All of the bipolar precautions must be observed.

## Applications Information

### Switching 4-Wire Force-Sense Circuits

Figure 5 shows how to switch a single voltage or current source between two loads using two MAX4555s. A single CMOS inverter ensures that only one switch is on at a time. On each MAX4555, switches 2 and 3 are the high-current switches, so they should be used for force circuits. By interchanging loads and sources, the circuit can be reversed to switch two sources to a single load. Additional MAX4555s and loads or sources can be added to expand the circuit, but additional IN\_ address decoding must be incorporated.

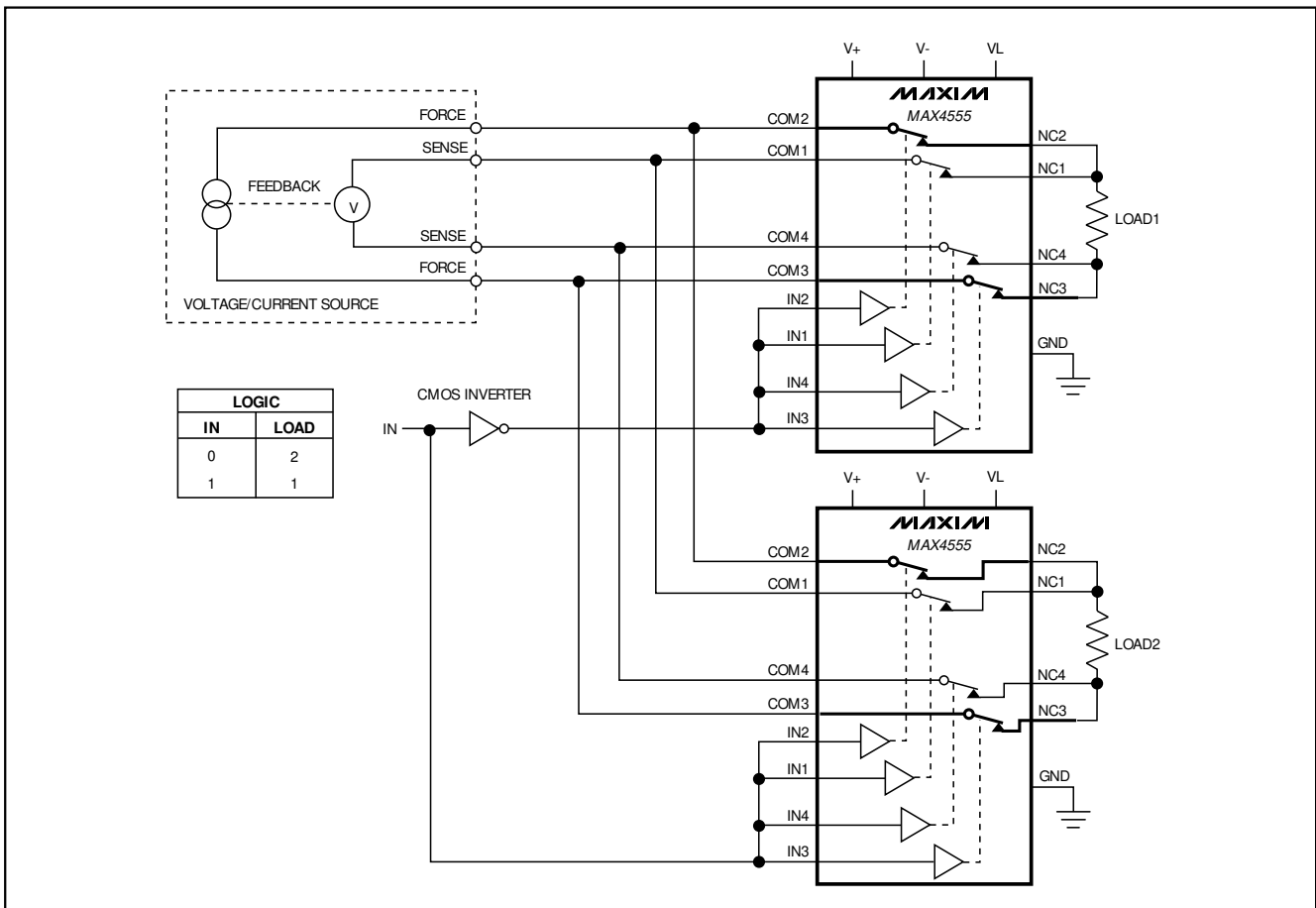

Figure 5. Using the MAX4555 to Switch 4-Wire Force-Sense Circuits from One Source to Two Loads

# Force-Sense Switches

Figure 6 shows how to switch a single voltage or current source between two loads using the MAX4554 or MAX4556. By interchanging loads and sources, the circuits can be reversed so that they switch two sources to a single load. The two loads are electrically connected together at one point, but may be physically separated. This means that one force wire does not need to be switched, but the corresponding sense wires do.

The MAX4554 has independent 3PST, NO switches driven out of phase by an external CMOS inverter, so that one switch is on while the other is off. If both switches were turned on at the same time, both loads would be connected, and the resulting voltage at either load

would be close to (but not exactly equal to) the desired value; this would not cause any damage to the device.

### Switching 3-Wire Guarded Circuits

Figure 7 shows how to switch a single guarded voltage or current source between two loads using the MAX4554 or MAX4556. By interchanging loads and sources, the circuits can be reversed to switch two sources to a single load. If the loads have a common connection, the switch to that node can be eliminated.

Note that these circuits use sense (high-resistance) switches to switch the common wire. This is permissible only if the load currents are very low. If the currents are high, the common connection should not be switched unless another force switch is substituted.

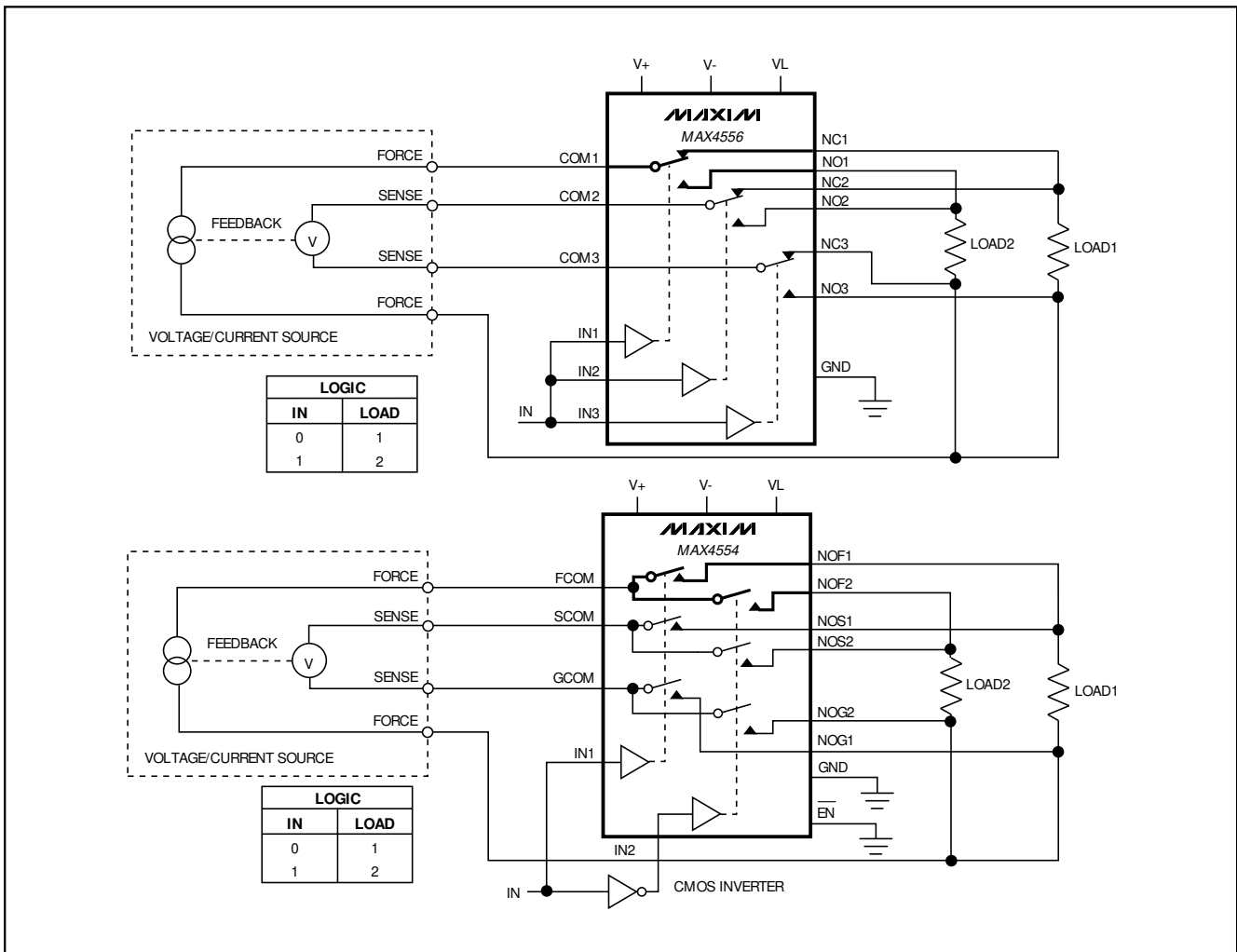

Figure 6. Using the MAX4554/MAX4556 to Switch 4-Wire Force-Sense Circuits from One Source to Two Loads

# Force-Sense Switches

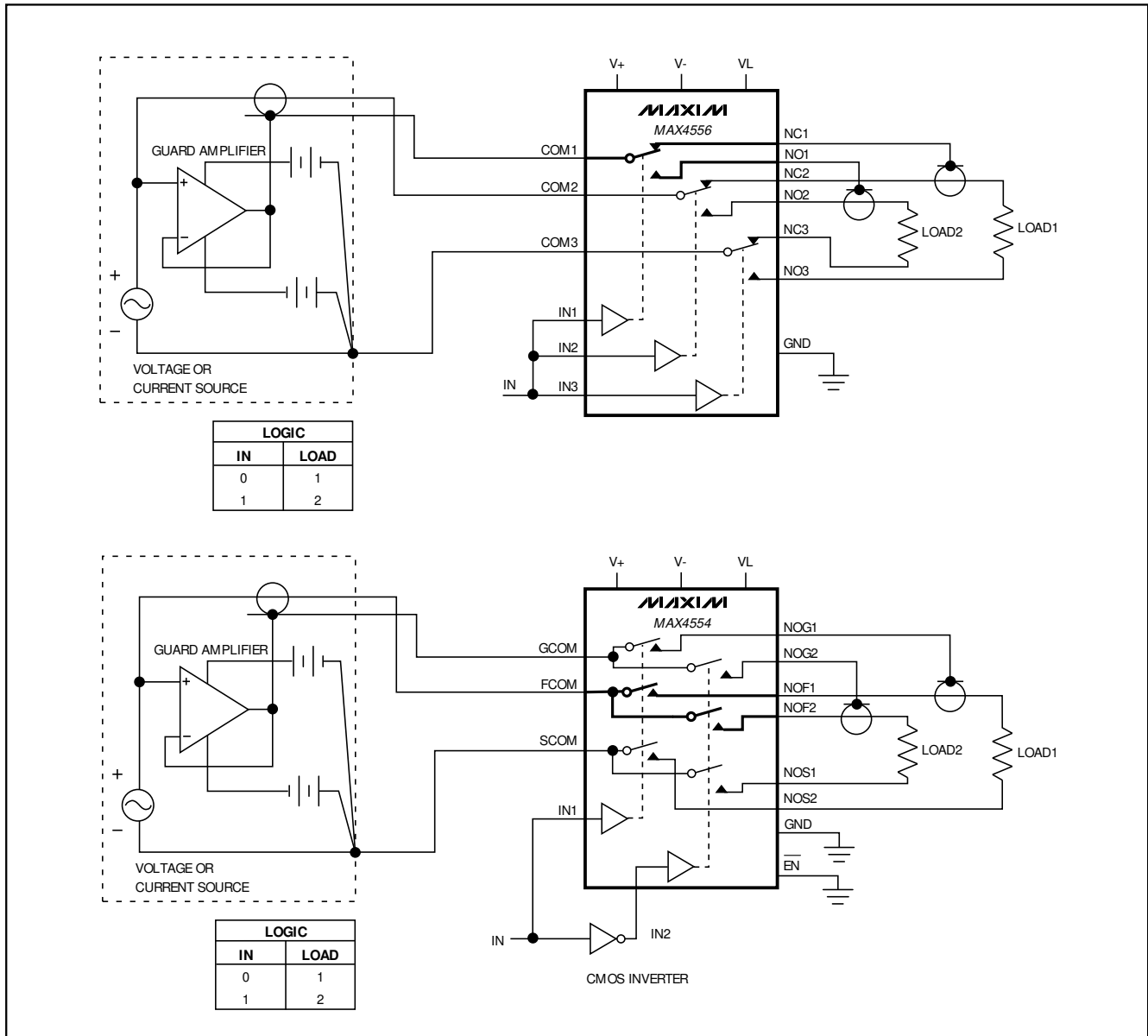

Figure 7. Using the MAX4554/MAX4556 to Switch 3-Wire Guarded Circuits from One Source to Two Loads

## Force-Sense Switches

Figure 8 shows how to switch a single guarded voltage or current source between two grounded loads using a MAX4555. By interchanging loads and sources, the circuits can be reversed so that two sources are switched to a single load.

### Switching 8-Wire Guarded Circuits

Figure 9 shows how to switch a single 8-wire guarded voltage or current source between two loads using two MAX4556s or two MAX4554s. By interchanging loads and sources, the circuits can be reversed so that they switch two sources to a single load. The two loads are shown isolated from each another, but if they have a common connection then the circuit must remain as shown in order to maintain accurate load voltage.

**High-Frequency Performance**  
 Although switching speed is restricted, once a switch is in a steady state it exhibits good RF performance. In 50Ω systems, signal response is reasonably flat up to 50MHz (see *Typical Operating Characteristics*). The force switches have lower on-resistance, so their insertion loss in 50Ω systems is lower. Above 20MHz, the on-response has several minor peaks that are highly layout dependent. The problem with high-frequency operation is not turning the switches on, but turning them off. The off-state switches act like capacitors and pass higher frequencies with less attenuation. At 10MHz, off-isolation between input or output signals is approximately -30dB in 50Ω systems, degrading (approximately 20dB per decade) as frequency increases. Higher circuit impedances also degrade off-isolation.

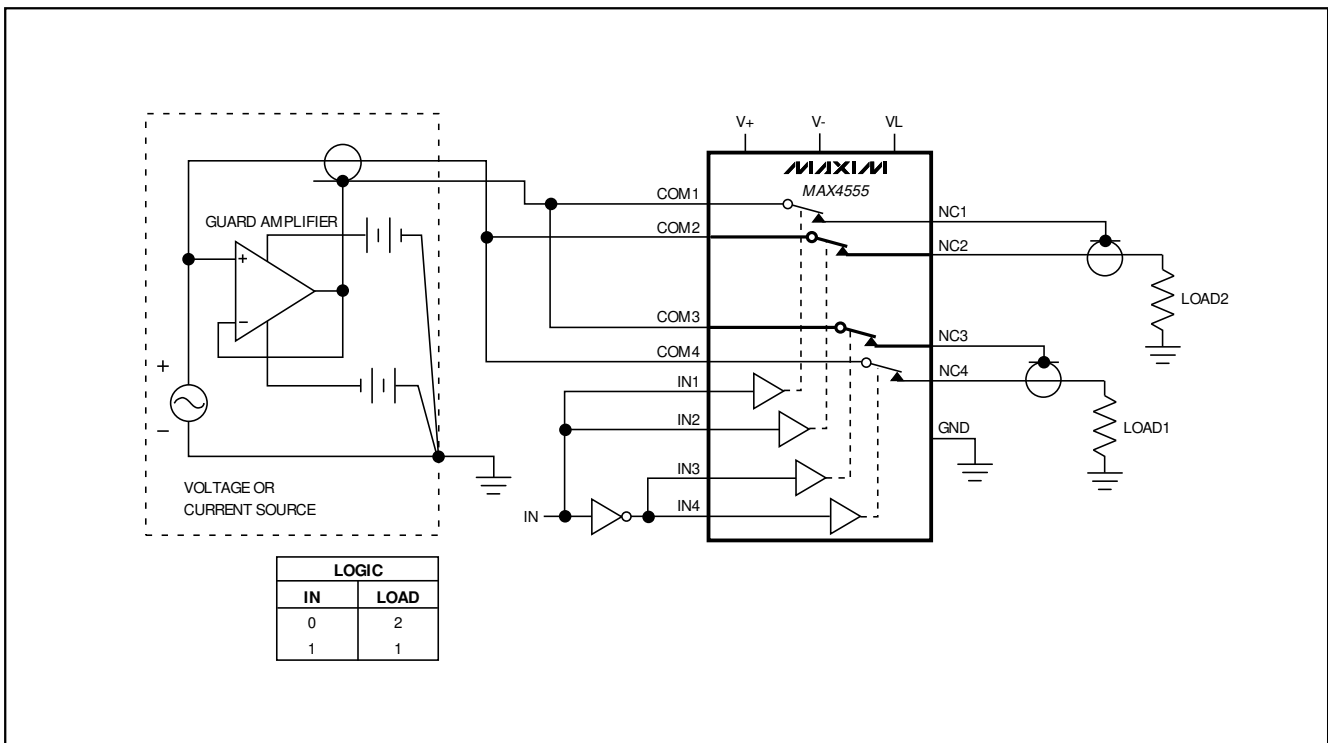

Figure 8. Using the MAX4555 to Switch 3-Wire Guarded Circuits from One Source to Two Loads

# Force-Sense Switches

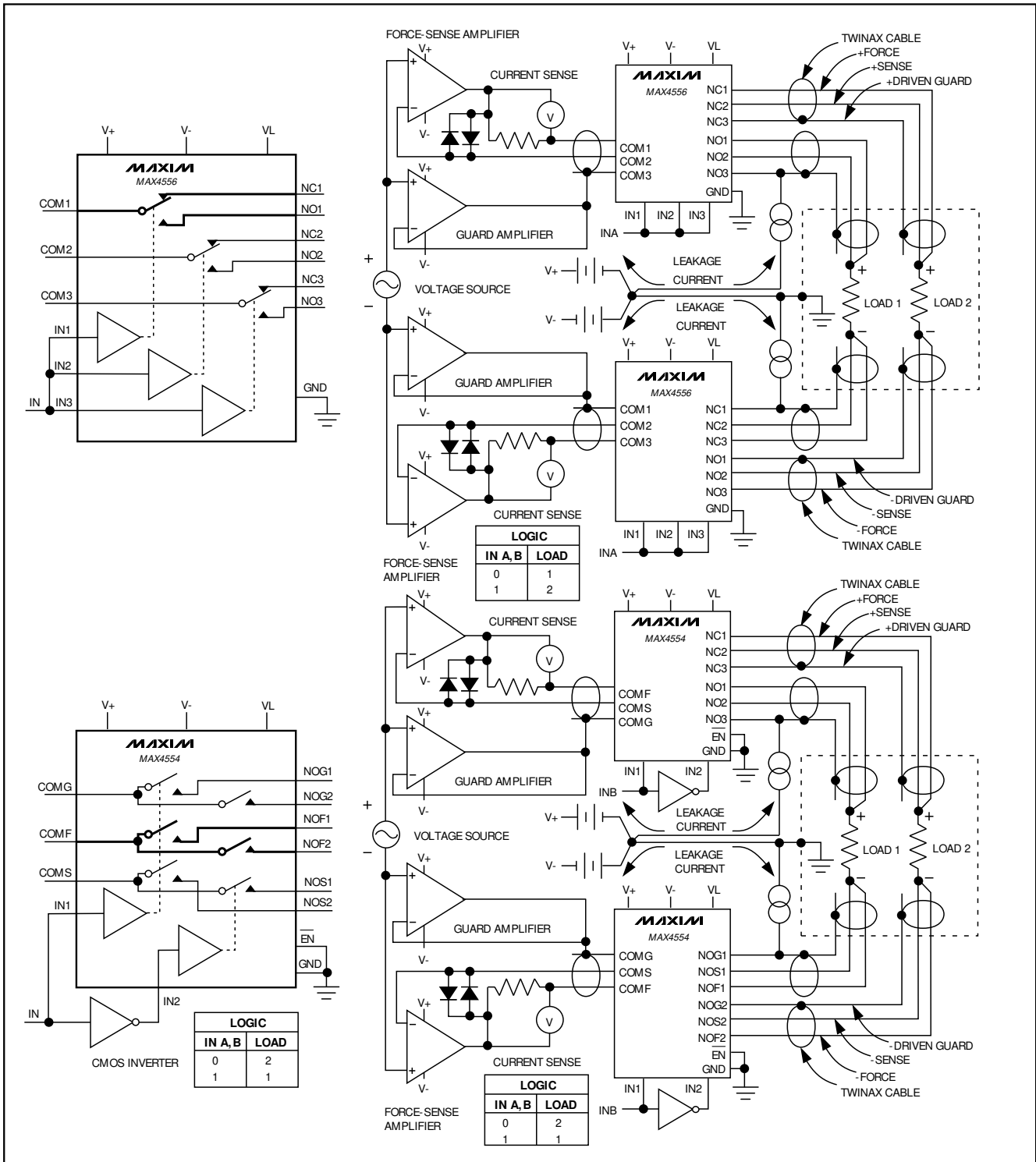

Figure 9. Switching 8-Wire Guarded Force-Sense Measurements from One Precision Source-Monitor to Two Loads



# Force-Sense Switches

## Test Circuits/Timing Diagrams

MAX4554/MAX4555/MAX4556

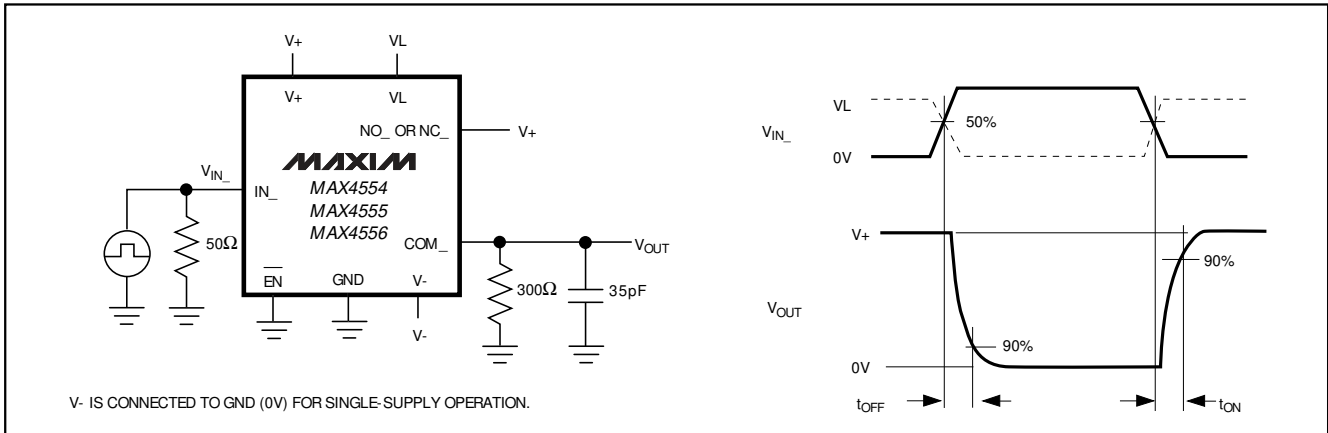

Figure 10. Address Transition Time

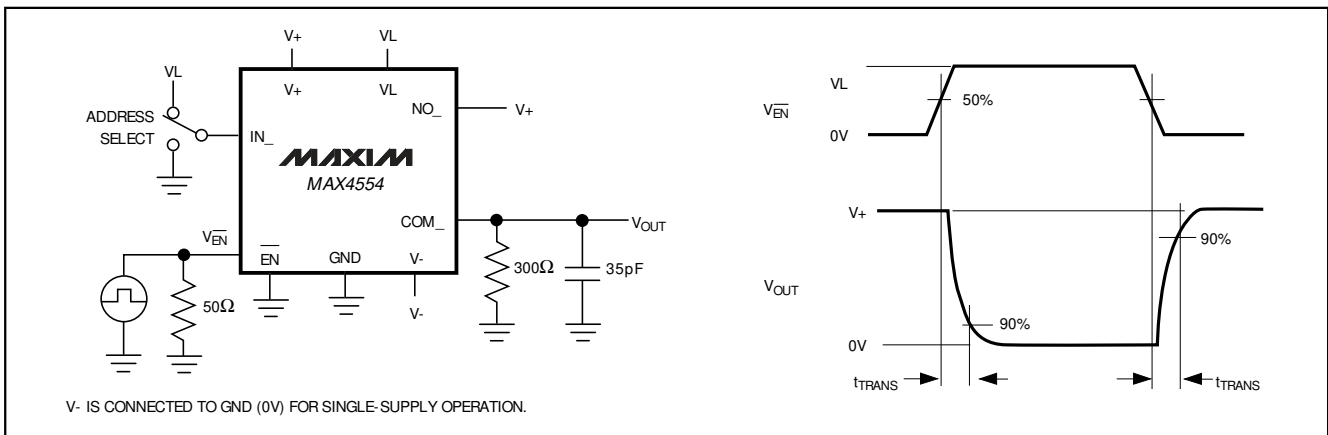

Figure 11. Enable Transition Time

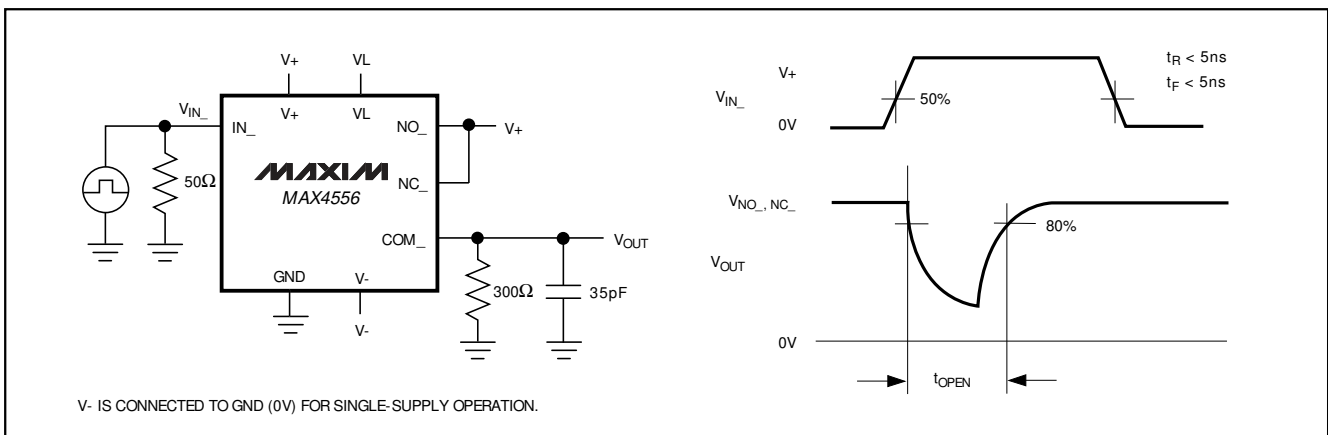

Figure 12. Break-Before-Make Interval

# Force-Sense Switches

## Test Circuits/Timing Diagrams (continued)

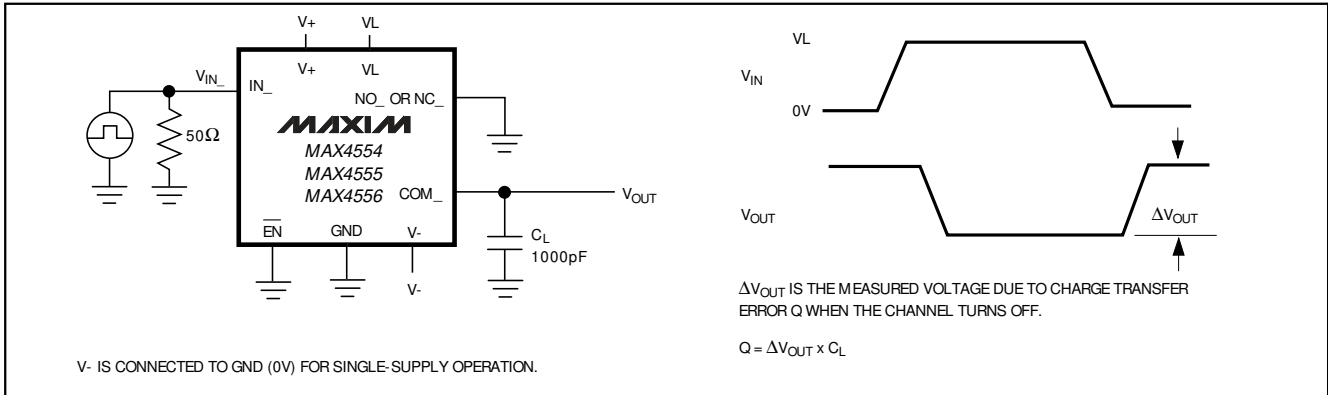

Figure 13. Charge Injection

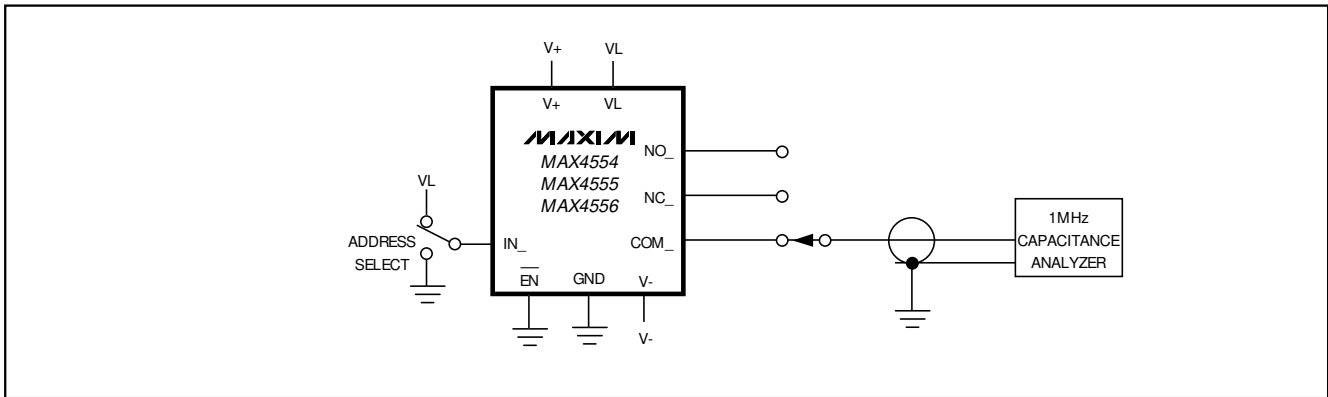

Figure 14. COM, NO, NC Capacitance

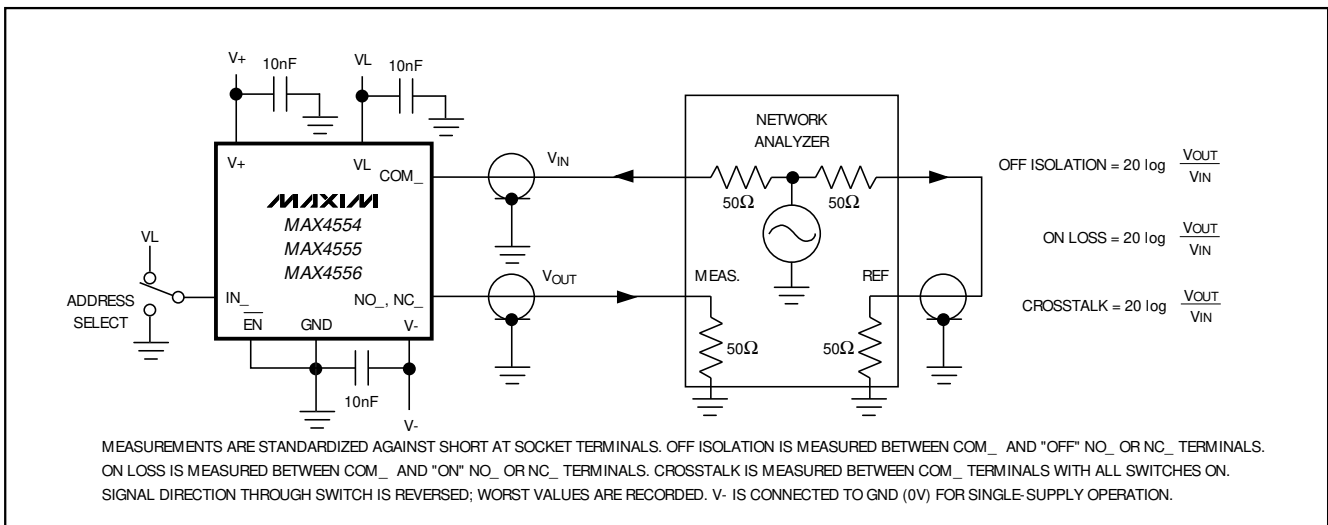
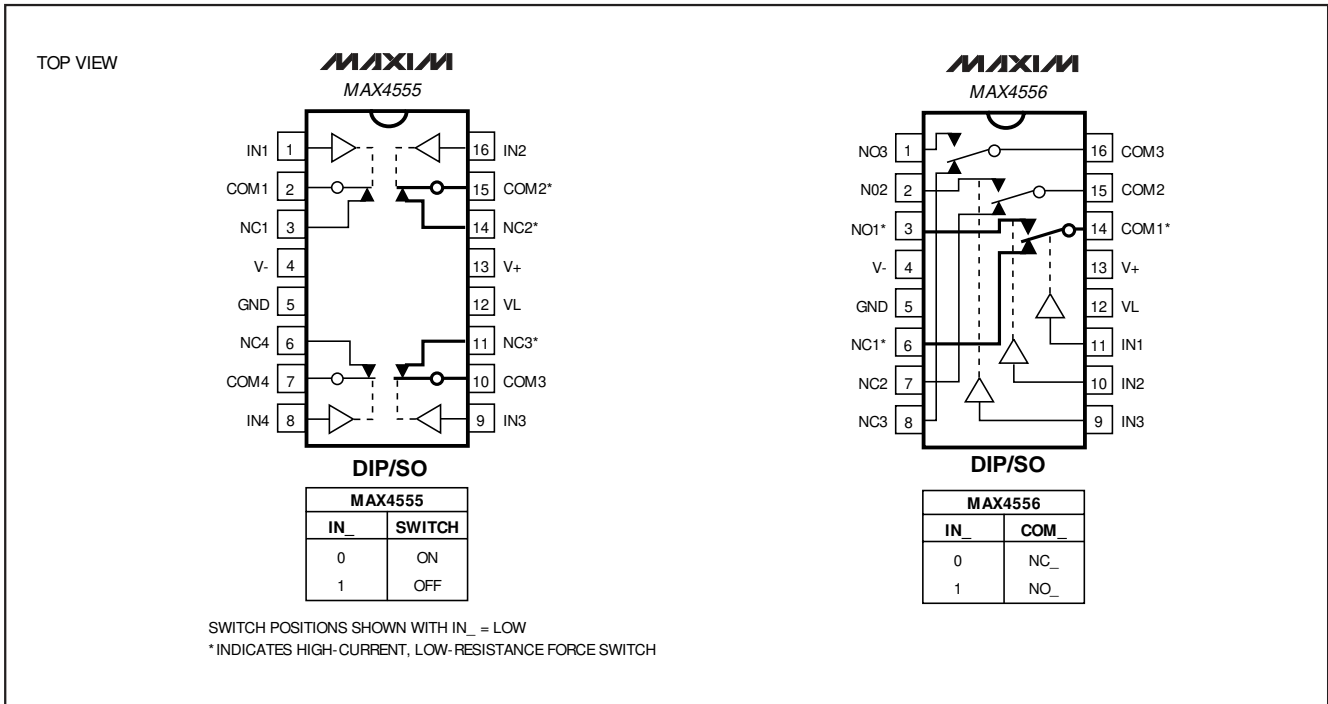

Figure 15. Frequency Response, Off-Isolation, and Crosstalk

# Force-Sense Switches

## Pin Configurations/Functional Diagrams/Truth Tables (continued)

MAX4554/MAX4555/MAX4556



## Ordering Information (continued)

PART	TEMP. RANGE	PIN-PACKAGE
<b>MAX4555</b> CPE	0°C to +70°C	16 Plastic DIP
MAX4555CSE	0°C to +70°C	16 Narrow SO
MAX4555C/D	0°C to +70°C	Dice*
MAX4555EPE	-40°C to +85°C	16 Plastic DIP
MAX4555ESE	-40°C to +85°C	16 Narrow SO
<b>MAX4556</b> CPE	0°C to +70°C	16 Plastic DIP
MAX4556CSE	0°C to +70°C	16 Narrow SO
MAX4556C/D	0°C to +70°C	Dice*
MAX4556EPE	-40°C to +85°C	16 Plastic DIP
MAX4556ESE	-40°C to +85°C	16 Narrow SO

\*Contact factory for availability.

# Force-Sense Switches

## Chip Topographies

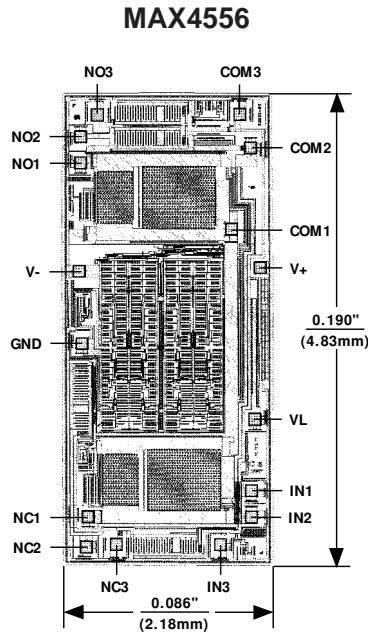
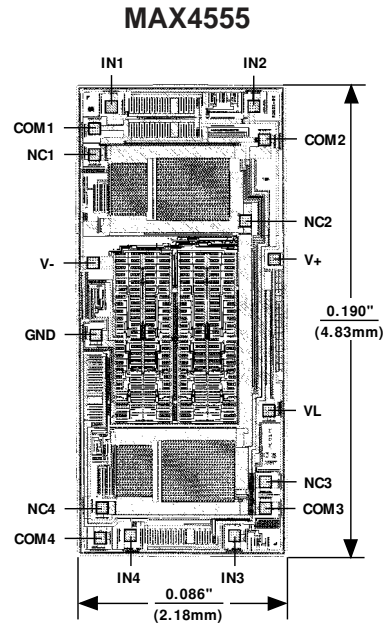
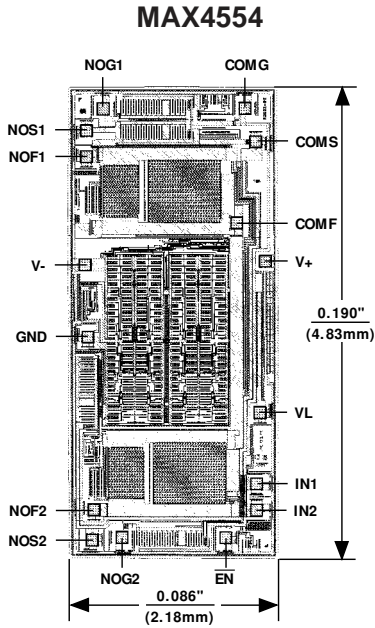

TRANSISTOR COUNT: 197

SUBSTRATE IS INTERNALLY CONNECTED TO V+

Maxim cannot assume responsibility for use of any circuitry other than circuitry entirely embodied in a Maxim product. No circuit patent licenses are implied. Maxim reserves the right to change the circuitry and specifications without notice at any time.

28 Maxim Integrated Products, 120 San Gabriel Drive, Sunnyvale, CA 94086 408-737-7600