

Current Transducer IT 605-S ULTRASTAB

$I_{PN} = 600\text{ A}$

For ultra-high precision measurement of current: DC, AC, pulsed..., with galvanic separation between primary and secondary.



Features

- Wide operating temperature range of $-40\text{ }^{\circ}\text{C}$ to $85\text{ }^{\circ}\text{C}$
- Closed loop (compensated) current transducer using an extremely accurate zero flux detector
- Electrostatic shield between primary and secondary circuit
- 9-pin D-Sub male secondary connector
- Optically insulated output (photocoupler type) indicates transducer state
- LED indicator confirms normal operation.

Advantages

- Very high accuracy
- Excellent linearity
- Extremely low temperature drift
- Wide frequency bandwidth
- High immunity to external fields
- No insertion losses
- Low noise on output signal
- Low noise feedback to primary conductor.

Applications

- Feed back element in high performance gradient amplifiers for MRI
- Feedback element in high-precision, high-stability power supplies
- Calibration unit
- Energy measurement
- Medical equipment.

Standards

- EN 61000-6-2: 2005
- EN 61000-6-3: 2007
- EN 61010-1: 2010.

Application Domains

- Industrial
- Laboratory
- Medical.

Insulation coordination

Parameter	Symbol	Unit	Value	Comment
Rated insulation RMS voltage, basic insulation	U_{Nm}	V	1600	IEC 61010-1 conditions - over voltage cat III - pollution degree 2
Rated insulation RMS voltage, reinforced insulation	U_{Nm}	V	300	IEC 61010-1 conditions - over voltage cat III - pollution degree 2
Rated insulation RMS voltage, basic insulation	U_{Nm}	V	1000	EN 50178 conditions - over voltage cat III - pollution degree 2
Rated insulation RMS voltage, reinforced insulation	U_{Nm}	V	600	EN 50178 conditions - over voltage cat III - pollution degree 2
RMS voltage for AC insulation test, 50/60 Hz, 1 min	U_d	kV	4.6	Between primary and secondary + shield
Insulation voltage between secondary and shield		V DC	200	Between secondary and shield
Insulation voltage between secondary status output		V DC	500	Between secondary and status output
Impulse withstand voltage 1.2/50 μ s	U_{Ni}	kV	8.5	
Clearance (pri. - sec.)	d_{Cl}	mm	9	Shortest distance through air
Creepage distance (pri. - sec.)	d_{Cp}	mm	9	Shortest path along device body
Comparative tracking index	CTI		600	

If insulated cable is used for the primary circuit, the voltage category could be improved with the following table (for single insulation) (IEC 61010-1 standard):

Cable insulated (primary)	Category
HAR03	1750 V CAT III
HAR05	1850 V CAT III
HAR07	1950 V CAT III

Environmental and mechanical characteristics

Parameter	Symbol	Unit	Min	Typ	Max	Comment
Ambient operating temperature	T_A	°C	-40		85	
Ambient storage temperature	$T_{A\text{st}}$	°C	-40		85	
Relative humidity	RH	%	20		80	Non-condensing
Dimensions						See drawing page 6
Mass	m	kg		1.08		

Electrical data

 At $T_A = 25\text{ °C}$, $\pm U_C = \pm 15\text{ V}$, unless otherwise noted.

 Lines with a * in the comment column apply over the $-40 \dots 85\text{ °C}$ ambient temperature range.

Parameter	Symbol	Unit	Min	Typ	Max	Comment
Primary continuous direct current	$I_{P\text{NDC}}$	A	-600		600	*
Primary nominal RMS current	I_{PN}	A			600	*
Primary current, measuring range	I_{PM}	A	-849		849	* Peak limit
Measuring resistance over supply voltage	R_M	Ω	0		5	See graph page 4
Secondary current	I_S	mA	-566		566	* Peak limit
Secondary nominal RMS current	I_{SN}	mA			400	*
Turns ratio	N_P / N_S			1:1500		*
Resistance of secondary winding	R_S	Ω		11		
Maximum primary withstand peak current ¹⁾	$\hat{I}_{P\text{max}}$	A	-3000		3000	@ pulse of 100 ms
Supply voltage DC	U_C	V	± 14.25	± 15	± 15.75	*
Current consumption	I_C	mA		122	128	Add I_S for total current consumption
				131	139	
RMS noise current 0 ... 10 Hz ²⁾	I_{no}	ppm			0.05	
RMS noise current 0 ... 100 Hz ²⁾					0.5	
RMS noise current 0 ... 1 kHz ²⁾					1	
RMS noise current 0 ... 10 kHz ²⁾					3	
RMS noise current 0 ... 50 kHz ²⁾					6	
Re-injected RMS noise on primary bus bar		μV			5	0 ... 50 kHz
Electrical offset current + self magnetization + effect of earth magnetic field ²⁾	I_{OE}	ppm		± 25	± 32	*
				± 28	± 36	
Offset stability ²⁾		ppm/month			1	
Linearity error ²⁾	ϵ_L	ppm		± 3	± 7	* @ $\pm I_{P\text{NDC}}$ range
				± 4	± 8	
Delay time to 90 % of the final output value for $I_{P\text{NDC}}$ step	t_{D90}	μs			1	di/dt of 100 A/ μs
di/dt accurately followed	di/dt	A/ μs		100		
Frequency bandwidth ($\pm 1\text{ dB}$)	BW	kHz		200		Small-signal bandwidth, 0.5 % of $I_{P\text{NDC}}$
Frequency bandwidth ($\pm 3\text{ dB}$)	BW	kHz		300		Small-signal bandwidth, 0.5 % of $I_{P\text{NDC}}$

Notes: ¹⁾ Single pulse only, not AC. The transducer may require a few seconds to return to normal operation when autoreset system is running

²⁾ All ppm figures refer to full-scale which corresponds to a secondary nominal RMS current (I_{SN}) of 400 mA.

Overload protection - Electrical specification - Status

The overload occurs when the primary current I_p exceeds a trip level such that the fluxgate detector becomes completely saturated and, consequently, the transducer will switch from normal operation to overload mode.

This trip level is guaranteed to be greater than 110 % of I_{PM} and its actual value depends on operating conditions such as temperature and measuring resistance.

When this happens, the transducer will automatically begin to sweep in order to lock on the primary current again and the measuring can resume when the primary current returns in the measuring range between $-I_{PM}$ and $+I_{PM}$.

In overload mode, the secondary current I_s generated is a low frequency signal between -0.566 A and 0.566 A.

The overload conditions will be:

- The potential-free contact (normal operation status) between pin 3 and 8 (of the D-sub connector) switches off, this contact becomes open.
- The green LED indicator (normal operation status) turns off.

Max voltage pin 3 and pin 8, off-State	100 V
Max current pin 3 and pin 8, on-State	1000 mA
On-State resistance pin 3 and pin 8:	30 mΩ (max)

Maximum measuring resistor versus primary current and temperature

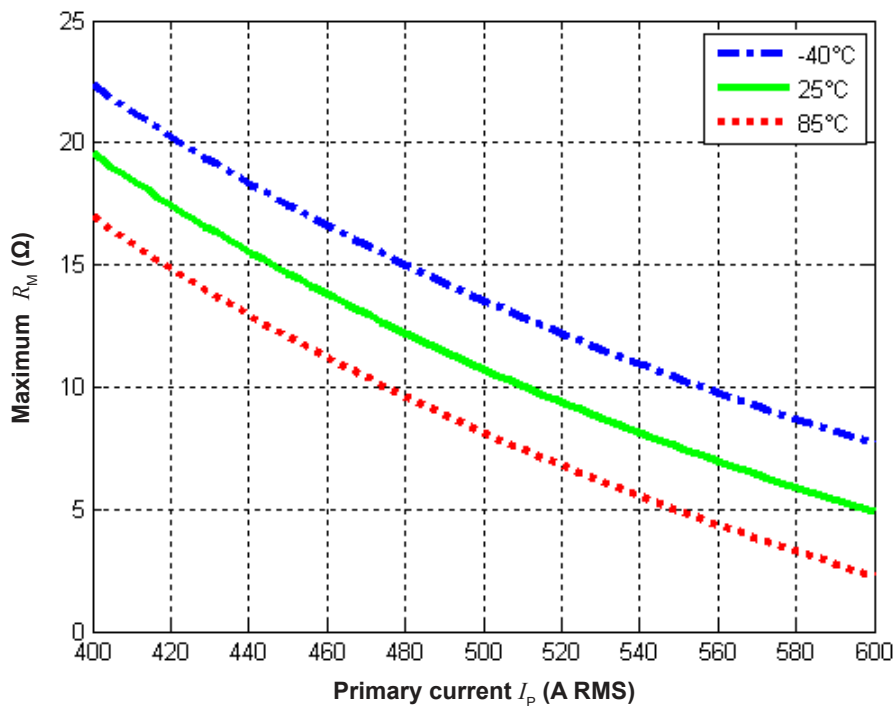

Status/Interlock port wiring

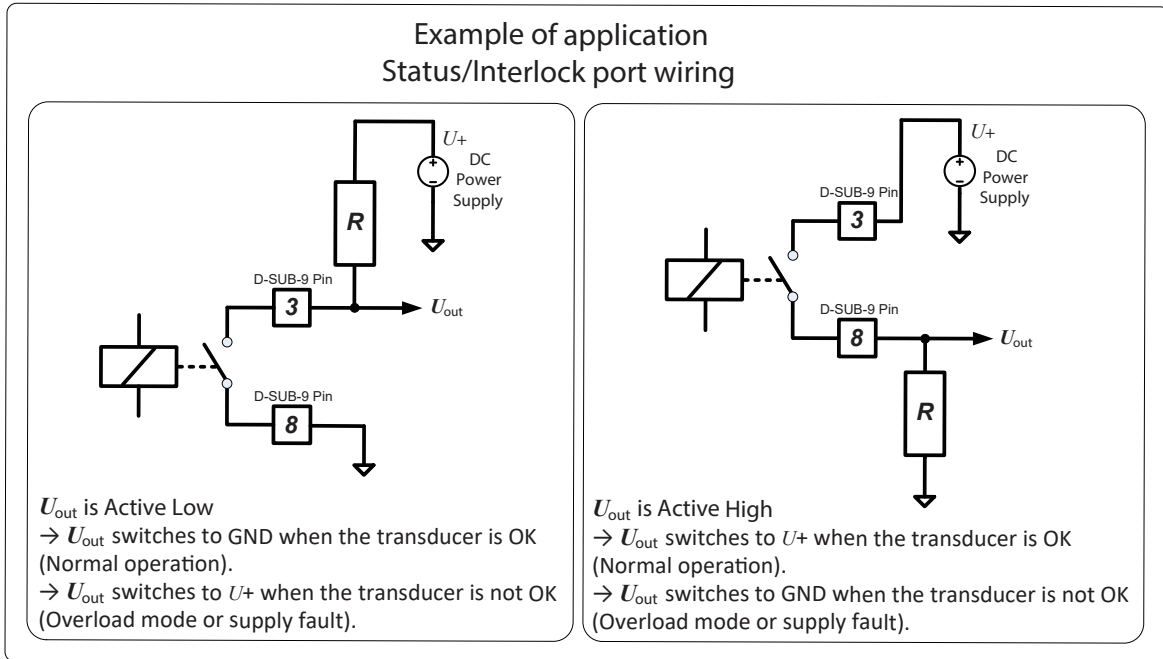

Safety

This transducer must be used in limited-energy secondary circuits according to IEC 61010-1.



This transducer must be used in electric/electronic equipment with respect to applicable standards and safety requirements in accordance with the manufacturer's operating instructions.



Caution, risk of electrical shock

When operating the transducer, certain parts of the module can carry hazardous voltage (eg. primary connection, power supply). Ignoring this warning can lead to injury and/or cause serious damage.

This transducer is a build-in device, whose conducting parts must be inaccessible after installation.

A protective housing or additional shield could be used.

Main supply must be able to be disconnected.

Dimensions (in mm)

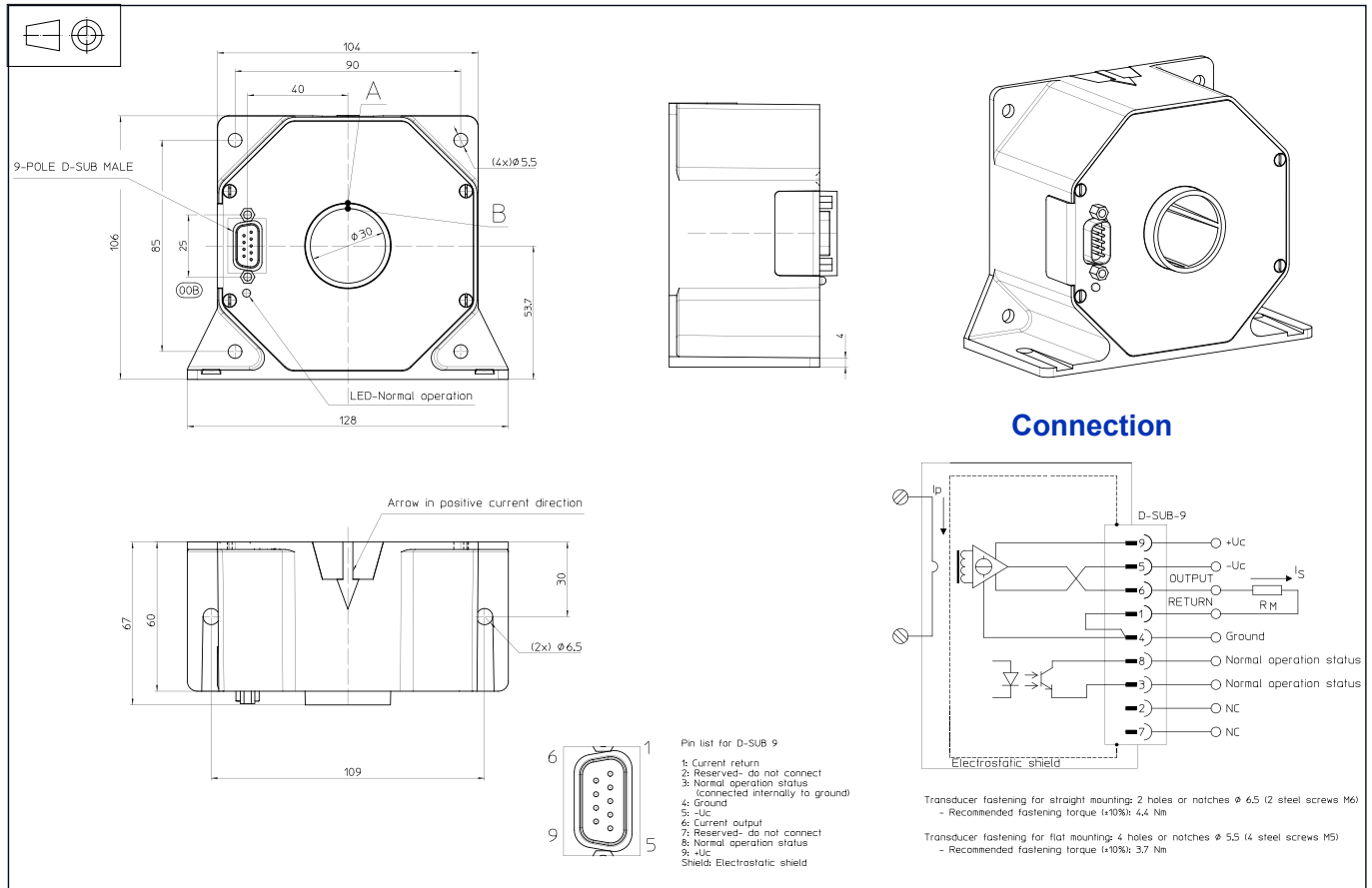

Connection

- Normal operation status (Pins 3 and 8)
Normal operation means:
 - $\pm 15\text{ V } (\pm U_C)$ present
 - zero detector is working
 - primary current $\leq 110\%$ of I_{PM}
 - green LED indicator is lit.

Contact (Pins 3 and 8)	Description
Closed	The transducer is OK (Normal operation)
Open	The transducer is not OK (Overload mode or supply fault)

Remarks

I_S is positive when I_p flows in the direction of the arrow. We recommend that a shielded output cable and plug are used to ensure the maximum immunity against electrostatic fields. Pin 4 should be connected to cable and connector shield to maintain lowest output noise. Temperature of the primary conductor should not exceed 100 °C.

Mechanical characteristics

- General tolerance $\pm 0.3\text{ mm}$
- Transducer fastening
 - Straight mounting: 2 holes $\phi 6.5\text{ mm}$, 2 x M6 steel screws, Recommended fastening torque 4.4 N·m
 - Flat mounting: 4 holes $\phi 5.5\text{ mm}$, 4 x M5 steel screws, Recommended fastening torque 3.7 N·m
- Connection of secondary on D-SUB-9, connector UNC 4-40
- All mounting recommendations are given for a standard mounting. Screws with flat and spring washers.
- Primary through hole $\phi \leq 30\text{ mm}$
- Installation of the transducer must be done unless otherwise specified on the datasheet, according to LEM Transducer Generic Mounting Rules. Please refer to LEM document N°ANE120504 available on our Web site: [Products/Product Documentation](#).