

THIS DRAWING IS UNPUBLISHED. RELEASED FOR PUBLICATION  
 © COPYRIGHT 19 BY AMP INCORPORATED. ALL INTERNATIONAL RIGHTS RESERVED.

LOC	DIST	P	F	ZONE	LTR	DESCRIPTION	DATE	APPD
FT	38				C	REDRAWN	7-6-90	-
					D	OBS 1-4 PER ECN BD6177	06/19/92	TS
					E	REV PER EC 0020-191-96	14 AUG 96	JS

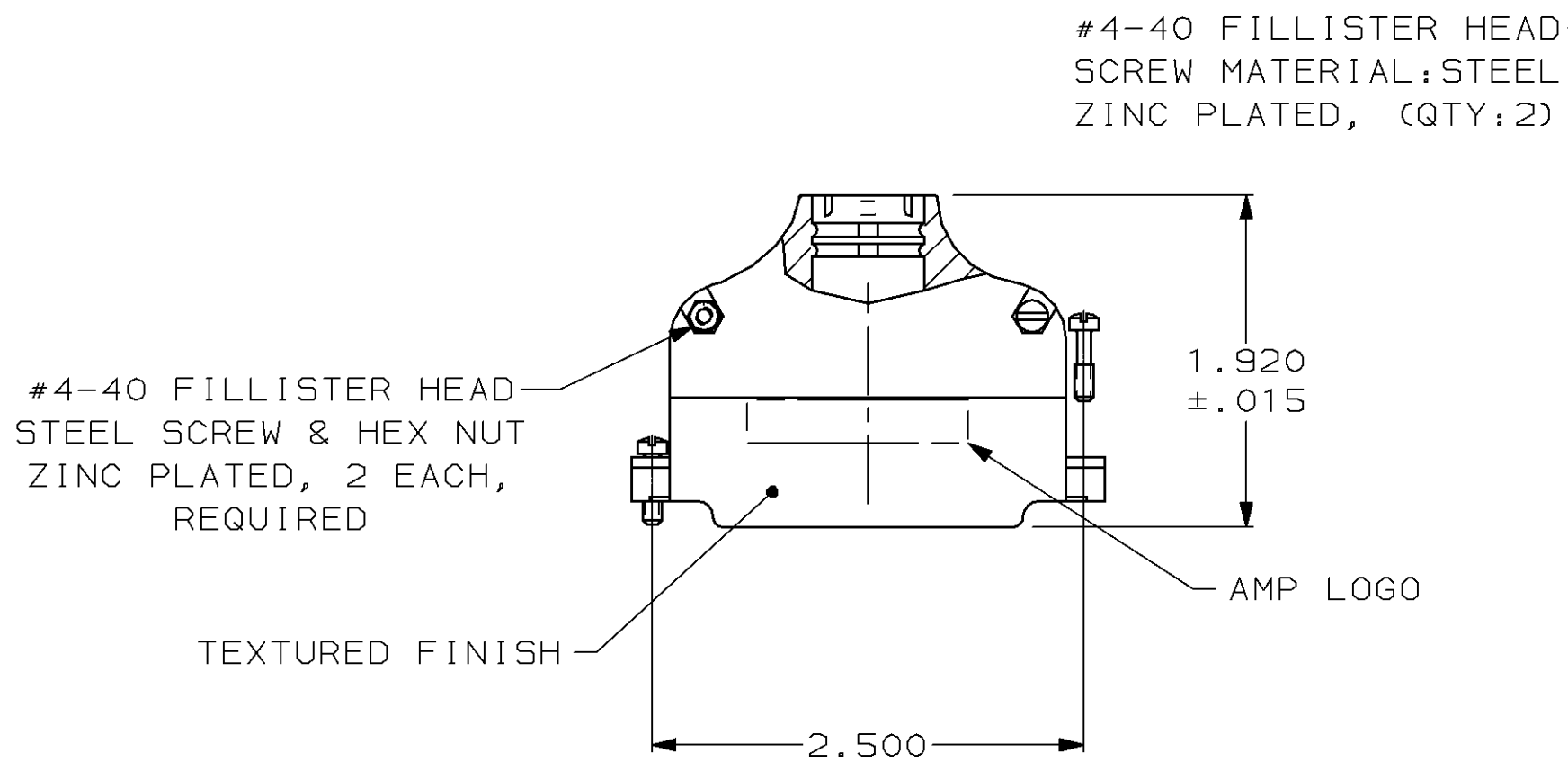
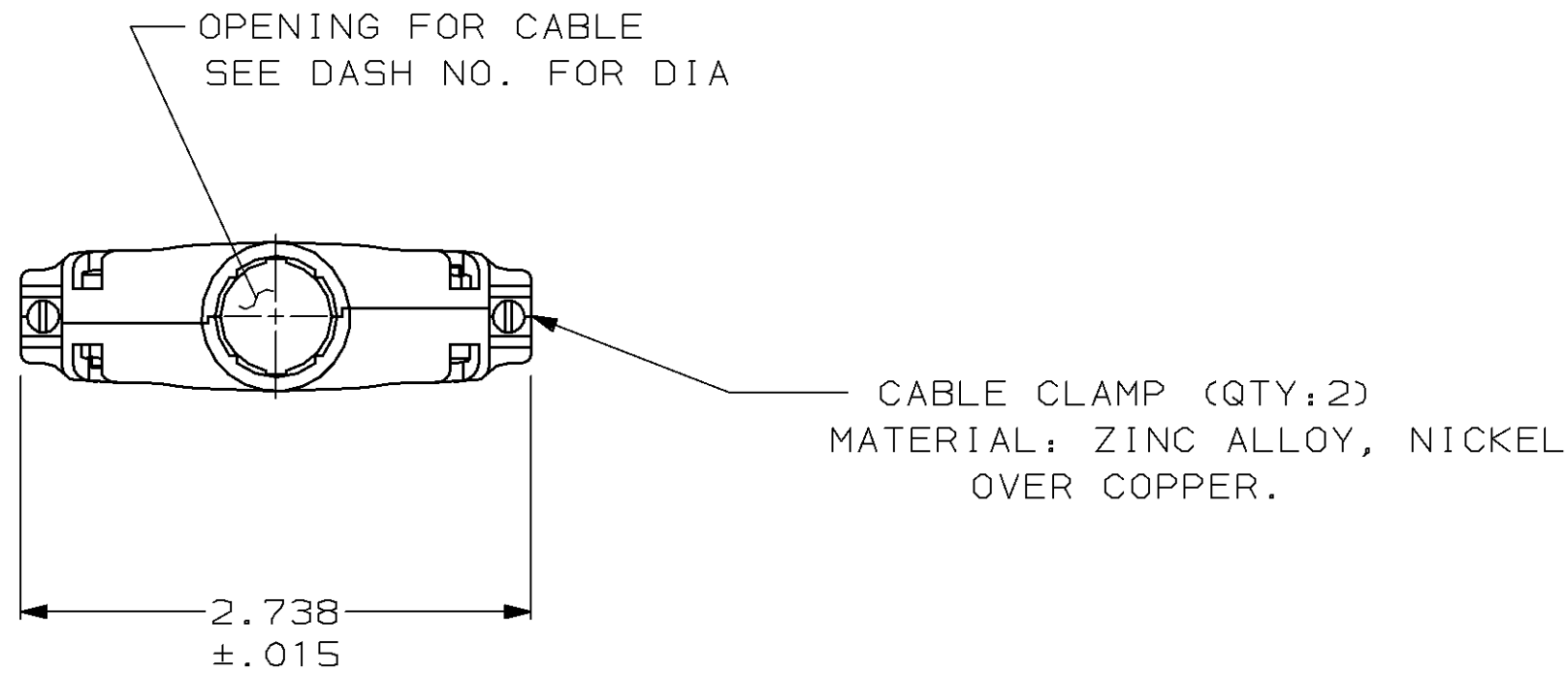

NECK IDENT	REMARKS	CABLE DIA	PART NO.
P	AS SHOWN	.530	2-745174-7
	SUPPLIED W/O MTG SCREWS W/O AMP LOGO (BULK PACKED)	.350	1-745174-6
F	AS SHOWN	.650	2-745174-6
T	BULK PACKED	.575	2-745174-5
R		.500	2-745174-4
N		.425	2-745174-3
J		.350	2-745174-2
F	SUPPLIED W/O MTG SCREWS W/ AMP LOGO (BULK PACKED)	.650	2-745174-1
T		.575	2-745174-0
R		.500	1-745174-9
N		.425	1-745174-8
J		.350	1-745174-7
F	SUPPLIED W/O MTG SCREWS W/ AMP LOGO	.350	1-745174-5
OBSOLETE		.425	1-745174-4
OBSOLETE		.500	1-745174-3
OBSOLETE		.575	1-745174-2
		.650	1-745174-1
	AS SHOWN	.350	745174-5
		.425	745174-4
		.500	745174-3
		.575	745174-2
		.650	745174-1

1. PARTS PACKAGED UNASSEMBLED.

DO NOT SCALE PRINT. UNLESS SPECIFIED DIMENSIONS IN INCHES TOLERANCES ON : 2 PLC DEC ± - 3 PLC DEC ± .005 ANGLES ± -	DR 7/6/90 A.STAUB BG CHK 9/10/90 J.MCCLINTON APPD 9/11/90 BOB TAYLOR	AMP INCORPORATED Harrisburg, Pa. 17105		
MATERIAL SEE CALLOUTS	APPD 9/11/90 J.ASSINI PRODUCT SPEC -			NAME CABLE CLAMP KIT, SIZE 4, 37 POSITION, 180°, AMPLIMITE™ SERIES
FINISH SEE CALLOUTS	APPLICATION SPEC -	SIZE <b>C</b>	FSCM NO 00779	DRAWING NO 745174
	WEIGHT -	SCALE 1:1		SHEET 1 OF 1