

# Industrial Modbus Ethernet to Serial Gateways

MESR900 Series - Copper Models

B+B SMARTWORX

Powered by

ADVANTECH



## PRODUCT FEATURES

- Ethernet enable Modbus RS-232/422/485
- Modbus TCP, ASCII & RTU
- Modbus flexibility – serial & Ethernet, Masters & slaves
- Modbus messaging priority control
- View messaging status in real time
- Easy configuration software
- UL Class 1 Division 2
- NEMA TS2 (MESR901)

MESR900 Modbus Gateways bridge devices on Modbus serial networks (RS-232, RS-422 or RS-485) with those on Modbus TCP networks, allowing seamless integration. Serial ports can be accessed over a LAN or WAN using Direct IP Mode connections. Supporting up to 16 masters and 32 slaves, these gateways feature autodetecting 10/100 copper and fiber optic options. Easy-to-use software is designed for Windows 2000, 2003 Server, XP, Vista, 2008 Server and Windows 7. Serial data rates up to 230 kbps ensure maximum network flexibility.

MESR9xx gateways are built for use in industrial environments, featuring a slim IP30 DIN rail mountable case. They operate from a range of DC power supply voltages and have pluggable terminal block connectors. An external power supply, sold separately, is required. The MESR92x units have an additional Ethernet port which functions much like an Ethernet Switch, allowing pass-through connectivity for other Ethernet devices. This port can also be used to “daisy chain” multiple gateways. MESR90x units have one Ethernet port. B+B Electronics' Vlinx™ is your number one choice for Ethernet to Serial conversion.

## IN THE FIELD

### Teaming Data Systems for Portable Power

Industry: Power & Energy  
Product: Modbus Gateways



## IN THE FIELD

### Transwestern Pipeline Maximizes Gas Chromatography Investment

Industry: Petroleum, Oil & Gas  
Product: Modbus Gateways



## ORDERING INFORMATION

MODEL NUMBER	SERIAL PORTS	SERIAL CONNECTOR	ETHERNET PORT	ETHERNET CONNECTOR
MESR901 †	1	DB9 or Terminal Block	(1) Copper	RJ45
MESR902T	2	Terminal Block	(1) Copper	RJ45
MESR921	1	DB9 or Terminal Block	(2) Copper	(2) RJ45
MESR922T	2	Terminal Block	(2) Copper	(2) RJ45

\* Fiber options available.

† NEMA TS2

## ACCESSORIES

MDR-20-24 - DIN rail mount power supply 24VDC, 1.0 A output power

MDR-40-24 - DIN rail mount power supply 24VDC, 1.7 A output power

DRPM25 - 35mm DIN Rail to Panel Mount Bracket, 25mm wide

ERS35 - DIN Rail 1 Meter 35mm Steel

# Industrial Modbus Ethernet to Serial Gateways

## MESR900 Series - Copper Models



### SPECIFICATIONS

#### SERIAL TECHNOLOGY

RS-232	TD, RD, RTS, CTS, DTR, DCR, DTD, GND
RS-485 2-Wire	Data A(-), Data B(+), GND
RS-422/485 4-Wire	TDA(-), TDB(+), RDA(-), RDB(+), GND
Serial Connector	DB9M or Removable Terminal Blocks; 12 to 28 AWG
Data Rate	Up to 230.4 Kbps

#### POWER

Source	External
Input Voltage	10 to 48 VDC (58 VDC Maximum)
Connector	Removable Terminal Block (12 – 28 AWG)

#### POWER CONSUMPTION

MESR90X	4.0 Watts
MESR92X	6.0 Watts

#### MECHANICAL

LED Indicators	Serial Port, Ethernet Link, Ready
Switches	Reset Button
Dimensions	MESR90x: 11.94 x 8.03 x 2.96 cm (4.70 x 3.16 x 1.16 in) MESR92x: 14.86 x 10.11 x 2.96 cm (5.85 x 3.98 x 1.16 in)
Weight	MESR90x: 149.7 g (0.33 lbs) MESR92x: 204.1 g (0.45 lbs)

#### ENVIRONMENTAL

Operating Temperature	-40 to 80°C (-40 to 176°F)
Operating Humidity	0 to 95% Non-condensing
MTBF MESR90X	~ 132309 hours
MTBF MESR92X	~ 102593 hours
MTBF Calc Method	Parts Count Reliability Prediction

#### NETWORK

Serial Memory	8 KB per port
Network Memory	4 KB
LAN	10/100 Mbps Auto-detecting
Ethernet	IEEE 802.3 auto detecting & auto MDI/MDX 10/100

#### PROTOCOLS

Protocols	TCP, IPv4, ARP, HTTP 1.0, ICMP/PING, DHCP/BOOTP
IP Mode	Static, DHCP
TCP	User definable

#### OTHER

Mode	Modbus RTU Master / Slave Modbus ASCII Master/Slave
Search	Serial direct COM and Ethernet Auto Search or specific IP
Diagnostics	Display PC IP, ping, test VCOM, save test config. (text readable)
Firmware Upgrade	Vlinx Manager

#### ETHERNET PASS-THROUGH PORT (MESR92X)

Standards	IEEE 802.3, 802.3u, 802.3x
Processing Type	Store and Forward with 802.3x full duplex, non blocking flow control
Flow Control	IEEE 802.3x flow control, back pressure flow control
MAC Address Table	2K

#### CONFIGURATION SOFTWARE

Vlinx Manager	Windows 2000, XP (32/64 bit), 2003 Server (32/64 bit), Vista (32/64 bit), 2008 Server (32/64 bit), Win 7 (32/64 bit)
---------------	--

#### REGULATORY / CERTIFICATIONS / SAFETY

Compliance	FCC, CE, NEMA TS2 (MESR901) UL Listed, File E222870 UL Class 1 Division 2 Groups A, B, C, D (HAZLOC), File E245458
------------	--

### MECHANICAL DIAGRAM - MESR90X MODELS

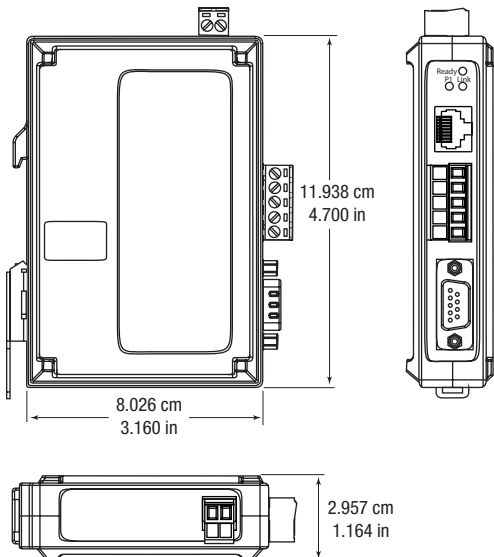

### MECHANICAL DIAGRAM - MESR92X MODELS

