

TOSHIBA Bipolar Linear Integrated Circuit Silicon Monolithic

# TA31273FN

## AM RF/IF Detector IC

The TA31273FN is an RF/IF detector IC for AM radio. The IC incorporates an RF amp, 2-level comparator, and local x8 circuit.

### Features

- RF frequency: 240 to 450 MHz
- IF frequency: 10.7 MHz
- Operating voltage range: 3.0 to 5.5 V
- Current dissipation: 6.8 mA (typ.)  
(Not operating local oscillator)
- Current dissipation at BS: 0 μA (typ.)
- Small package: 20-pin SSOP (0.65-mm pitch)

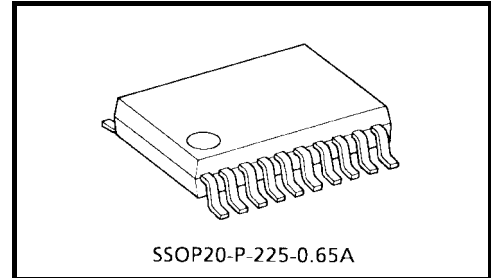

Weight: 0.09 g (typ.)

### Block Diagram

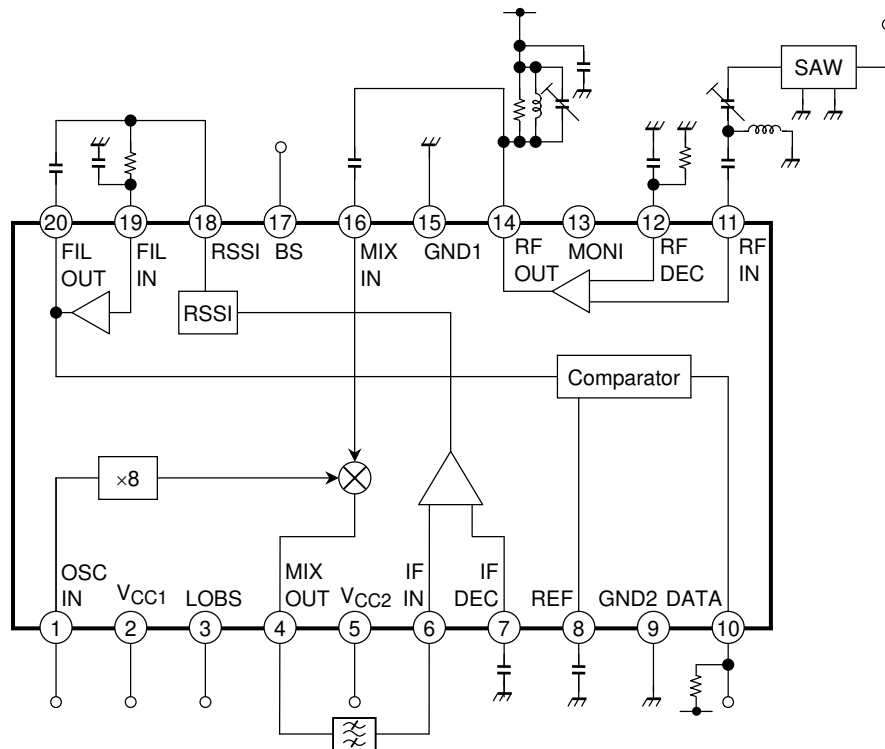

## Pin Function (The Values Of Resistor And Capacitor In The Internal Equivalent Circuit Are Typical.)

Pin No.	Pin Name	Function	Internal Equivalent Circuit
1	OSC IN	Local oscillator input pin.	
2	VCC1	Power supply pin 1.	—
3	LOBS	Lo switch pin. H: x8 circuit in operation Lo: Through pass	
4	MIX OUT	Mixer output pin.	
5	VCC2	Power supply pin 2.	—
6	IF IN	IF amp input pin.	
7	IF DEC	IF amp input pin. Used as a bias coupling pin.	
8	REF	AM comparator REF pin.	
9	GND2	GND pin 2.	—
10	DATA	AM waveform shaping output pin. Open collector output. Connect a pull-up resistor.	

Pin No.	Pin Name	Function	Internal Equivalent Circuit
11	RF IN	RF signal input pin.	
12	RF DEC	Emitter pin for internal transistor.	
14	RF OUT	RF amp output pin.	
13	MONI	Since this pin is connected to an internal circuit, it should either be left open or connected to GND.	
15	GND1	GND pin 1.	—
16	MIX IN	Mixer input pin.	
17	BS	Battery saving pin.	
18	RSSI	RSSI output pin.	
19	FIL IN	AM LPF input pin.	
20	FIL OUT	AM LPF output pin.	

Equivalent circuits are given to help understand design of the external circuits to be connected. They do not accurately represent the internal circuits.

**Functions**

**1. Waveform shaper circuit (comparator)**

The output data (pin 10) are inverted.

**2. RSSI function**

DC potential corresponding to the input level of IF IN (pin 6) is output to RSSI (pin 18). Output to RSSI (pin 18) is converted to a voltage by the internal resistance. Thus, connecting external resistance R to pin 18 varies the gradient of the RSSI output as shown below. Note that due to the displacement of temperature coefficients between external resistor R and the internal IC resistor, the temperature characteristic of the RSSI output may change. Also, the maximum RSSI value should be  $V_{CC} - 1$  V.

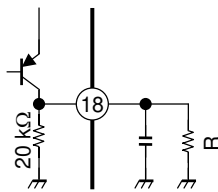

Figure 1

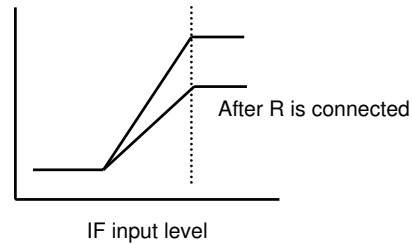

Figure 2

**3. V<sub>CC</sub> pin and GND pin**

Use the same voltage supply source for V<sub>CC1</sub> (pin 2) and V<sub>CC2</sub> (pin 5) (or connect them). Also, use the same voltage supply source for GND1 (pin 15) and GND2 (pin 9) (or connect them).

**4. Local oscillator circuit**

The local oscillator circuit is external-input-only. Input to pin 1 at a level from 95 to 105dBμV. By switching the Lo switch (LOBS), the frequency set by the external circuit can be used as-is without using the x8 circuit.

Lo Switch (LOBS)	H	L
Local oscillation status	x8 circuit in operation	x8 circuit halted/through pass

**5. RF amp current adjustment**

The RF amp current dissipation can be regulated by varying resistor R as shown in the figure below. When R = 1 kΩ, the current dissipation is approximately 800 μA.

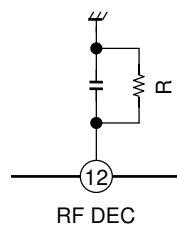

Figure 3

**6. Battery-saving (BS) function and Lo switch LOBS function**

The IC incorporates a battery-saving function and a Lo switch function. These functions offer the following selection.

BS Pin/LOBS Pin	Circuit Status in the IC	IC Current Dissipation (at no signal)
H/H	Circuits in operation <ul style="list-style-type: none"> <li>• x8 circuit</li> <li>• Mixer</li> <li>• RF amp</li> <li>• Comparator</li> <li>• IF amp</li> <li>• RSSI</li> <li>• Comparator capacitor charger circuit</li> </ul>	6.8 mA (typ.)
H/L	x8 circuit only halted, Frequency set by external circuit can be used as-is.	3.8 mA (typ.)
L/H	x8 circuit only in operation	3.0 mA (typ.)
L/L	All circuits halted	0 mA (typ.)

**7. RF amp gain 1**

RF amp gain 1 ( $G_V(RF) 1$ ) is a reference value calculated as follows. Measure  $G_{RF}$  in the following figure.

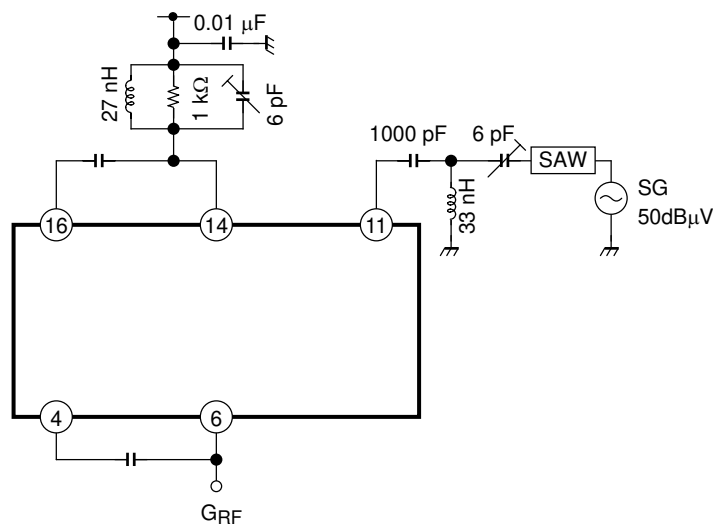

Figure 4

$G_V(RF) 1$  is calculated as follows:

$$G_V(RF) 1 = G_{RF} - G_V(MIX)$$

**8. IF amp gain**

The intended value is 70dB.

**9. Waveform-shaping output duty cycle**

The specified range of electrical characteristics is only available for single-tone.

**10. Local frequency range (after multiplying frequency by 8)**

When the multiplier circuit is used, the local frequency will be in the range 250.7 MHz to 439.3 MHz.

**11. Bit rate filter for AM**

The current AM bit rate filter is used as a quadratic filter.

If the filter is to be used at a rate other than 1200 bps, please change the filter constant.

**Quadratic filter (NRZ)**

**(The bit rate filter time constant takes into account the internal resistance RSSI (20 kΩ).)**

	R9	R8	C14	C13
1200 bps	47 kΩ	68 kΩ	1500 pF	4700 pF
2400 bps	47 kΩ	68 kΩ	680 pF	2200 pF
4800 bps	47 kΩ	68 kΩ	390 pF	1000 pF

When the filter constants shown below are used, it is not necessary to set the R9 constant value.

	R9	R8	C14	C13
1200 bps	—	20 kΩ	2200 pF	6800 pF
2400 bps	—	20 kΩ	1500 pF	3300 pF
4800 bps	—	20 kΩ	820 pF	1800 pF

In addition, the current AM bit rate filter can be used as a tertiary filter.

If the filter is to be used at a rate other than 1200 bps, please change the filter constant.

**Quadratic filter (NRZ)**

**(The bit rate filter time constant takes into account the internal resistance RSSI (20 kΩ).)**

	R10	R9	R8	C16	C14	C13
1200 bps	47 kΩ	68 kΩ	68 kΩ	3300 pF	560 pF	0.01 μF
2400 bps	47 kΩ	68 kΩ	68 kΩ	1500 pF	270 pF	4700 pF
4800 bps	47 kΩ	68 kΩ	68 kΩ	680 pF	150 pF	2200 pF

When the filter constants shown below are used, it is not necessary to set the R10 constant value.

	R10	R9	R8	C16	C14	C13
1200 bps	—	20 kΩ	20 kΩ	8200 pF	2200 pF	0.033 μF
2400 bps	—	20 kΩ	20 kΩ	3900 pF	1000 pF	0.015 μF
4800 bps	—	20 kΩ	20 kΩ	1800 pF	470 pF	6800 pF

## Maximum Ratings (Unless Otherwise Specified Ta = 25°C, Voltage Value is Determined by GND (TYP))

Characteristics	Symbol	Rating	Unit
Supply voltage	V <sub>CC</sub>	6	V
Current dissipation	P <sub>D</sub>	710	mW
Operating temperature range	T <sub>opr</sub>	-40~85	°C
Storage temperature range	T <sub>stg</sub>	-55~150	°C

The maximum ratings must not be exceeded at any time. Do not operate the device under conditions outside the above ratings.

## Operating available Range

(Unless Otherwise Specified Ta = 25°C, Voltage Value is Determined by GND(typ.))

Characteristics	Symbol	Test Circuit	Test Condition	Min	Typ.	Max	Unit
Operating voltage range	V <sub>CC</sub>	—	—	3.0	5.0	5.5	V

Operating ranges indicate the conditions for which the device is intended to be functional even with the electrical changes.

## Electrical Characteristics (Unless Otherwise Specified : Ta = 25°C, V<sub>CC</sub> = 5.0V , R<sub>fin</sub> = 314.9 MHz, AM = 90%, I<sub>fin</sub> = 10.7MHz , af = 600 Hz (square wave))

Characteristics	Symbol	Test Circuit	Test Condition	Min	Typ.	Max	Unit
Current dissipation at no signal	I <sub>ccq</sub>	2	V <sub>CC</sub> = 5.0 V, BS/LOBS = <sup>±</sup> H/H" F <sub>in</sub> (LO) = 40.7 MHz	5.1	6.8	8.5	mA
Current dissipation at battery saving	I <sub>cco</sub>	3	—	—	0	5	μA
RF amp gain 1	G <sub>V</sub> (RF) 1	—	V <sub>in</sub> (RF) = 50dBμV	—	20	—	dB
RF amp gain 2	G <sub>V</sub> (RF) 2	1 (5)	50 Ω input/output	-6.5	-3.5	-0.5	dB
RF amp input resistance	R (RF) IN	—	—	—	900	—	Ω
RF amp input capacitance	C (RF) IN	—	—	—	2.5	—	pF
RF amp output capacitance	C (RF) OUT	—	—	—	2	—	pF
Mixer conversion gain	G <sub>V</sub> (MIX)	1 (6)	—	17.5	21.5	25.5	dB
Mixer input resistance	R (MIX) IN	—	—	—	1.5	—	kΩ
Mixer input capacitance	C (MIX) IN	—	—	—	2.5	—	dB
Mixer output resistance	R (MIX) OUT	—	—	—	330	—	
Mixer intercept point	IP3	—	—	—	93	—	dBμV
IF operating frequency	f <sub>IF</sub>	—	—	—	10.7	—	MHz
IF amp input resistance	R (IF) IN	—	—	—	330	—	Ω
RSSI output voltage 1	V <sub>RSSI1</sub>	1 (1)	V <sub>in</sub> (IF) = 35dBμVEMF	0.1	0.3	0.5	V
RSSI output voltage 2	V <sub>RSSI2</sub>	1 (1)	V <sub>in</sub> (IF) = 65dBμVEMF	0.95	1.20	1.45	V
RSSI output voltage 3	V <sub>RSSI3</sub>	1 (1)	V <sub>in</sub> (IF) = 100dBμVEMF	1.9	2.3	2.7	V
RSSI output resistance	R <sub>RSSI</sub>	—	—	15	20	25	kΩ
Waveform shaping output duty cycle	DR	1 (2)	V <sub>in</sub> (IF) = 80dBμVEMF for single-tone	45	50	55	%
Data output voltage (L level)	V <sub>DATA L</sub>	1 (3)	I <sub>DATA L</sub> = 1 mA	—	—	0.4	V
Data output leakage current (H level)	I <sub>DATA H</sub>	1 (4)	—	—	—	2	μA
BS pin H-level input voltage	—	—	—	2.7	—	5.5	V
BS pin L-level input voltage	—	—	—	0	—	0.2	V
LOBS pin H-level input voltage	—	—	—	2.7	—	5.5	V
LOBS pin L-level input voltage	—	—	—	0	—	0.2	V

## Test Circuit

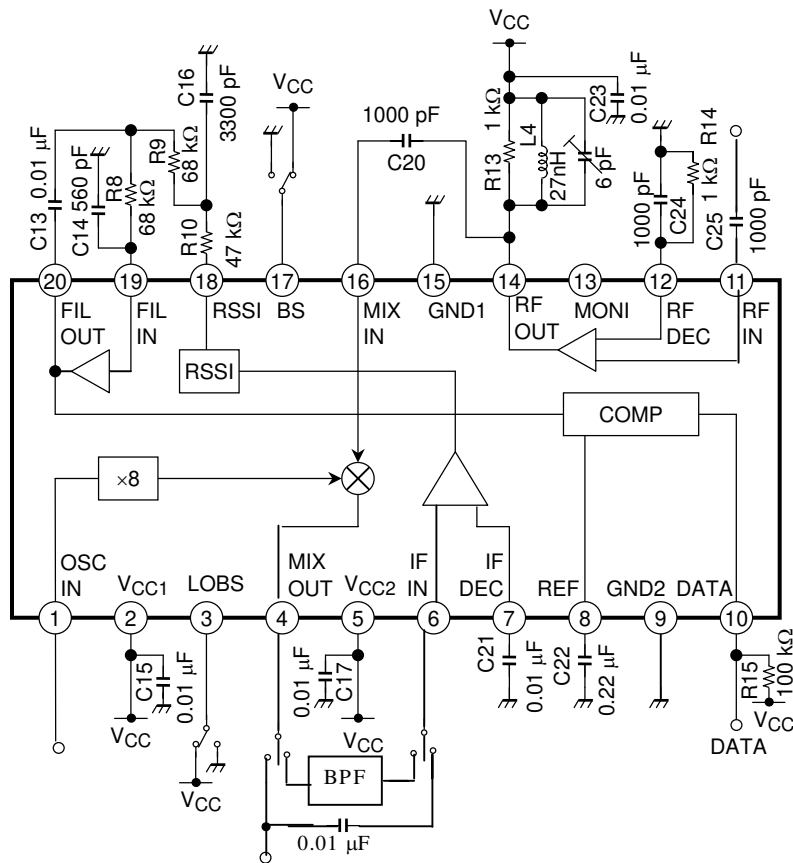

## Test Circuit 1

(1)  $V_{RSSI}$

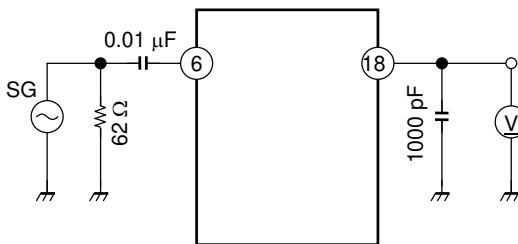

(2)  $D_R$

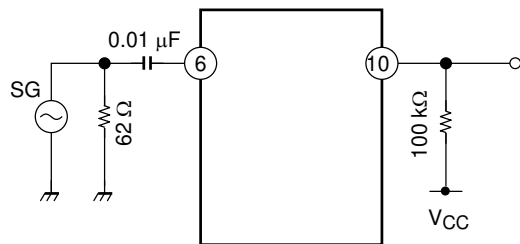

(3)  $V_{DATA}$

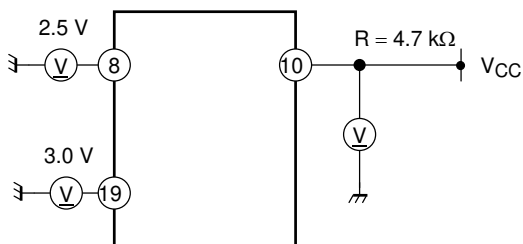

(4)  $I_{DATA H}$

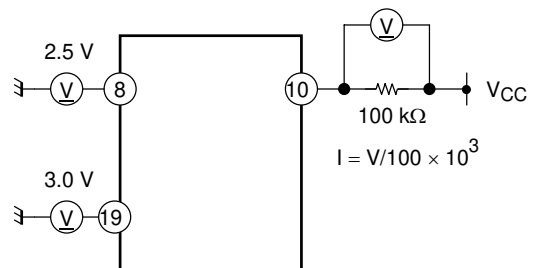



(5)  $G_V(RF) 2$

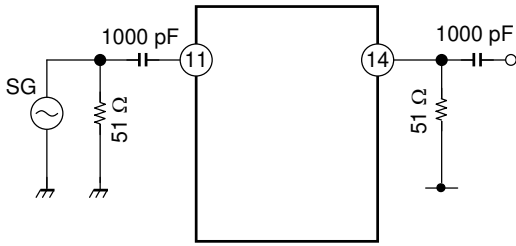

(6)  $G_V(MIX)$

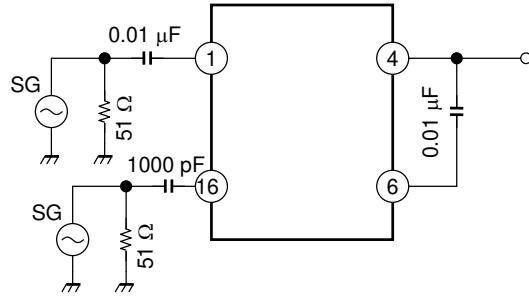

**Test Circuit 2**

$I_{ccqam}$

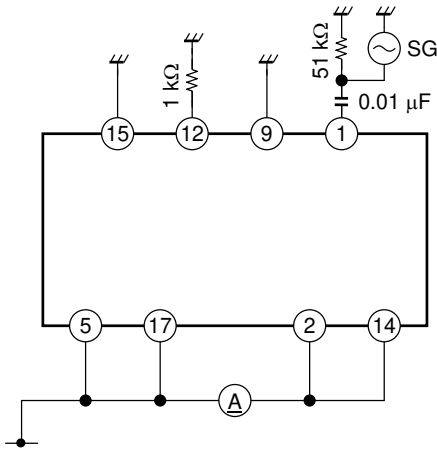

**Test Circuit 3**

$I_{cco}$

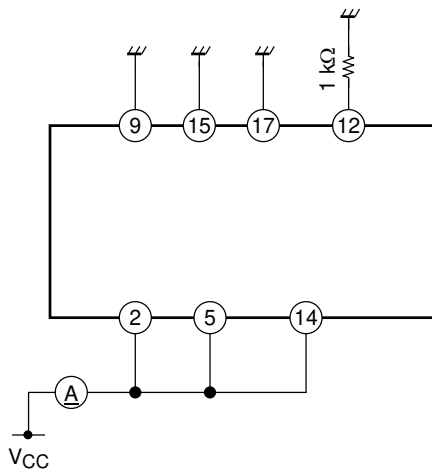

Reference data ( This is temperature characteristics data when it used evaluation boards. This is not guarantee on condition that it is stating except electrical characteristics. )

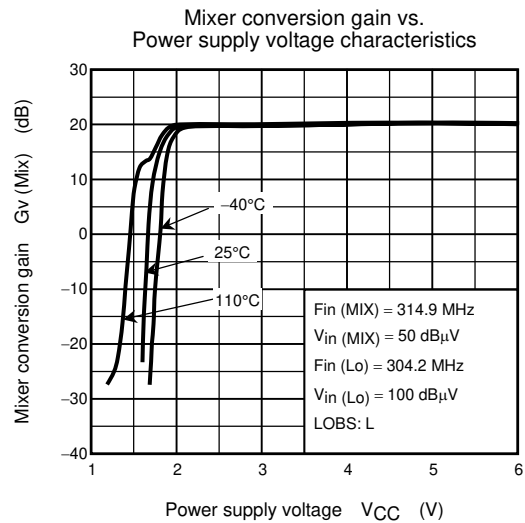
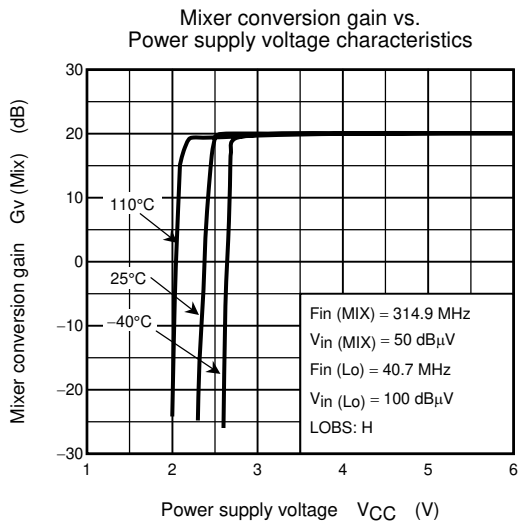
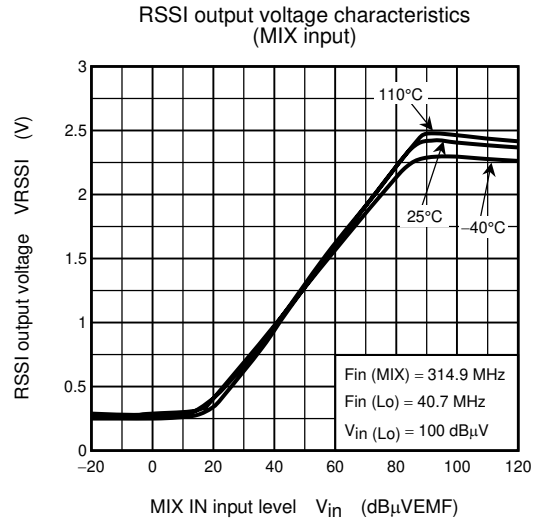
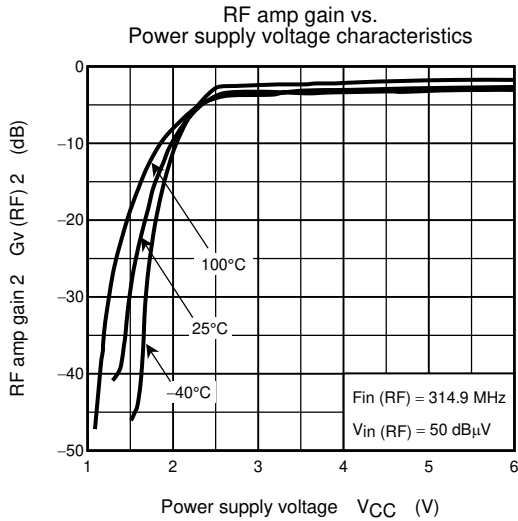
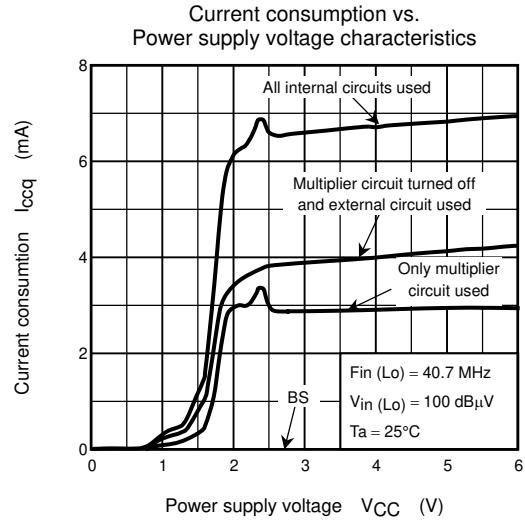
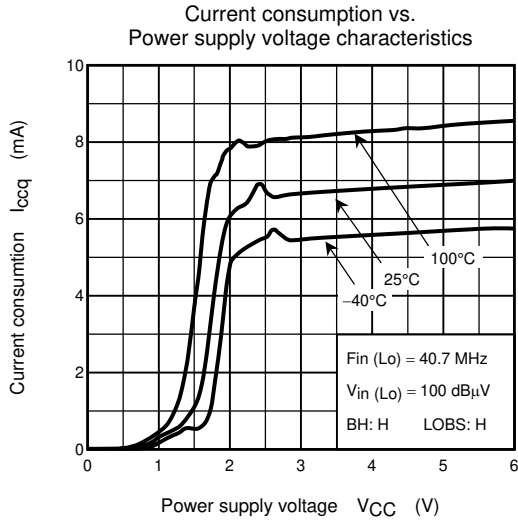

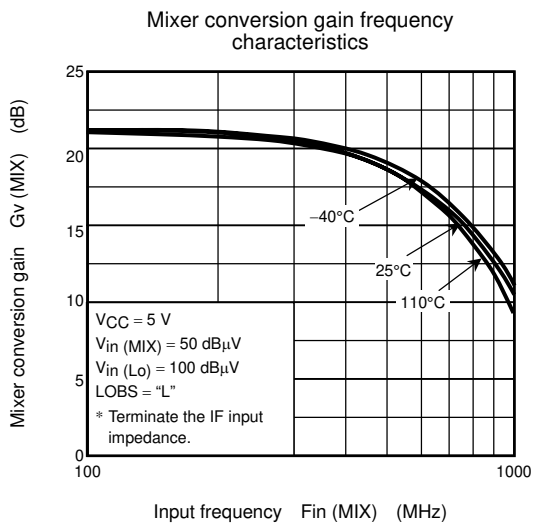
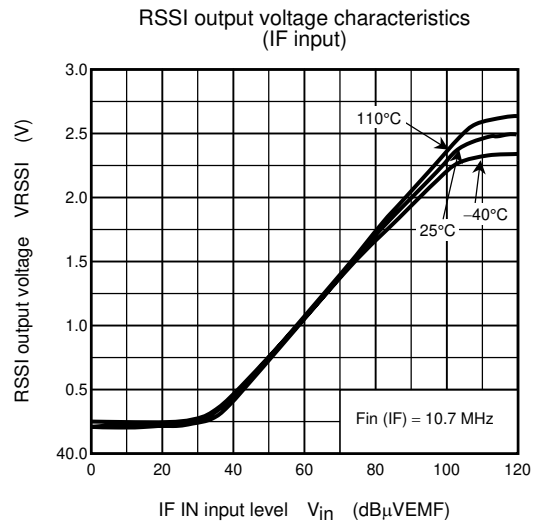
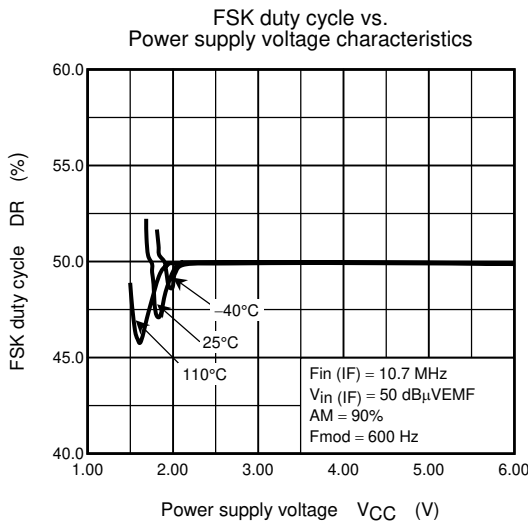
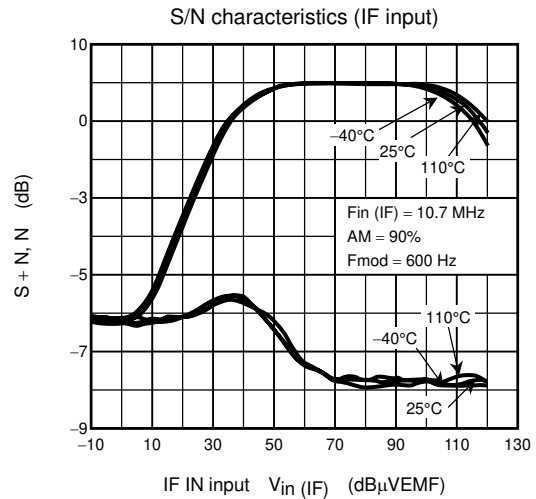
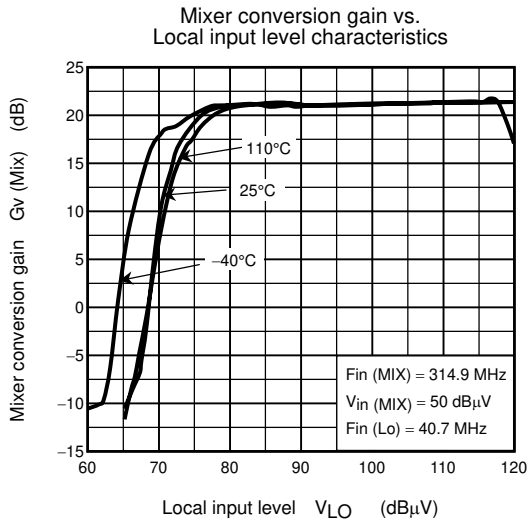

## Application Circuit

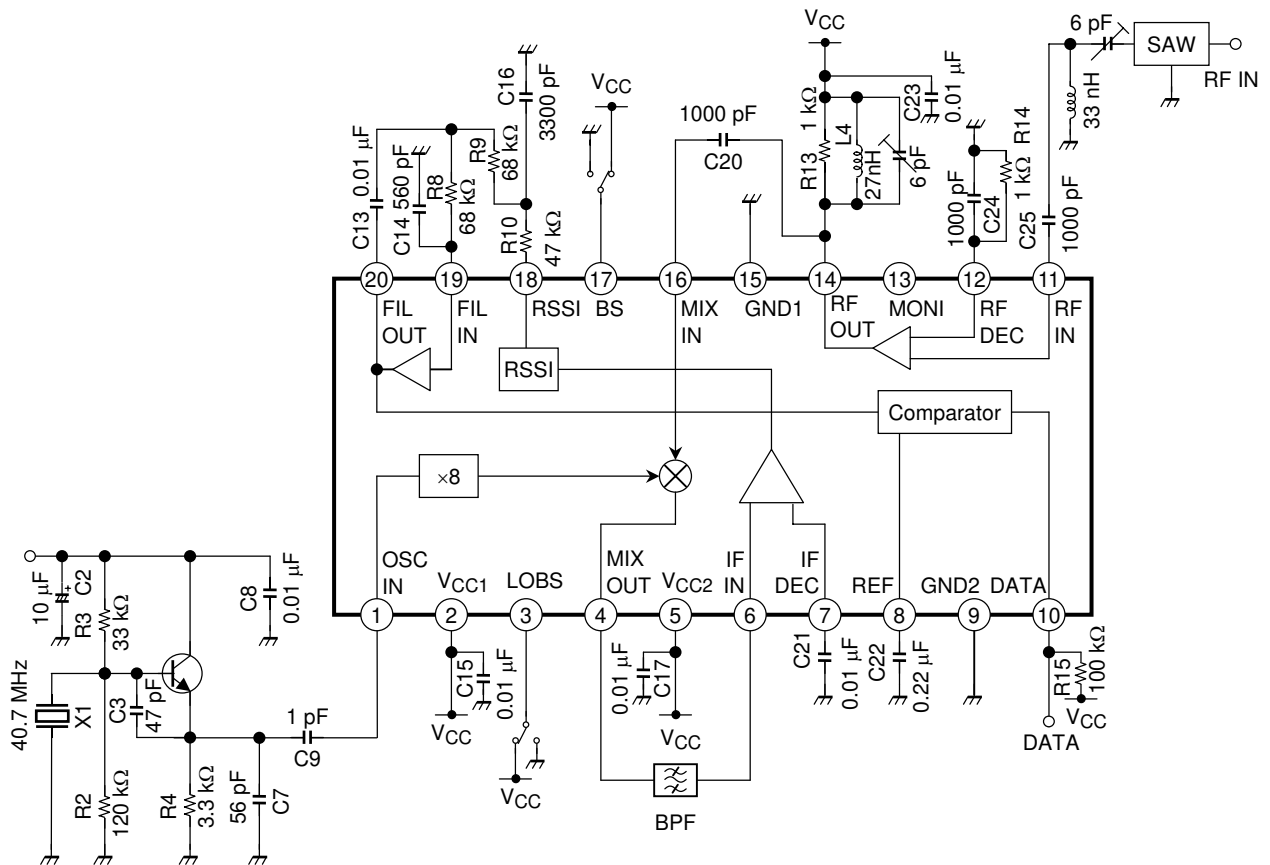

- X1 : TR-1 ( Tokyo Denpa Co., Ltd. )
- BPF : SFE10.7MA5-A ( Murata Manufacturing Co., Ltd. )
- SAW : SAFCH315MSM0T00B0S ( Murata Manufacturing Co., Ltd. )

**Package Dimensions**

SSOP20-P-225-0.65A

Unit : mm

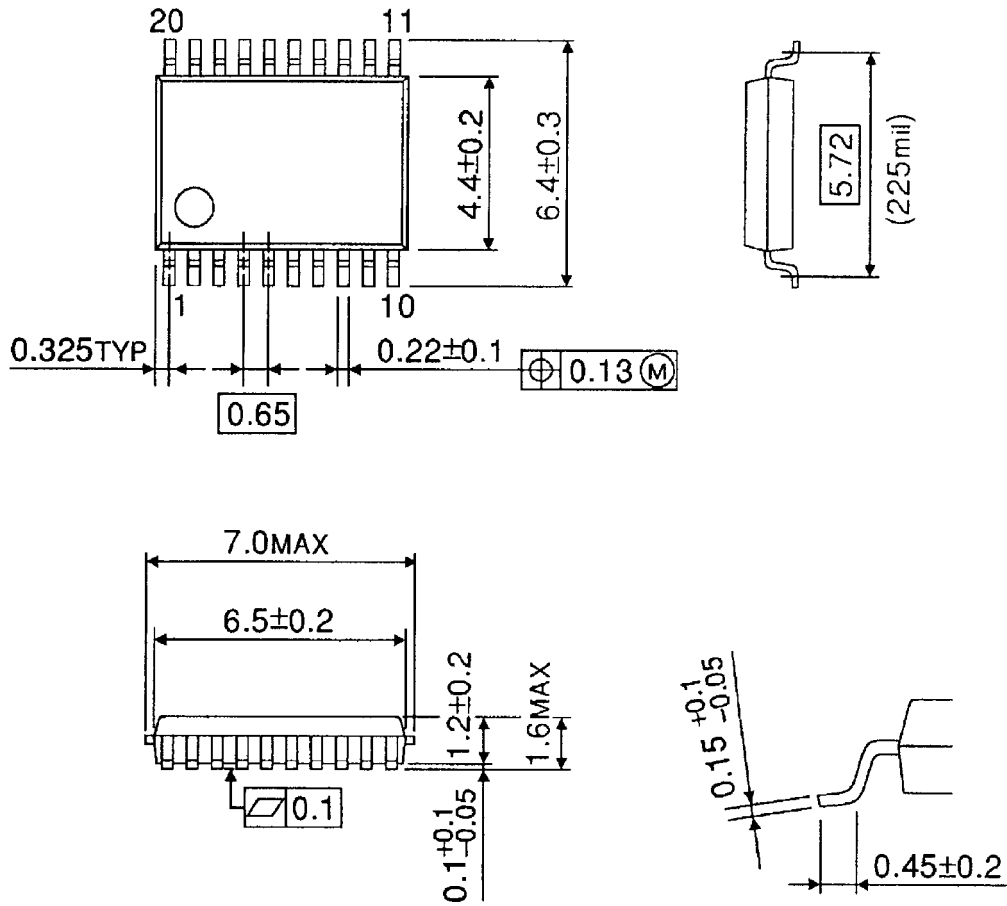

Weight: 0.09 g (typ.)

**RESTRICTIONS ON PRODUCT USE**

000707EBA

- TOSHIBA is continually working to improve the quality and reliability of its products. Nevertheless, semiconductor devices in general can malfunction or fail due to their inherent electrical sensitivity and vulnerability to physical stress. It is the responsibility of the buyer, when utilizing TOSHIBA products, to comply with the standards of safety in making a safe design for the entire system, and to avoid situations in which a malfunction or failure of such TOSHIBA products could cause loss of human life, bodily injury or damage to property.  
In developing your designs, please ensure that TOSHIBA products are used within specified operating ranges as set forth in the most recent TOSHIBA products specifications. Also, please keep in mind the precautions and conditions set forth in the "Handling Guide for Semiconductor Devices," or "TOSHIBA Semiconductor Reliability Handbook" etc..
- The TOSHIBA products listed in this document are intended for usage in general electronics applications (computer, personal equipment, office equipment, measuring equipment, industrial robotics, domestic appliances, etc.). These TOSHIBA products are neither intended nor warranted for usage in equipment that requires extraordinarily high quality and/or reliability or a malfunction or failure of which may cause loss of human life or bodily injury ("Unintended Usage"). Unintended Usage include atomic energy control instruments, airplane or spaceship instruments, transportation instruments, traffic signal instruments, combustion control instruments, medical instruments, all types of safety devices, etc.. Unintended Usage of TOSHIBA products listed in this document shall be made at the customer's own risk.
- The products described in this document are subject to the foreign exchange and foreign trade laws.
- The information contained herein is presented only as a guide for the applications of our products. No responsibility is assumed by TOSHIBA CORPORATION for any infringements of intellectual property or other rights of the third parties which may result from its use. No license is granted by implication or otherwise under any intellectual property or other rights of TOSHIBA CORPORATION or others.
- The information contained herein is subject to change without notice.