

DESCRIPTION

The EV1720DQ-00B is the evaluation board for the MP1720DQ-216, a low-power mono BTL class-D audio amplifier. It is one of MPS's products, low EMI, high efficiency, and full bridge output structure capable of delivering 2.7W into 4Ω speaker.

The EV board can also evaluate the MP1720DQ-0, MP1720DQ-3, MP1720DQ-6, MP1720DQ-9 and MP1720DQ-12 (with IC replacement).

ELECTRICAL SPECIFICATIONS

Parameter	Symbol	Value	Units
Supply Voltage	VIN	2.5 – 5.5	V
Gain	Av	21.6	dB

FEATURES

- Pass FCC-Radiated Emissions Standards with 24inch Cable without output filter
- 2.7W Into 4Ω with 5 V VIN @ 10% THD+N
- Up to 90% Efficiency
- Flexible Switching Frequency setting
- 2.5V~5.5V Operation from a Single Supply
- Low Noise (53μV Typical) with 3.3 V VIN
- Low Quiescent Current (4mA @3.3 V)

APPLICATIONS

- Cellular Phones
- PDAs
- MP3 Players
- Portable Audio

EV1720-00B EVALUATION BOARD

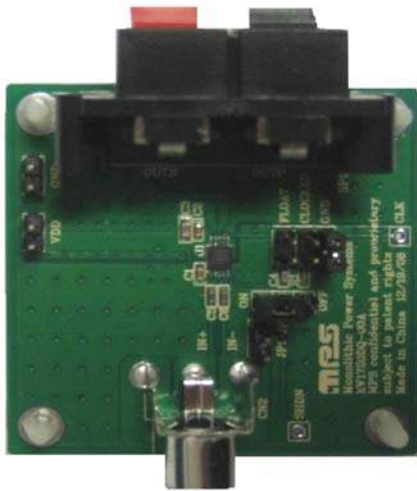

(L x W x H) 1.97" x 1.97" x 0.3"
(5.0cm x 5.0cm x 0.7cm)

Board Number	IC Number
EV1720DQ-00B	MP1720

EMI Spectrum Diagram

VIN=3.3V, R_{LOAD}=8Ω, no output filter,
CLK=GND, Near field,
6 inch unshielded twisted-pair-speaker cable

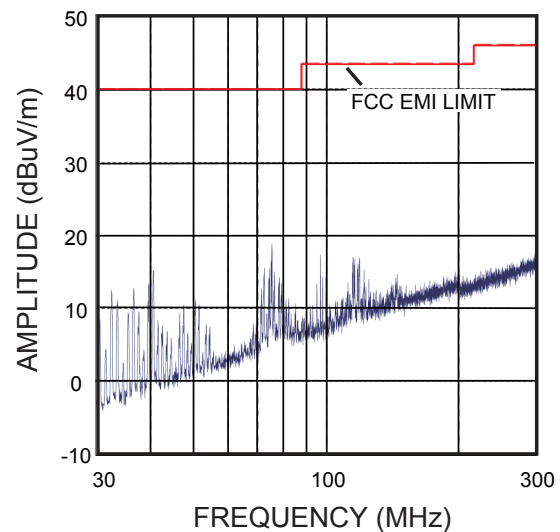

SCHEMATICS FOR ACTUAL APPLICATION

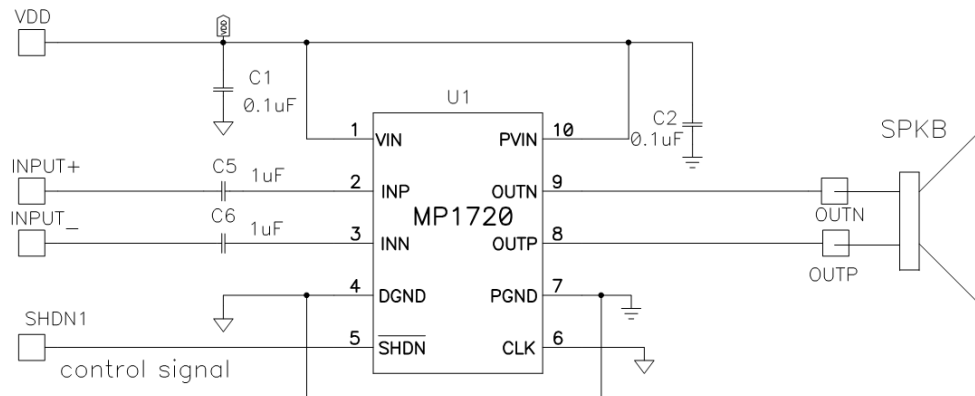

BILL OF MATERIALS FOR ACTUAL APPLICATION

Qty	Ref	Value	Description	Package	Manufacture	Part Number
2	C1,C2	0.1µF	Ceramic capacitor, X7R, 25V	0603	muRata	GRM188R71E104KA01
2	C5,C6	1µF	Ceramic capacitor, X5R, 6.3V	0603	muRata	GRM188R60J105KA01D
1	U1		Amplifier	QFN10	MPS	MP1720DQ-216

SCHEMATICS FOR TEST

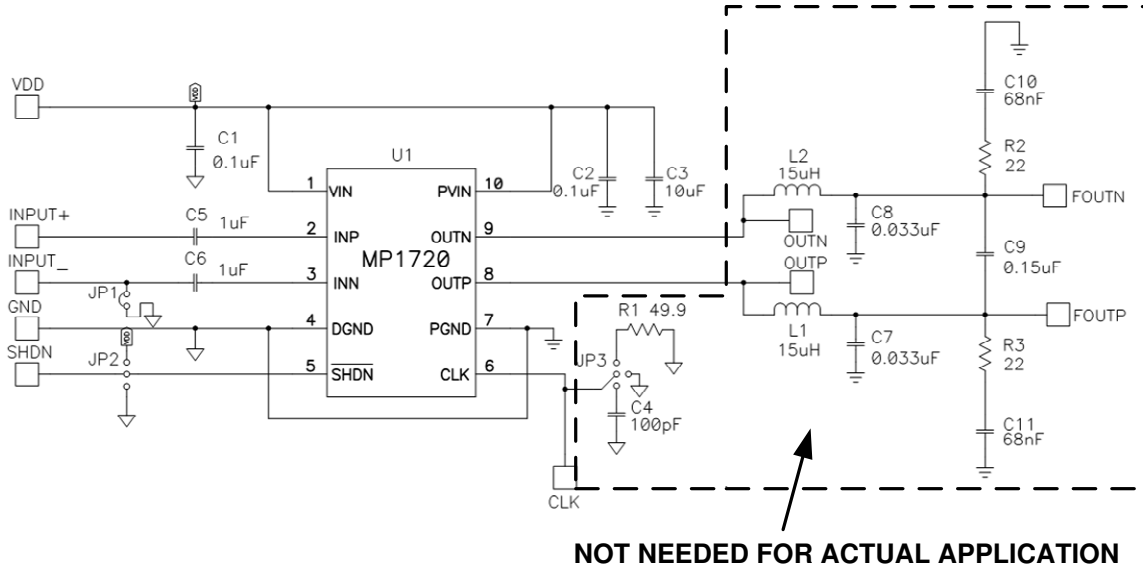

BILL OF MATERIALS FOR TEST

Qty	Ref	Value	Description	Package	Manufacture	Part Number
2	C1,C2	0.1µF	Ceramic capacitor, X7R, 25V	0603	muRata	GRM188R71E104KA01
1	C3 ⁽¹⁾	10µF	Ceramic capacitor, X5R, 10V	0805	muRata	GRM21BR61A106KE19L
1	C4	100pF	Ceramic capacitor, C0G, 50V	0603	muRata	GRM1885C1H101JA01D
2	C5,C6	1µF	Ceramic capacitor, X5R, 6.3V	0603	muRata	GRM188R60J105KA01D
2	C7,C8 ⁽²⁾	33nF	Ceramic capacitor, X7R, 50V	0603	muRata	GRM188R71H333KA61D
1	C9 ⁽²⁾	0.15µF	Ceramic capacitor, X7R, 50V	0805	TDK	C2012X7R1H154K
2	C10,C11 ⁽²⁾	68nF	Ceramic capacitor, X7R, 50V	0603	muRata	GRM188R71H683KA93D
2	L1,L2 ⁽²⁾	15µH	Inductor, 1.4A	D75F	TOKO	D75F-646CY-150M
1	R1	49.9Ω	Ceramic Resistor, 1%	0603	Yageo	RC0603FR-0749R9L
2	R2,R3 ⁽²⁾	22Ω	Ceramic Resistor, 1%	0603	Yageo	RC0603FR-0722RL
1	U1		Amplifier	QFN10	MPS	MP1720DQ-216
1	JP1		JUMPER/2PIN/0.1		any	
1	JP2		JUMPER/3PIN/0.1		any	
1	JP3		JUNPER/3PIN&3PIN/0.1		any	

Note:

1). It is required in system design.

2). These external components are used for performance test. For audio performance test, a LC low-pass filter (33nF, 15µH, 0.15µF) is required even if the analyzer has a low-pass filter. They are optional for normal operation

PRINTED CIRCUIT BOARD LAYOUT

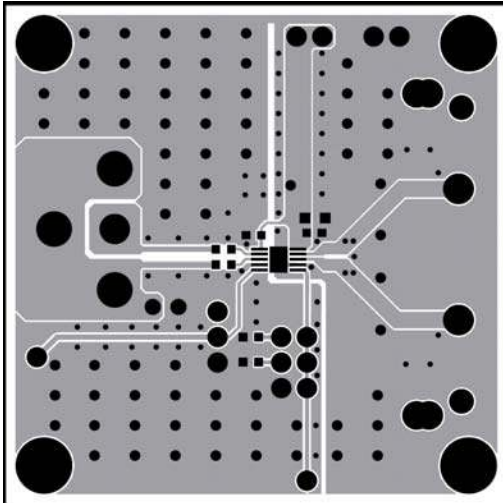

Figure 1—Top Layer

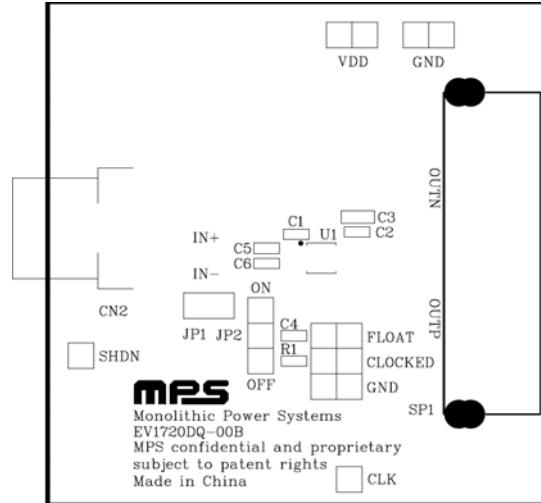

Figure 2—Top silk Layer

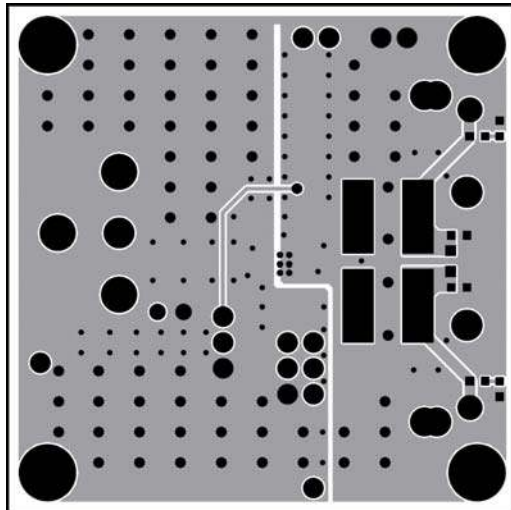

Figure 3—Bottom Layer

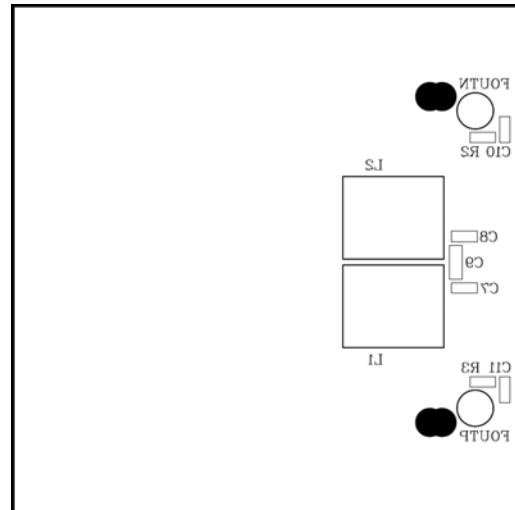

Figure 4—Bottom silk Layer

QUICK START GUIDE

This board is set up from the factory for MP1720 evaluation, which is a mono BTL low-power class-D audio amplifier (see Figure 5).

This EV board can also evaluate the MP1720DQ-0, MP1720DQ-3, MP1720DQ-6, MP1720DQ-9 and MP1720DQ-12 (with IC replacement).

For audio performance test, the LC low-pass filter is required even if the analyzer has a low-pass filter. So please use FOUTP and FOUTN for output terminals (see Figure 6).

For more information, consult the MP1720 datasheet.

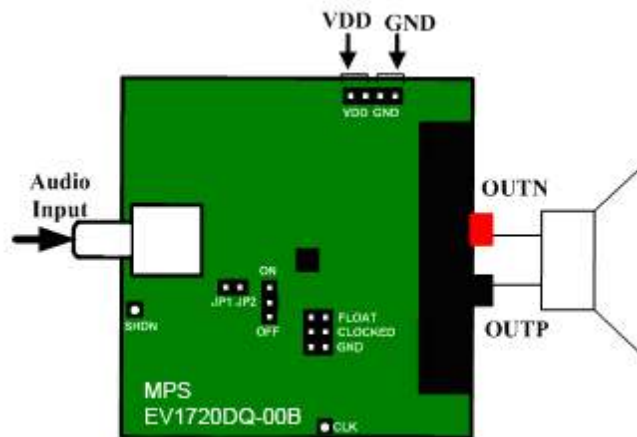

Figure 5—Connection for Mono BTL output (Top viewer)

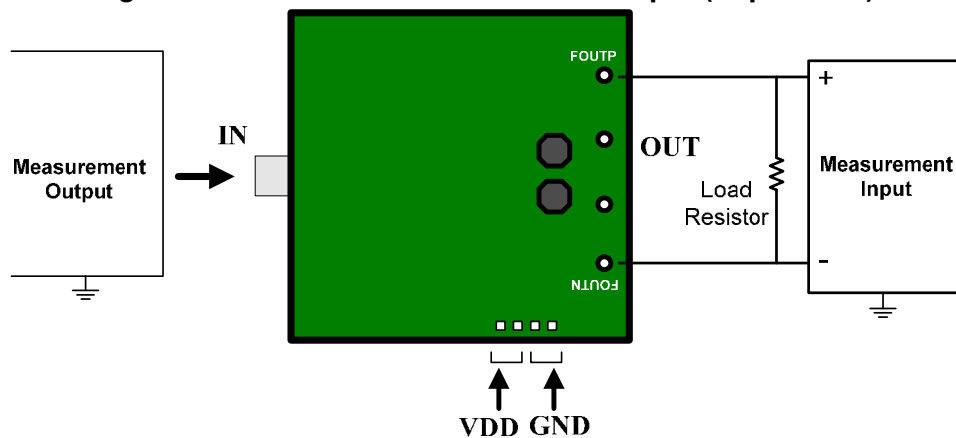

Figure 6—Connection for Audio Performance Test measure (Bottom viewer)

1. Setup Condition for 5V Operation

- a) Ensure that all external power sources are set to off.
- b) Adjust the power supply to 5V (do not turn on).
- c) Connect the power supply to the VDD terminals.
- d) Ensure that the audio input signal source level is set to minimum.
- e) Connect the audio input signal source to the amplifier inputs.
- f) Connect the outputs to the external speakers.

- g) Set the amplifier CLK frequency as the table1: put the jumper to 'GND' to select 1.0MHz frequency; or put the jumper to 'FLOAT' to select 1.3MHz frequency; or put the jumper to 'Clocked' to select external clock frequency and also drive CLK pin with the external TTL clock.
- h) Set the amplifier input configuration: install the jumper JP1 to select SE input, or leave the jumper JP1 open to select differential input.

2. Turn on music

- a) Set the amplifier active station: put the jumper JP2 to 'ON', or leave JP2 open and drive /SHDN pin with the external TTL level logic.
- b) Verify correct voltage and input polarity and turn on the external power supply.
- c) Adjust the input signal source level as needed. Then audio should be heard from the speaker.

Table1—CLK Operating Modes

CLK=GND	$f_{CLK}=1.0\text{MHz}$
CLK=FLOAT	$f_{CLK}=1.3\text{MHz}$
CLK=Clocked	$f_{CLK}=\text{external clock frequency (0.5~1.4MHz)}$

3. Turn off music

- a) Put the jumper JP2 to 'OFF', or drive /SHDN pin with the low-level logic if JP2 is set to open.
- b) Turn off the power supply.

NOTICE: The information in this document is subject to change without notice. Users should warrant and guarantee that third party Intellectual Property rights are not infringed upon when integrating MPS products into any application. MPS will not assume any legal responsibility for any said applications.