

NOTES.

1. MATERIAL : ⓂBRASS, PRE-TIN PLATED
2. FINISH : 0.8~1.8μm,Tin(Sn) plating overall
0.3~0.8μm.Copper(Cu) plating
3. PRODUCT SPECIFICATION : PS-35150-001, PS-35180-002
PS-35180-003, PS-35182-003, PS-35524-001
4. CRIMPING SPECIFICATION : CS-35745-001
5. RECOMMENDED LENGTH OF WIRE STRIP IS 4.0~4.8mm
6. APPLICABLE WIRE SIZE : AWG #20+#20
AWG #20+#18
AWG #18+#18

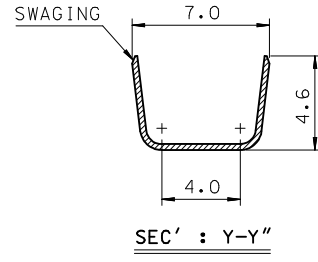
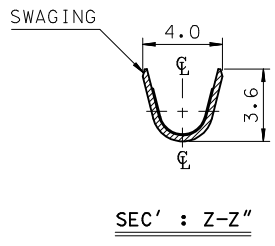
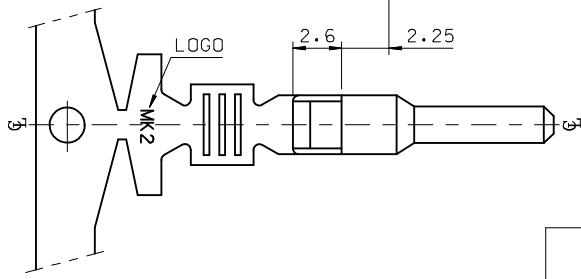
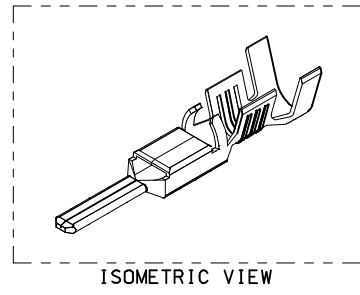
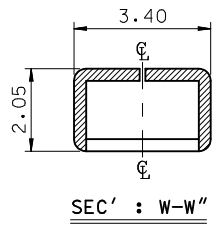
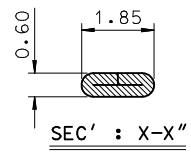
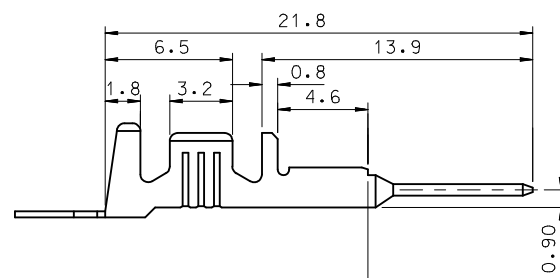
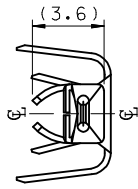
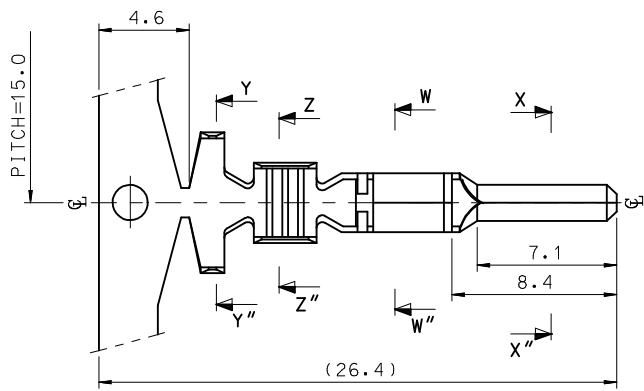

REVISED EC NO: KOR2009-0151 DRWN: JHPARK01 2009/05/18 CHKD: WY. YANG 2009/06/18 APPR: YUNS IKKIM 2009/07/01	DESCRIPTION MK2	QUALITY SYMBOLS	GENERAL TOLERANCES (UNLESS SPECIFIED)		DIMENSION STYLE MM ONLY		SCALE 4:1	DESIGN UNITS METRIC	THIRD ANGLE PROJECTION
		▼=0 ▽=0	mm INCH 4 PLACES ± --- ± --- 3 PLACES ± --- ± --- 2 PLACES ± 0.2 ± --- 1 PLACE ± 0.3 ± --- ANGULAR ± 1°	DRAWN BY JS. KANG	DATE 1998/01/19	TITLE .070 MALE TERMINAL-B (LARGE)			
		DRAFT WHERE APPLICABLE MUST REMAIN WITHIN DIMENSIONS		CHECKED BY BK. CHOI	DATE 1998/01/19	MATERIAL NO. 357470310		DOCUMENT NO. SD-35747-002	SHEET NO. 1 OF 01
				APPROVED BY CW. LEE	DATE 1998/01/19	MATERIAL NO. 357470310		DOCUMENT NO. SD-35747-002	SHEET NO. 1 OF 01