

MAX4376/MAX4377/ MAX4378

Single/Dual/Quad, High-Side Current-Sense Amplifiers with Internal Gain

General Description

The MAX4376/MAX4377/MAX4378 single, dual, and quad precision high-side current-sense amplifiers are available in space-saving packages. They feature buffered voltage outputs that eliminate the need for gain-setting resistors and are ideal for today's notebook computers, cell phones, and other systems where current monitoring is critical. These precision devices are offered in three fixed-gain versions of 20, 50, and 100:

GAIN	SUFFIX
20	T
50	F
100	H

For example, MAX4376TAUK is a single high-side amplifier with a gain of 20.

High-side current monitoring is especially useful in battery-powered systems since it does not interfere with the ground path of the battery charger. The input common-mode range of 0 to +28V is independent of the supply voltage and ensures that the current-sense feedback remains viable even when connected to a battery pack in deep discharge.

The full-scale current reading can be set by choosing the appropriate voltage gain and external-sense resistor. This capability offers a high level of integration and flexibility, resulting in a simple and compact current-sense solution. The MAX4376/MAX4377/MAX4378 operate over a supply voltage range of +3V to +28V, draw 1mA of supply current per amplifier, and operate over the full automotive temperature range of -40°C to +125°C. These devices have a wide bandwidth of 2MHz, making them suitable for use inside battery-charger control loops. The buffered outputs drive up to 2mA of output current into a ground-referenced load. The MAX4376 is available in a tiny 5-pin SOT23 package. The MAX4377/MAX4378 are available in space-saving 8-pin μ MAX[®] and 14-pin TSSOP packages, respectively.

Typical Operating Circuit

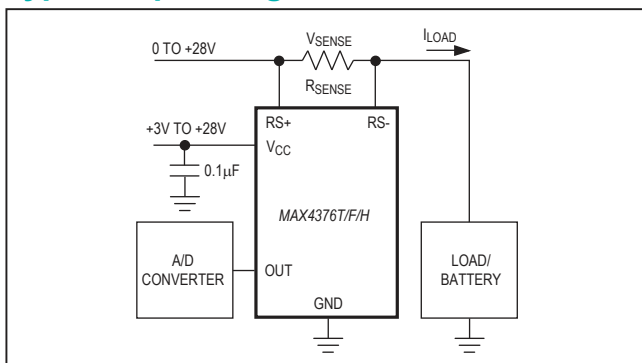

Features

- Low-Cost, Single/Dual/Quad, High-Side Current-Sense Amplifiers
- $\pm 0.5\%$ Typical Full-Scale Accuracy
- +3V to +28V Supply Operation
- Adjustable Current-Sense Capability with External Sense Resistor
- Buffered Output Voltage with 2mA Drive
- 1mA (typ) Supply Current
- 2.0MHz Bandwidth (Gain = +20V/V)
- Automotive Temperature Range (-40°C to +125°C)
- High Accuracy +2V to +28V Common-Mode Range, Functional Down to 0V, Independent of Supply Voltage
- Three Gain Versions Available
 - +20V/V (MAX437_T)
 - +50V/V (MAX437_F)
 - +100V/V (MAX437_H)
- Available in Space-Saving 5-Pin SOT23 (Single), 8-Pin μ MAX (Dual), and 14-Pin TSSOP (Quad)
- AEC-Q100 Qualified, Refer to Ordering Information for the List of /V Parts

Applications

- Notebook Computers
- Current-Limited Power Supplies
- Fuel Gauges in PC
- General-System/Board-Level Current Monitoring
- Battery Chargers
- Portable/Battery-Powered Systems
- Cell Phones
- Smart Battery Packages
- Automotive Current Detect
- Power Management Systems
- PA Bias Control
- Automotive

μ MAX is a registered trademark of Maxim Integrated Products, Inc.

Absolute Maximum Ratings

V _{CC} , RS+, RS- to GND	-0.3V to +30V	8-Pin SO (derate 5.88mW/°C above +70°C).....	471mW
OUT to GND	-0.3V to (V _{CC} + 0.3V)	14-Pin SO (derate 8.33mW/°C above +70°C).....	667mW
Differential Input Voltage (V _{RS+} - V _{RS-})	±8V	14-Pin TSSOP (derate 9.1mW/°C above +70°C).....	727mW
Output Short Circuit to V _{CC}	Continuous	Operating Temperature Range	-40°C to +125°C
Output Short Circuit to GND.....	1s	Junction Temperature	+150°C
Current into Any Pin	±20mA	Storage Temperature Range	-65°C to +150°C
Continuous Power Dissipation (T _A = +70°C)		Lead Temperature (soldering, 10s)	+300°C
5-Pin SOT23 (derate 3.10mW/°C above +70°C) ...	246.70mW	Soldering Temperature (reflow)	+260°C
8-Pin μMAX (derate 4.5mW/°C above +70°C).....	362mW		

Stresses beyond those listed under "Absolute Maximum Ratings" may cause permanent damage to the device. These are stress ratings only, and functional operation of the device at these or any other conditions beyond those indicated in the operational sections of the specifications is not implied. Exposure to absolute maximum rating conditions for extended periods may affect device reliability.

Package Information

5 SOT23

PACKAGE CODE	U5+2, U5+2A
Outline Number	21-0057
Land Pattern Number	90-0174
Thermal Resistance, Multi-Layer Board:	
Junction to Ambient (θ _{JA})	255.90°C/W
Junction to Case (θ _{JC})	81°C/W

For the latest package outline information and land patterns (footprints), go to www.maximintegrated.com/packages. Note that a "+", "#", or "-" in the package code indicates RoHS status only. Package drawings may show a different suffix character, but the drawing pertains to the package regardless of RoHS status.

Package thermal resistances were obtained using the method described in JEDEC specification JESD51-7, using a four-layer board. For detailed information on package thermal considerations, refer to www.maximintegrated.com/thermal-tutorial.

Electrical Characteristics

($V_{RS+} = 0$ to 28V, $V_{SENSE} = (V_{RS+} - V_{RS-}) = 0V$, $V_{CC} = +3.0V$ to +28V, $R_L = \infty$, $T_A = T_{MIN}$ to T_{MAX} , unless otherwise noted. Typical values are at $T_A = +25^\circ C$.) (Note 1)

PARAMETER	SYMBOL	CONDITIONS		MIN	TYP	MAX	UNITS
Operating Voltage Range	V_{CC}	Guaranteed by PSR test		3		28	V
Common-Mode Input Range	V_{CM}	Guaranteed by total OUT voltage error test		0		28	V
Common-Mode Rejection	CMR	$2V \leq V_{RS+} \leq 28V$, $V_{SENSE} = 100mV$			90		dB
Supply Current per Amplifier	I_{CC}	$V_{SENSE} = 5mV$, $V_{RS+} > 2.0V$, $V_{CC} = 12V$			1	2.2	mA
Leakage Current	I_{RS+} , I_{RS-}	$V_{CC} = 0V$, $V_{RS+} = 28V$				8	μA
Input Bias Current	I_{RS+}	$V_{RS+} > 2.0V$		0		60	μA
		$V_{RS+} \leq 2.0V$		-400		+60	
	I_{RS-}	$V_{RS+} > 2.0V$		0		120	
		$V_{RS+} \leq 2.0V$		-800		+120	
Full-Scale Sense Voltage	V_{SENSE}				150		mV
Total OUT Voltage Error (Note 2)		$I_{OUT} \leq 2mA$	$V_{SENSE} = 100mV$, $V_{CC} = 12V$, $V_{RS+} = 12V$			± 6.75	%
			$V_{SENSE} = 100mV$, $V_{CC} = 12V$, $T_A = +25^\circ C$, $V_{RS+} = 12V$		± 0.5	± 3.25	
			$V_{SENSE} = 100mV$, $V_{CC} = 28V$, $V_{RS+} = 28V$			± 11	
			$V_{SENSE} = 100mV$, $V_{CC} = 28V$, $V_{RS+} = 28V$, $T_A = +25^\circ C$		± 0.5	± 5	
			$V_{SENSE} = 100mV$, $V_{CC} = 12V$, $V_{RS+} = 0.1V$		± 9	± 32	
			$V_{SENSE} = 6.25mV$, $V_{CC} = 12V$, $V_{RS+} = 12V$ (Note 3)		± 7		
OUT High Voltage (Note 4)	$(V_{CC} - V_{OUT})$	$V_{CC} = 3V$, $I_{OUT} = 2mA$, $V_{RS+} = 28V$			0.9	1.2	V
OUT Low Voltage	V_{OL}	$I_{OUT} = 200\mu A$, $V_{CC} = V_{RS+} = 12V$, $V_{SENSE} = 0V$, $T_A = +25^\circ C$			25	40	mV

Electrical Characteristics (continued)

($V_{RS+} = 0$ to 28V, $V_{SENSE} = (V_{RS+} - V_{RS-}) = 0V$, $V_{CC} = +3.0V$ to +28V, $R_L = \infty$, $T_A = T_{MIN}$ to T_{MAX} , unless otherwise noted. Typical values are at $T_A = +25^\circ C$.) (Note 1)

PARAMETER	SYMBOL	CONDITIONS		MIN	TYP	MAX	UNITS
Bandwidth	BW	$V_{CC} = 12V$ $V_{RS+} = 12V$ $V_{SENSE} = 15pF$	$V_{SENSE} = 100mV$ (gain = +20V/V)		2		MHz
			$V_{SENSE} = 100mV$ (gain = +50V/V)		1.7		
			$V_{SENSE} = 100mV$ (gain = +100V/V)		1.2		
			$V_{SENSE} = 6.25mV$ (Note 3)		0.5		
Slew Rate	SR	$V_{SENSE} = 20mV$ to 100mV, $C_{LOAD} = 15pF$			10		V/ μs
Gain	AV	MAX437_T			+20		V/V
		MAX437_F			+50		
		MAX437_H			+100		
Gain Accuracy	ΔAV	$V_{SENSE} = 10mV$ to 150mV, $V_{CC} = 12V$, $I_{OUT} = 2mA$, gain = 20 and 50, $V_{RS+} = 12V$	$T_A = T_{MIN}$ to T_{MAX}			± 5.5	%
			$T_A = +25^\circ C$		± 0.5	± 2.5	
		$V_{SENSE} = 10mV$ to 150mV, $V_{CC} = 20V$, $I_{OUT} = 2mA$, gain = 100, $V_{RS+} = 12V$	$T_A = T_{MIN}$ to T_{MAX}			5.5	
			$T_A = +25^\circ C$		± 0.5	± 2.5	
OUT Setting Time to 1% of Final Value		$V_{CC} = 12V$, $V_{RS+} = 12V$, $C_{LOAD} = 15pF$	$V_{SENSE} = 6.25mV$ to 100mV		400		ns
			$V_{SENSE} = 100mV$ to 6.25mV		800		
Maximum Capacitive Load	CLOAD	No sustained oscillation			1000		pF
Output Resistance	ROUT	$V_{SENSE} = 100mV$			5		Ω
Power-Supply Rejection	PSR	$V_{RS+} > 2V$, $V_{OUT} = 1.6V$, $V_{CC} = 3V$ to 28V		66	90		dB
Power-Up Time to 1% of Final Value		$V_{SENSE} = 100mV$, $C_{LOAD} = 15pF$			2		μs
Saturation Recovery Time to 1% of Final Value		$V_{CC} = 12V$, $V_{RS+} = 12V$, $C_{LOAD} = 15pF$, $V_{SENSE} = 100mV$			1		μs
Reverse Recovery Time to 1% of Final Value		$V_{CC} = 12V$, $V_{RS-} = 12V$, $C_{LOAD} = 15pF$, $V_{SENSE} = -100mV$ to +100mV			1		μs

Note 1: All devices are 100% production tested at $T_A = +25^\circ C$. All temperature limits are guaranteed by design.

Note 2: Total OUT Voltage Error is the sum of gain and offset errors.

Note 3: 6.25mV = 1/16 of 100mV full-scale sense voltage.

Note 4: V_{SENSE} such that V_{OUT} is in saturation.

MAX4376/MAX4377/ MAX4378

Single/Dual/Quad, High-Side Current-Sense Amplifiers with Internal Gain

Typical Operating Characteristics

($V_{CC} = V_{RS+} = 12V$, $V_{SENSE} = 100mV$, $T_A = +25^{\circ}C$.)

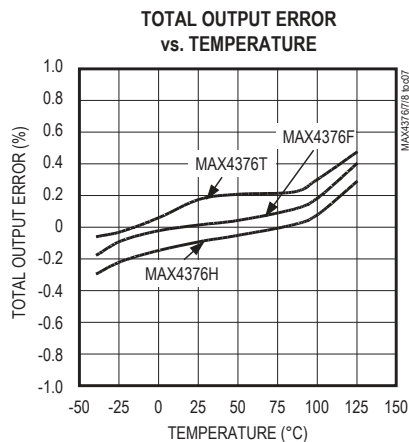
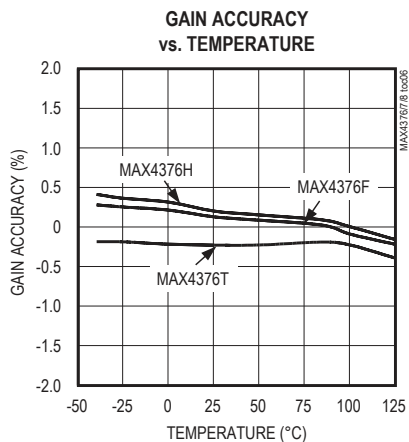
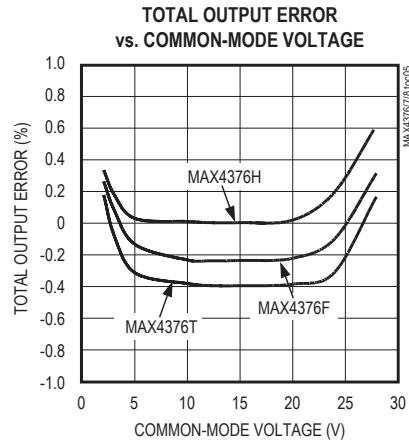
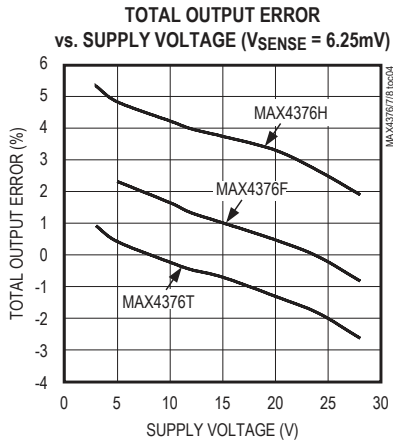
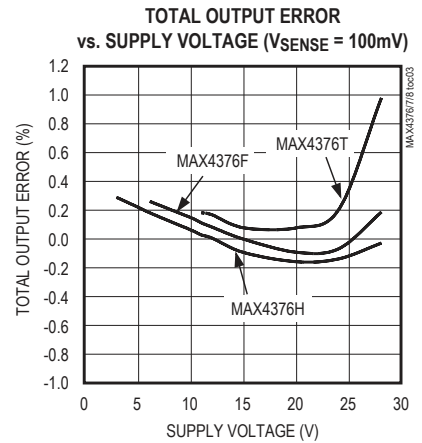
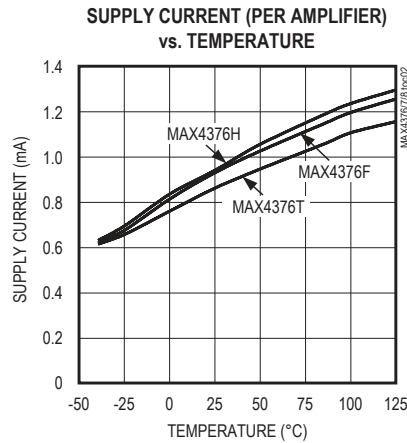
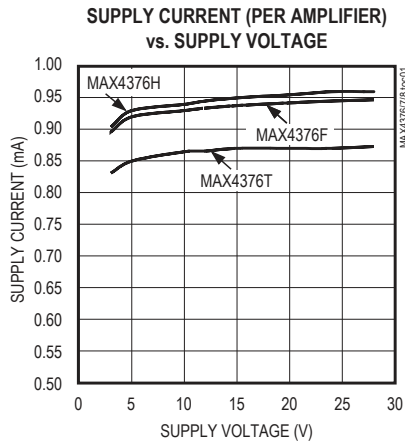

MAX4376/MAX4377/
MAX4378

Single/Dual/Quad, High-Side
Current-Sense Amplifiers with Internal Gain

Typical Operating Characteristics (continued)

($V_{CC} = V_{RS+} = 12V$, $V_{SENSE} = 100mV$, $T_A = +25^{\circ}C$.)

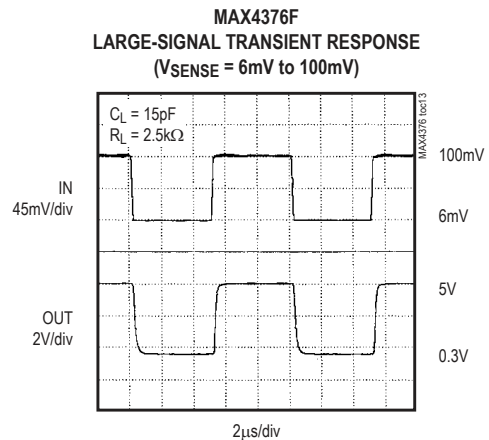
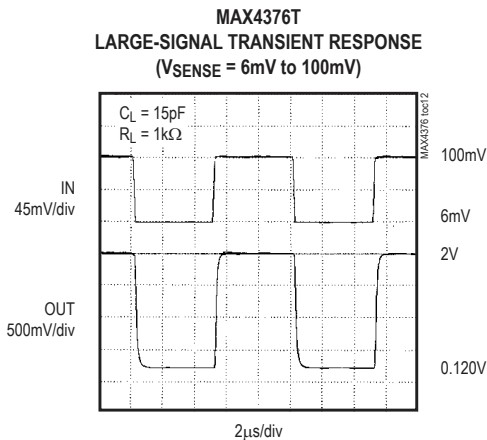
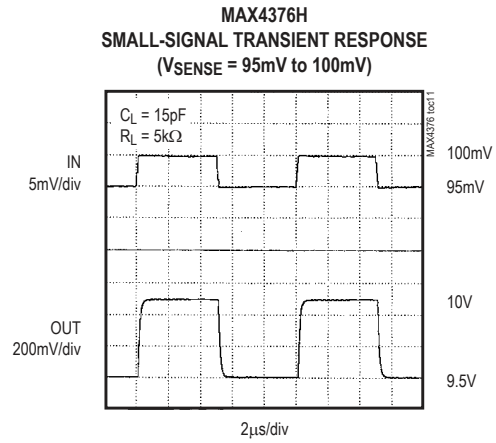
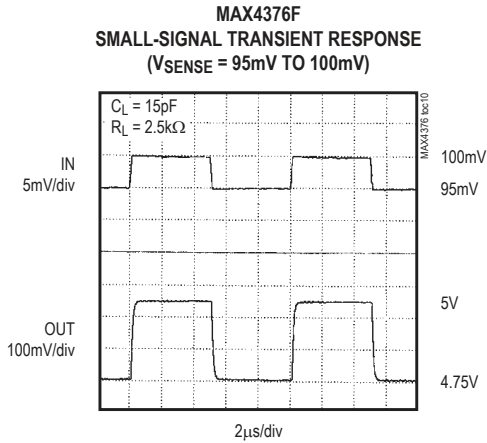
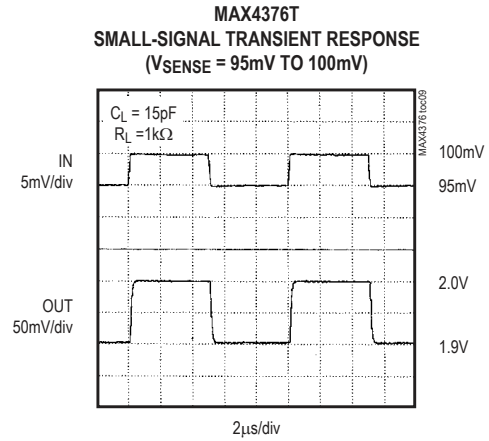
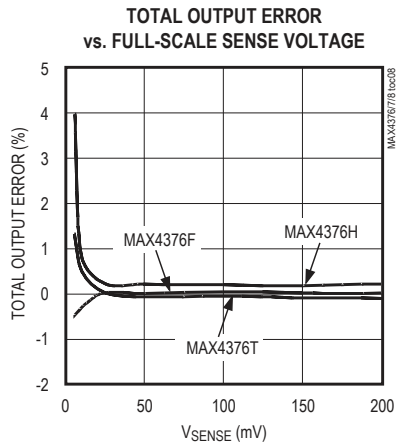

MAX4376/MAX4377/
MAX4378

Single/Dual/Quad, High-Side
Current-Sense Amplifiers with Internal Gain

Typical Operating Characteristics (continued)

($V_{CC} = V_{RS+} = 12V$, $V_{SENSE} = 100mV$, $T_A = +25^{\circ}C$.)

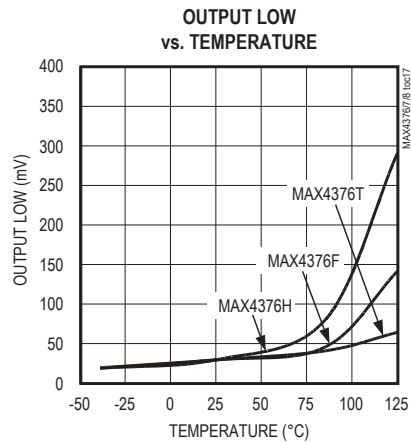
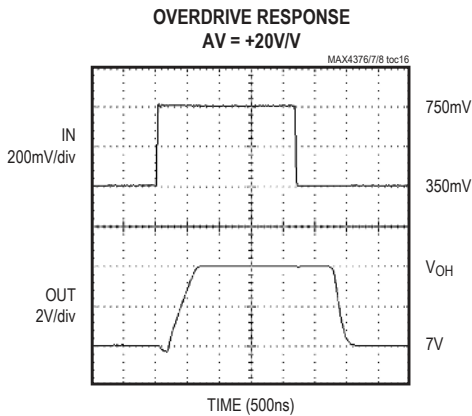
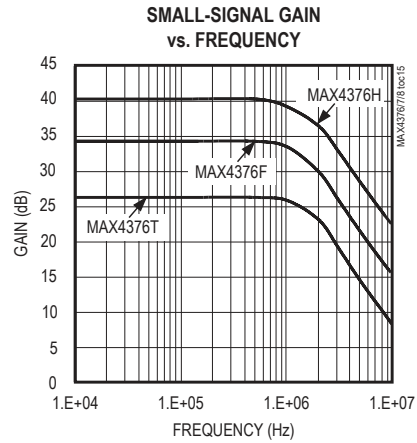
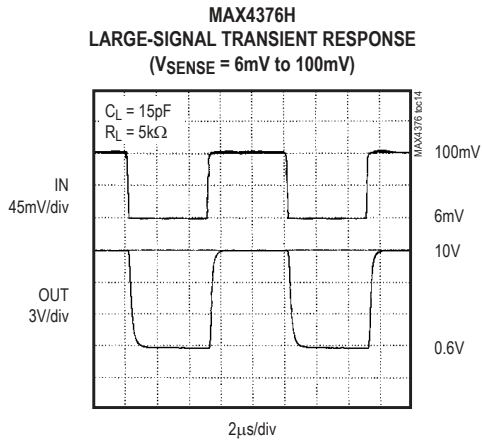

MAX4376/MAX4377/
MAX4378

Single/Dual/Quad, High-Side
Current-Sense Amplifiers with Internal Gain

Pin Configurations

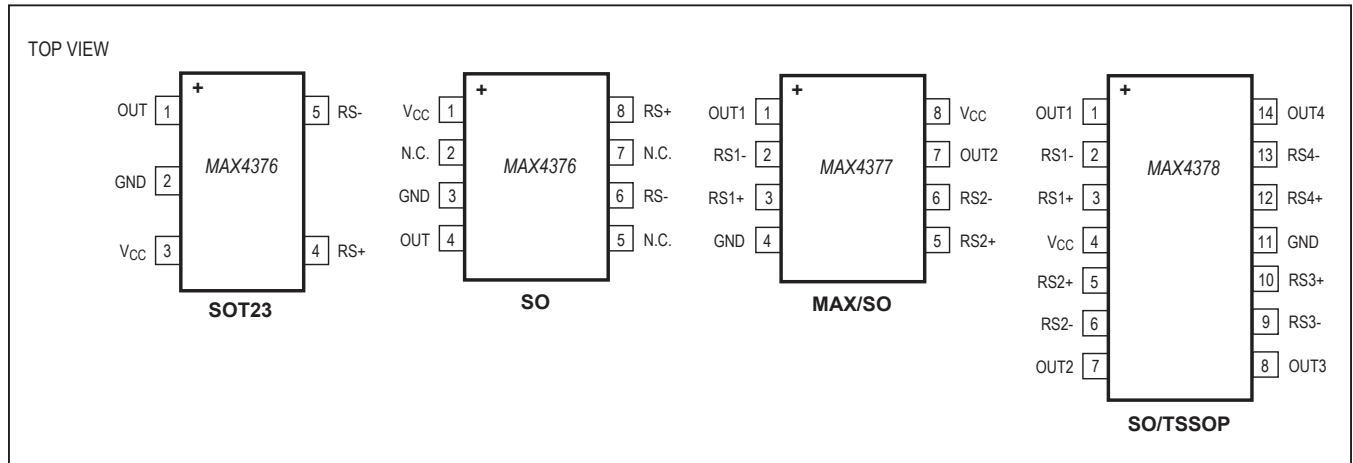

Pin Descriptions

PIN				NAME	FUNCTION
MAX4376	MAX4376	MAX4377	MAX4378		
SOT23-5	SO-8	MMAX-8/ SO-8	SO-14/ TSSOP-14		
1	4	1, 7	1, 7, 8, 14	OUT, OUT ₋	Output Voltage. VOUT ₋ is proportional to the magnitude of the sense voltage (VRS ₊ - VRS ₋). VOUT ₋ is approximately zero when VRS ₋ > VRS ₊ (no phase reversal).
2	3	4	11	GND	Ground
3	1	8	4	VCC	Supply Voltage
4	8	3, 5	3, 5, 10, 12	RS ₊ , RS ₊	Power connection to the external sense resistor
5	6	2, 6	2, 6, 9, 13	RS ₋ , RS ₋	Load-side connection to the external sense resistor
—	2, 5, 7	—	—	N.C.	No Connection. Not internally connected.

Detailed Description

The MAX4376/MAX4377/MAX4378 high-side current-sense amplifiers feature a 0 to +28V input common-mode range that is independent of supply voltage. This feature allows the monitoring of current out of a battery in deep discharge and also enables high-side current sensing at voltages greater than the supply voltage (V_{CC}).

The MAX4376/MAX4377/MAX4378 operate as follows: current from the source flows through R_{SENSE} to the load (Figure 1). Since the internal sense amplifier's inverting input has high impedance, negligible current flows through R_{G2} (neglecting the input bias current). Therefore, the sense amplifier's inverting-input voltage equals $V_{SOURCE} - (I_{LOAD})(R_{SENSE})$.

The amplifier's open-loop gain forces its noninverting input to the same voltage as the inverting input. Therefore, the drop across R_{G1} equals $(I_{LOAD})(R_{SENSE})$. Since I_{RG1} flows through R_{G1} , $I_{RG1} = (I_{LOAD})(R_{SENSE})/R_{G1}$. The internal current mirror multiplies I_{RG1} by a current gain factor, β , to give $I_{RGD} = \beta \times I_{RG1}$. Solving $I_{RGD} = \beta \times (I_{LOAD})(R_{SENSE})/R_{G1}$.

Therefore:

$$V_{OUT} = b \times (R_{GD}/R_{G1})(R_{SENSE} \times I_{LOAD}) \times \text{amp gain}$$

where amp gain is 2, 5, or 10.

The part's gain equals $(\beta \times R_{GD} / R_{G1}) \times \text{amp gain}$.

Therefore:

$$V_{OUT} = (\text{GAIN})(R_{SENSE})(I_{LOAD})$$

where GAIN = 20 for MAX437_T.

GAIN = 50 for MAX437_F.

GAIN = 100 for MAX437_H.

Set the full-scale output range by selecting R_{SENSE} and the appropriate gain version of the MAX4376/ MAX4377/ MAX4378.

Applications Information

Recommended Component Values

The MAX4376/MAX4377/MAX4378 sense a wide variety of currents with different sense resistor values. Table 1 lists common resistor values for typical operation of the MAX4376/MAX4377/MAX4378.

Choosing R_{SENSE}

To measure lower currents more accurately, use a high value for R_{SENSE} . The high value develops a higher sense voltage that reduces offset voltage errors of the internal op amp.

In applications monitoring very high currents, R_{SENSE} must be able to dissipate the I^2R losses. If the resistor's rated power dissipation is exceeded, its value may drift or it may fail altogether, causing a differential voltage across the terminals in excess of the absolute maximum ratings.

If I_{SENSE} has a large high-frequency component, minimize the inductance of R_{SENSE} . Wire-wound resistors have the highest inductance, metal-film resistors are somewhat better, and low-inductance metal-film resistors are best suited for these applications.

Bidirectional Current-Sense Amplifier

Systems such as laptop computers and other devices that have internal charge circuitry require a precise bidirectional current-sense amplifier to monitor accurately the battery's current regardless of polarity. Figure 2 shows the MAX4377 used as a bidirectional current monitor. This is useful for implementing either smart battery packs or fuel gauges.

Current Source Circuit

Figure 3 shows a block diagram using the MAX4376 with a switching regulator to make a current source.

Table 1. Recommended Component Values

FULL-SCALE LOAD CURRENT, I_{LOAD} (A)	CURRENT-SENSE RESISTOR, R_{SENSE} (m Ω)	GAIN (+V/V)	FULL-SCALE OUTPUT VOLTAGE (FULL-SCALE $V_{SENSE} = 100\text{mV}$), V_{OUT} (V)
0.1	1000	20	2.0
		50	5.0
		100	10.0
1	100	20	2.0
		50	5.0
		100	10.0
5	20	20	2.0
		50	5.0
		100	10.0
10	10	20	2.0
		50	5.0
		100	10.0

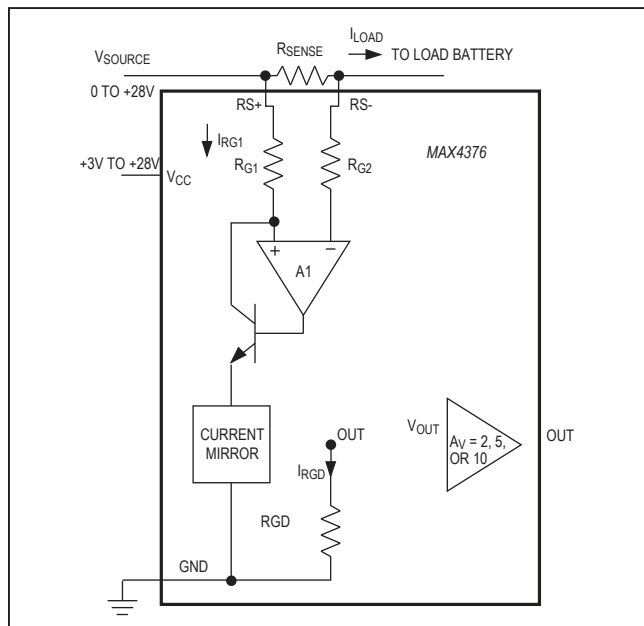

Figure 1. Functional Diagram

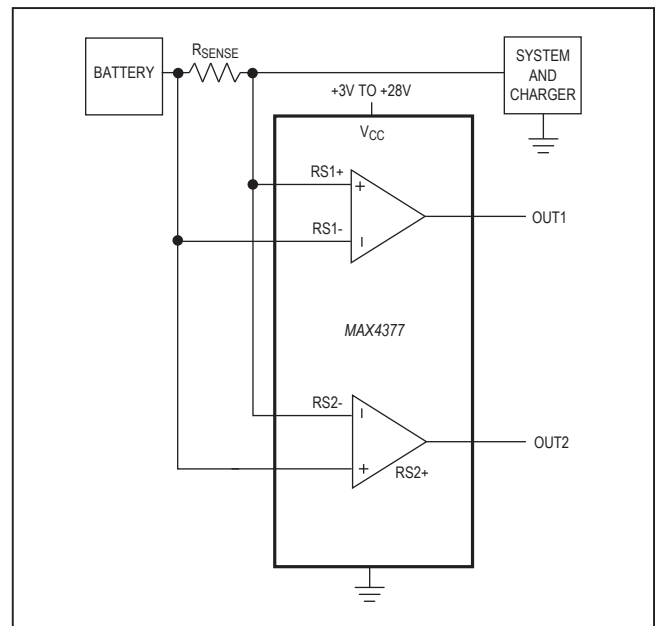

Figure 2. Bidirectional Current Monitor

MAX4376/MAX4377/
MAX4378

Single/Dual/Quad, High-Side
Current-Sense Amplifiers with Internal Gain

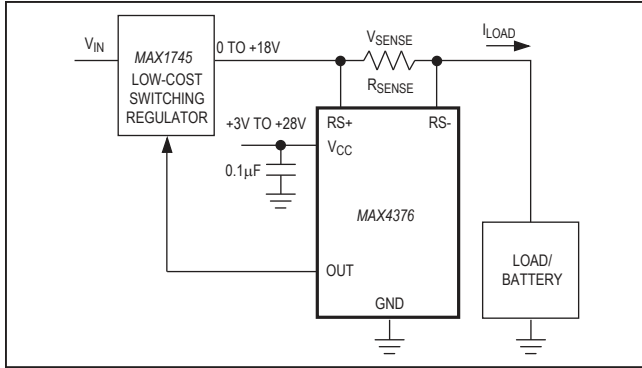

Figure 3. Current Source

Chip Information

PROCESS: BiCMOS

Ordering Information

PART	GAIN (+V/V)	TEMP ANGE	PIN-PACKAGE	TOP MARK
MAX4376TAUK+T	20	-40°C to +125°C	5 SOT23	ADOG
MAX4376TAUK/V+T	20	-40°C to +125°C	5 SOT23	AMGC
MAX4376FAUK+T	50	-40°C to +125°C	5 SOT23	ADOH
MAX4376FAUK/V+T	50	-40°C to +125°C	5 SOT23	AMJI
MAX4376HAUK+T	100	-40°C to +125°C	5 SOT23	ADOI
MAX4376HAUK/V+T	100	-40°C to +125°C	5 SOT23	AFGO
MAX4376TASA+	20	-40°C to +125°C	8 SO	—
MAX4376FASA+	50	-40°C to +125°C	8 SO	—
MAX4376HASA+	100	-40°C to +125°C	8 SO	—
MAX4377TAUA+	20	-40°C to +125°C	8 µMAX	—
MAX4377FAUA+	50	-40°C to +125°C	8 µMAX	—
MAX4377HAUA+	100	-40°C to +125°C	8 µMAX	—
MAX4377TASA+	20	-40°C to +125°C	8 SO	—
MAX4377FASA+	50	-40°C to +125°C	8 SO	—
MAX4377HASA+	100	-40°C to +125°C	8 SO	—
MAX4378TAUD+	20	-40°C to +125°C	14 TSSOP	—
MAX4378FAUD+	50	-40°C to +125°C	14 TSSOP	—
MAX4378HAUD+	100	-40°C to +125°C	14 TSSOP	—
MAX4378TASD+	20	-40°C to +125°C	14 SO	—
MAX4378FASD+	50	-40°C to +125°C	14 SO	—
MAX4378HASD+	100	-40°C to +125°C	14 SO	—

+Denotes a lead (Pb)-free/RoHS-compliant package.

/V denotes an automotive qualified part.

T = Tape and reel.

MAX4376/MAX4377/
MAX4378

Single/Dual/Quad, High-Side
Current-Sense Amplifiers with Internal Gain

Package Information

For the latest package outline information and land patterns (footprints), go to www.maximintegrated.com/packages. Note that a "+", "#", or "-" in the package code indicates RoHS status only. Package drawings may show a different suffix character, but the drawing pertains to the package regardless of RoHS status.

PACKAGETYPE	PACKAGE CODE	OUTLINE NO.	LAND PATTERN NO.
8 SOIC	S8+2	21-0041	90-0096
8 μ MAX	U8+1	21-0036	90-0092
14 SOIC	S14+1	21-0041	90-0096
14 TSSOP	U14+1	21-0066	90-0117

Revision History

REVISION NUMBER	REVISION DATE	DESCRIPTION	PAGES CHANGED
4	4/09	Added automotive part number and lead-free designations	1, 9
5	6/10	Clarified 0V to 2V is not a high-accuracy range for the device, added soldering temperature and <i>Package Information</i> section	1, 2, 10
6	2/11	Specified VRS+ value	2, 3
7	10/12	Added MAX4376HASA+ and MAX4376TAUK/V+T to <i>Ordering Information</i>	1
8	4/18	Updated <i>Ordering Information</i> table and <i>Features</i> section	1
9	7/18	Updated <i>Features</i> section, <i>Pin Configuration</i> diagram, and <i>Ordering Information</i> table	1, 9
10	7/18	Updated <i>Package Information</i> table	11
11	8/18	Updated <i>Package Information</i> table	11
12	12/18	Updated package code	2
13	11/19	Updated <i>Package Information</i>	2

For pricing, delivery, and ordering information, please visit Maxim Integrated's online storefront at <https://www.maximintegrated.com/en/storefront/storefront.html>.

Maxim Integrated cannot assume responsibility for use of any circuitry other than circuitry entirely embodied in a Maxim Integrated product. No circuit patent licenses are implied. Maxim Integrated reserves the right to change the circuitry and specifications without notice at any time. The parametric values (min and max limits) shown in the Electrical Characteristics table are guaranteed. Other parametric values quoted in this data sheet are provided for guidance.