

THIS DRAWING IS UNPUBLISHED. RELEASED FOR PUBLICATION
 © COPYRIGHT - By - ALL RIGHTS RESERVED.

REVISIONS				
P	LTR	DESCRIPTION	DATE	APVD
B2		REVISED PER ECR-16-014022	06OCT2016	BW RS

- 1 CONTINUOUS STRIP ON REELS WITH TERMINALS LOCATED ON 11.13 ± 0.13 [.438 ± .005] CENTERS.
- 2 SUFFIX LETTER MUST BE USED ONLY WHEN ORDERING APPLICATOR TOOLING.
- 3 APPLICATOR TOOLING PRESENTLY AVAILABLE FOR BENT VERSION ONLY.
- 4 CONTACT WIDTH MUST BE SPECIFIED WHEN ORDERING APPLICATOR.
- 5 0.002032 [.000080] MIN TIN PLATE.

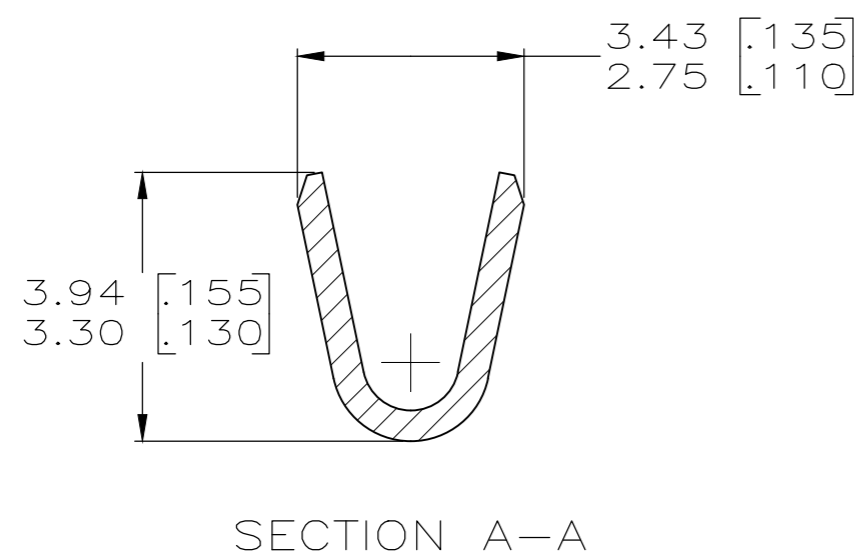
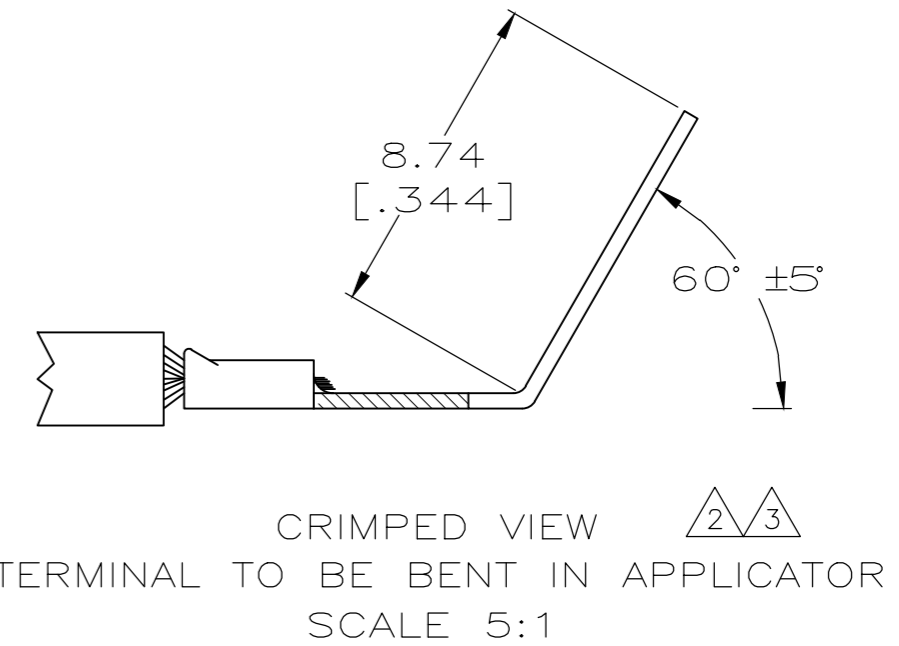
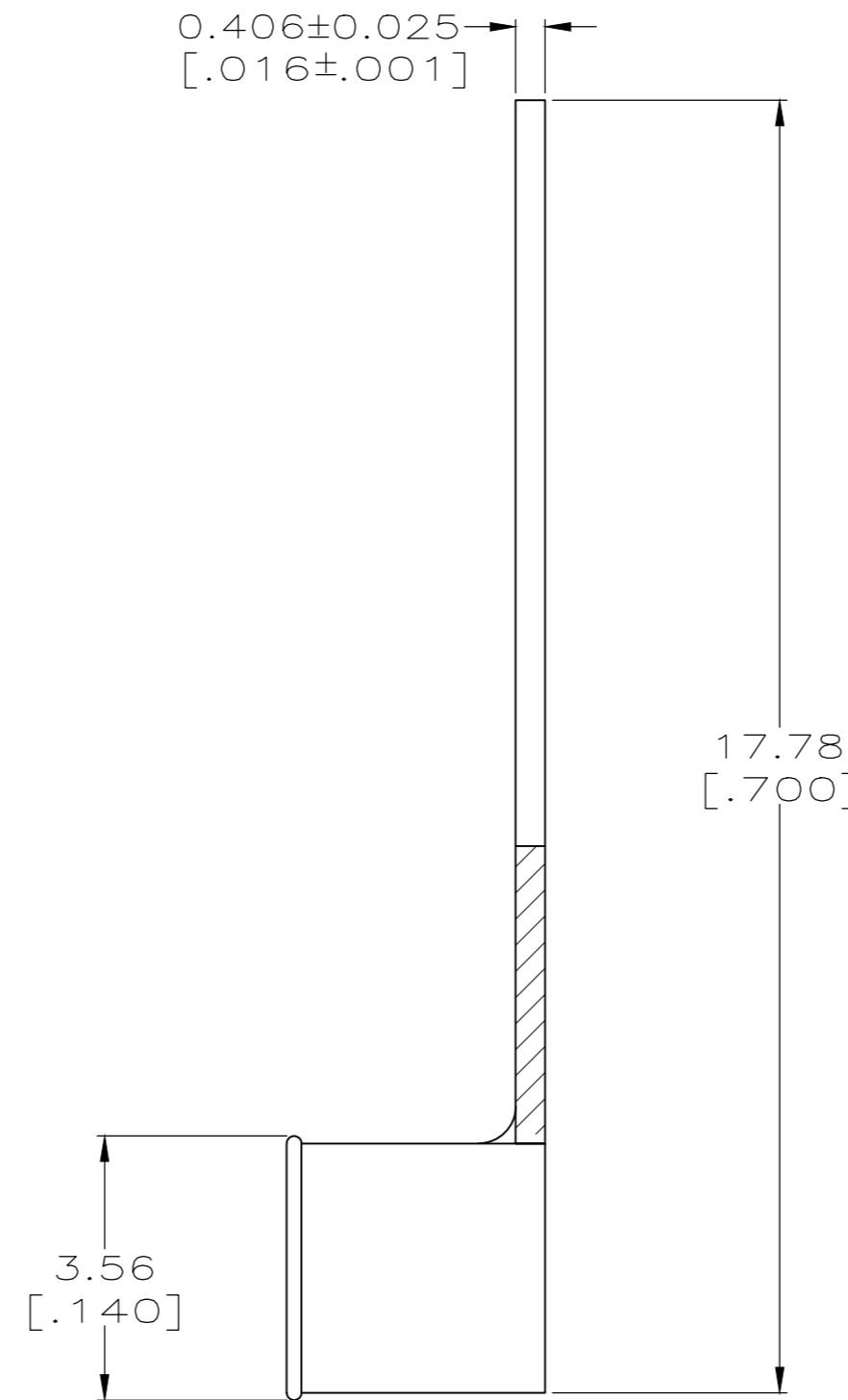
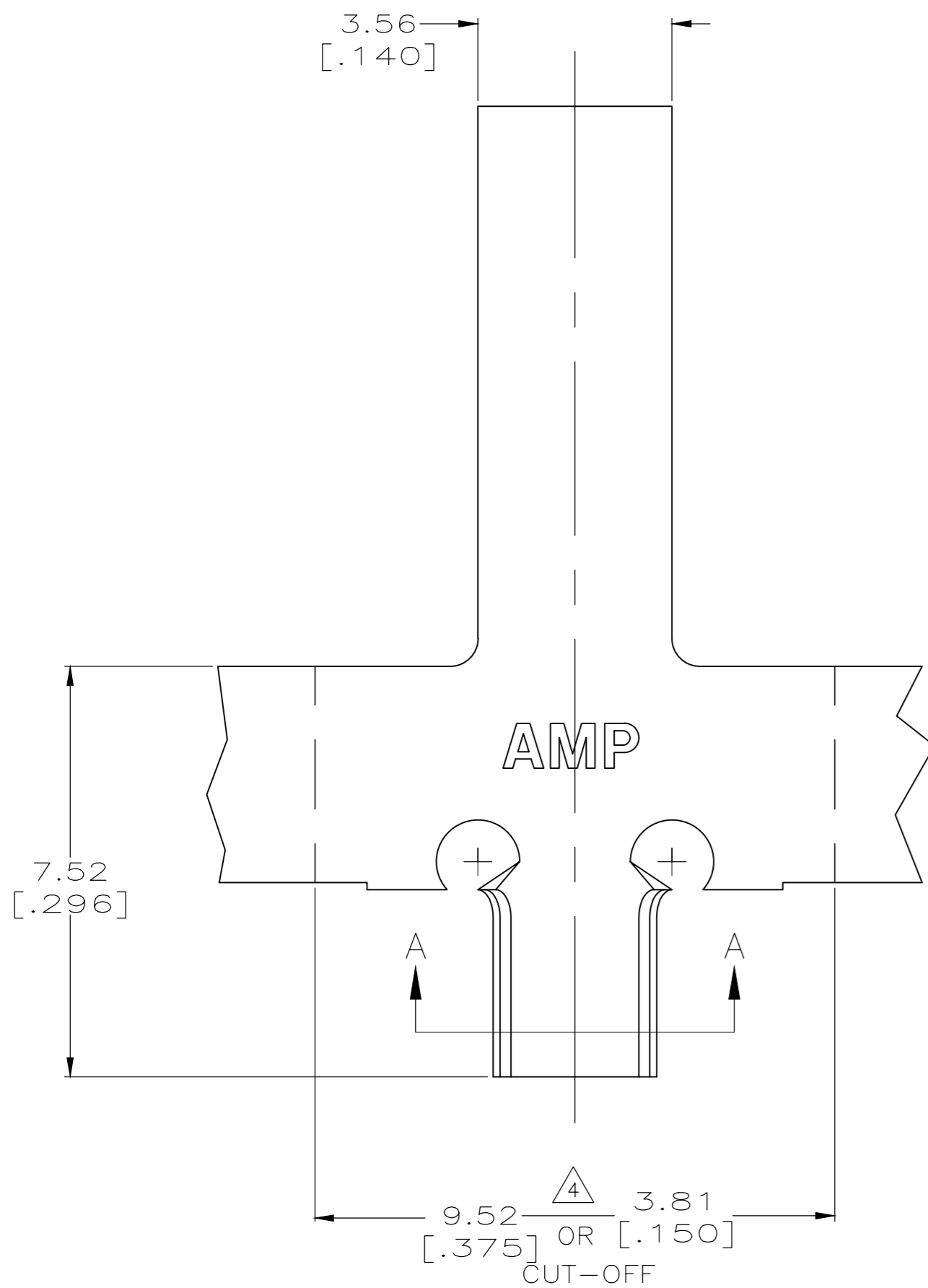

OBSOLETE	5	42349-2 H	#18-#14 OR (2) #18	42349-2
NONE	2	42349-1 H	#18-#14 OR (2) #18	42349-1
FINISH		TERMINAL NUMBER BENT	WIRE RANGE	PART NUMBER
THIS DRAWING IS A CONTROLLED DOCUMENT.		DWN SCOTT URICH 12AUG98	TE TE Connectivity	
DIMENSIONS: mm [INCHES]		CHK MICHAEL S. FEHER 22SEP98		
TOLERANCES UNLESS OTHERWISE SPECIFIED:		APVD DON DECKER 23SEP98	NAME CONTACT, LAMP	
0 PLC ± -		PRODUCT SPEC	-	
1 PLC ± -		APPLICATION SPEC	-	
2 PLC ± -		WEIGHT 0	SIZE A2	CAGE CODE 00779
3 PLC ± 0.25 [.010]		FINISH SEE TABLE	DRAWING NO C=42349	RESTRICTED TO -
4 PLC ± -		CUSTOMER DRAWING	SCALE 10:1	SHEET 1 of 1
ANGLES ± -			REV B2	