

CIRCUIT SIZE	DIM. "A"	DIM. "B"	DIM. "C"
2	$\frac{.21}{(5.4)}$	—	$\frac{.370}{(9.40)}$
4	$\frac{.38}{(9.6)}$	$\frac{.17}{(4.2)}$	$\frac{.535}{(13.60)}$
6	$\frac{.54}{(13.8)}$	$\frac{.33}{(8.4)}$	$\frac{.701}{(17.80)}$
8	$\frac{.71}{(18.0)}$	$\frac{.50}{(12.6)}$	$\frac{.866}{(22.00)}$
10	$\frac{.87}{(22.2)}$	$\frac{.66}{(16.8)}$	$\frac{1.031}{(26.20)}$
12	$\frac{1.04}{(26.4)}$	$\frac{.83}{(21.0)}$	$\frac{1.197}{(30.40)}$
14	$\frac{1.20}{(30.6)}$	$\frac{.99}{(25.2)}$	$\frac{1.362}{(34.60)}$
16	$\frac{1.37}{(34.8)}$	$\frac{1.16}{(29.4)}$	$\frac{1.528}{(38.80)}$
18	$\frac{1.54}{(39.0)}$	$\frac{1.32}{(33.6)}$	$\frac{1.693}{(43.00)}$
20	$\frac{1.70}{(43.2)}$	$\frac{1.49}{(37.8)}$	$\frac{1.858}{(47.20)}$
22	$\frac{1.87}{(47.4)}$	$\frac{1.65}{(42.0)}$	$\frac{2.024}{(51.40)}$
24	$\frac{2.03}{(51.6)}$	$\frac{1.82}{(46.2)}$	$\frac{2.189}{(55.60)}$

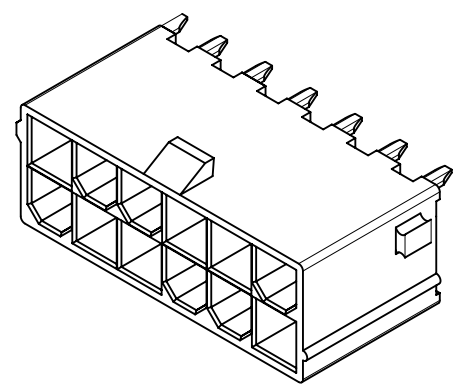

12 CKT SHOWN

- NOTES:
- MATERIALS:  
HOUSING MATERIAL AND OPTIONS: SEE CHART  
TERMINALS: BRASS
  - TERMINAL PLATING:  
A = .000035/(0.00089) MIN. REFLOWED MATTE TIN OVER  
.000020/(0.00051) MIN. COPPER OVERALL (PREPLATE)  
(FINISH IS BRIGHT IN APPEARANCE, THICKNESS AS APPLIED PRIOR TO REFLOW)  
B = .000030/(0.00076) MIN. SELECT GOLD AND  
.000100/(0.00254) MIN. MATTE TIN OVER  
.000050/(0.00127) MIN. NICKEL OVERALL  
C = .000100/(0.00254) MIN. BRIGHT TIN OVER  
.000050/(0.00127) MIN. NICKEL OVERALL  
D = .000100/(0.00254) MIN. MATTE TIN OVER  
.000050/(0.00127) MIN. NICKEL OVERALL
  - PRODUCT SPECIFICATION: PS-5556-001
  - PACKAGING: SEE CHART.
  - PART MATES WITH MINI-FIT JR. RECEPTACLE #5557.
  - PARTS ARE NOT DESIGNED FOR CURRENT SHARING.
  - CONNECTOR ASSEMBLIES ARE NOT DESIGNED TO BE MATED OR UNMATED WHILE CIRCUITS ARE LIVE.
  - LOCATION OF .118±.002/(3.00±0.05) DIAMETER HOLES ON P.C. BOARD IS FOR OPTIONAL PEGS.
  - PART CONFORMS TO CLASS "B" REQUIREMENTS OF COSMETIC SPECIFICATION PS-45499-002 EXCEPT IN AREA OF PEG CUT-OFF.
  - 5 CIRCUIT PARTS HAVE PEG DESIGN B. ALL OTHER CIRCUIT SIZES HAVE PEG DESIGN A.

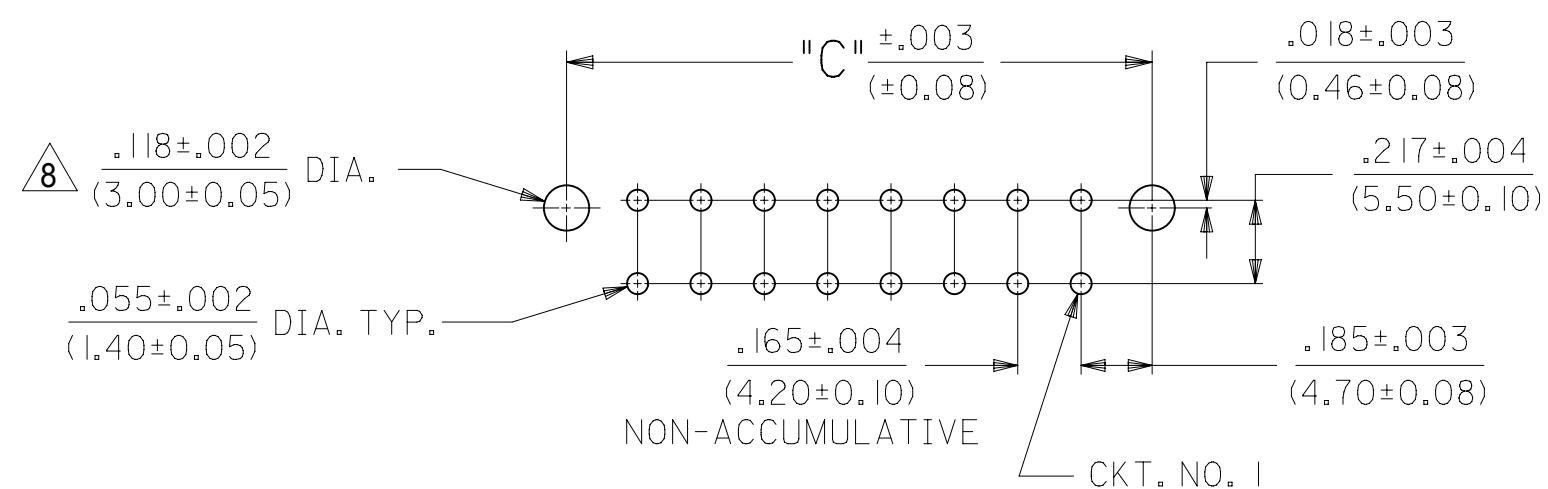
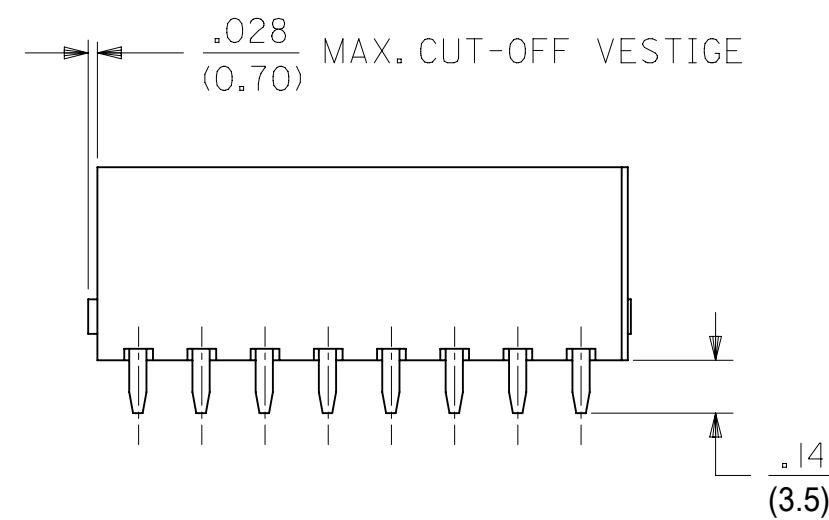
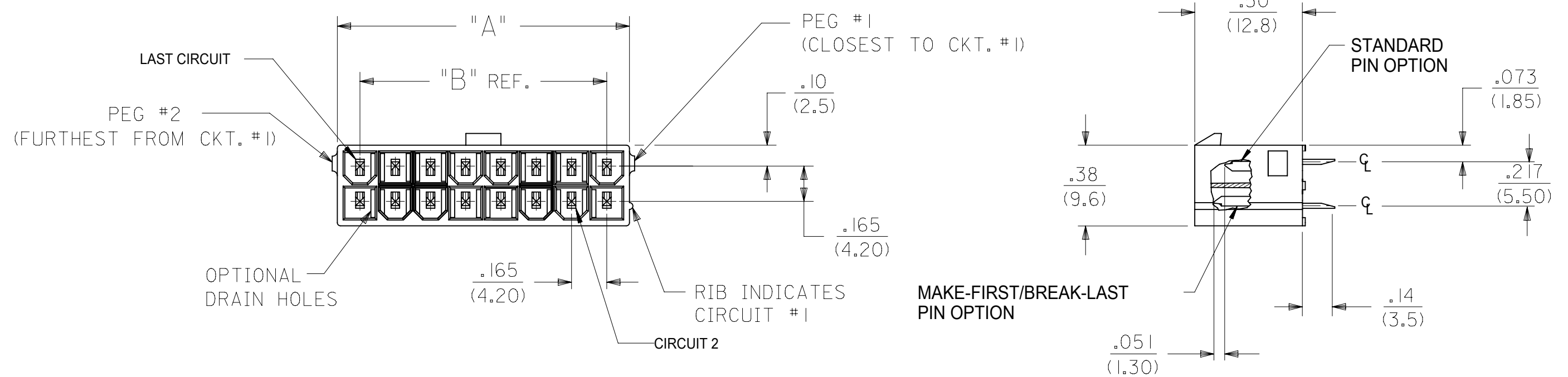

RECOMMENDED HOLE LAYOUT FOR .070/(1.78) MAX. THICK P.C. BOARD  
VIEWED FROM COMPONENT SIDE  
(SEE NOTE 8)

SEE SHEET 2 FOR SINGLE ROW PRODUCT

THIS DRAWING REPLACES DRAWING SDA-43588\*\*\*\*

THIS DRAWING CONTAINS INFORMATION THAT IS PROPRIETARY TO MOLEX ELECTRONIC TECHNOLOGIES, LLC AND SHOULD NOT BE USED WITHOUT WRITTEN PERMISSION									
SYMBOLS		DIMENSION UNITS		SCALE		CURRENT REV DESC: MIGRATE TO ECTR			
∇ = 0	∇ = 0	IN/MM	2:1			<b>molex</b> 2-24 CKT VERT HDR ASSY W/PEGS REMOVED OPTION MINI-FIT JR PRODUCT CUSTOMER DRAWING			
∇ = 0	∇ = 0	GENERAL TOLERANCES (UNLESS SPECIFIED)							
∇ = 0	∇ = 0	MM	INCH			EC NO: 172489 DRWN: AZAHIROVIC 2018/02/19 CHK'D: JBELL 2018/02/20 APPR: FSMITH 2018/02/22			
∇ = 0	∇ = 0	4 PLACES ±	±			INITIAL REVISION:			
∇ = 0	∇ = 0	3 PLACES ±	±			DRWN: AFG		1995/07/19	
∇ = 0	∇ = 0	2 PLACES ±	±			APPR: FSMITH		2010/03/08	
∇ = 0	∇ = 0	1 PLACE ±	±			ANGULAR TOL ± °			
∇ = 0	∇ = 0	0 PLACES ±	±			THIRD ANGLE PROJECTION		DRAWING SERIES	
∇ = 0	∇ = 0	DRAFT WHERE APPLICABLE MUST REMAIN WITHIN DIMENSIONS				C-SIZE		43588	
						DOCUMENT NUMBER		DOC TYPE   DOC PART   REVISION	
						435880000-SD		PSD 000 A	
						MATERIAL NUMBER		CUSTOMER	
						SEE SHEET 3			
						SHEET NUMBER		1 OF 4	

CKT SIZE	DIM A	DIM B
2	.378 (9.60)	.165 (4.20)
4	.709 (18.00)	.496 (12.60)
5	.874 (22.20)	.661 (16.80)
6	1.039 (26.40)	.827 (21.00)
7	1.205 (30.60)	.992 (25.20)
8	1.370 (34.80)	1.157 (29.40)
9	1.535 (39.00)	1.323 (33.60)
10	1.701 (43.20)	1.488 (37.80)
11	1.866 (47.40)	1.654 (42.00)
12	2.031 (51.60)	1.819 (46.20)

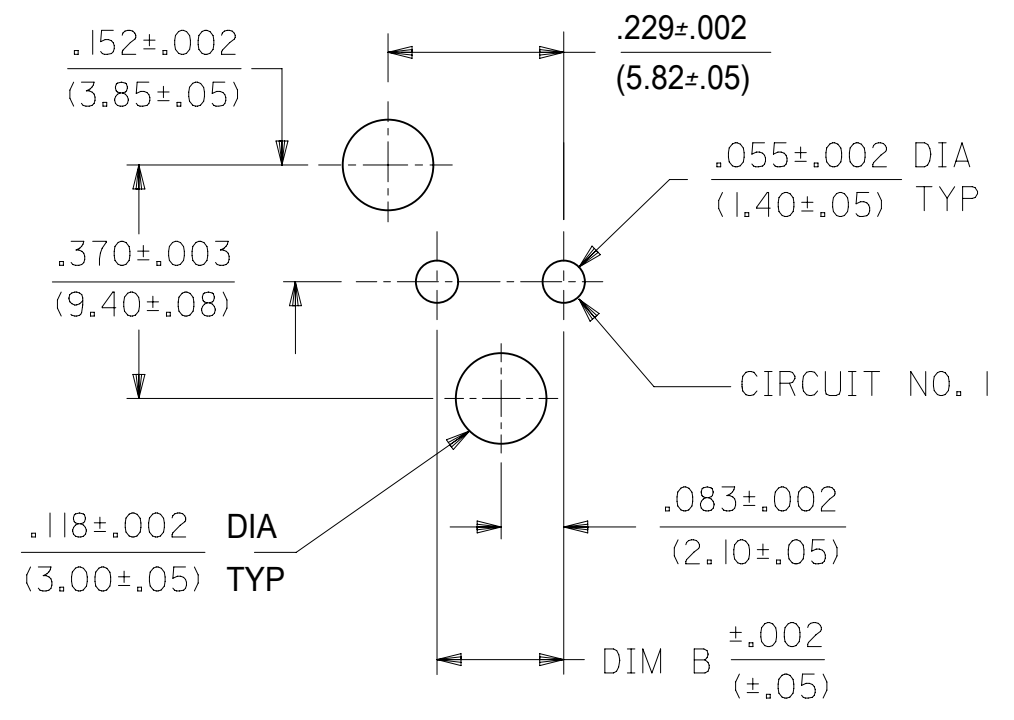
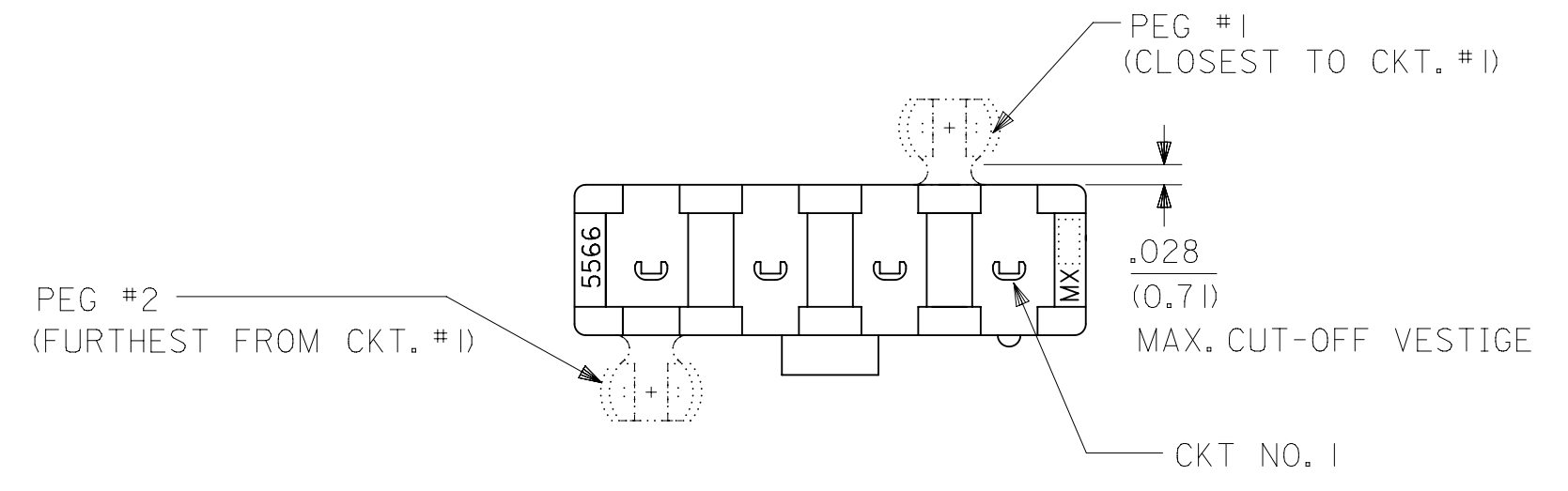
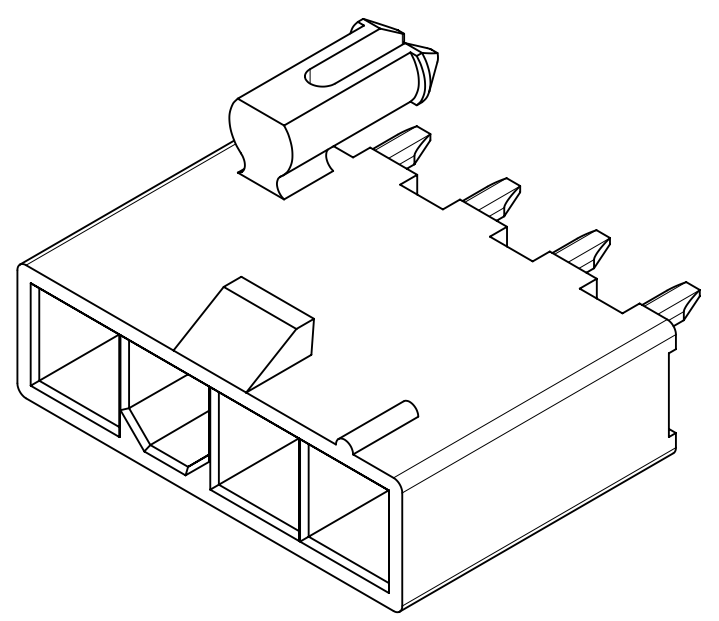

RECOMMENDED HOLE LAYOUT FOR  
.070/(1.78) MAX. THICK P. C. BOARD  
VIEWED FROM COMPONENT SIDE  
FOR 2 CIRCUIT SINGLE ROW HEADER  
(SEE NOTE 8)

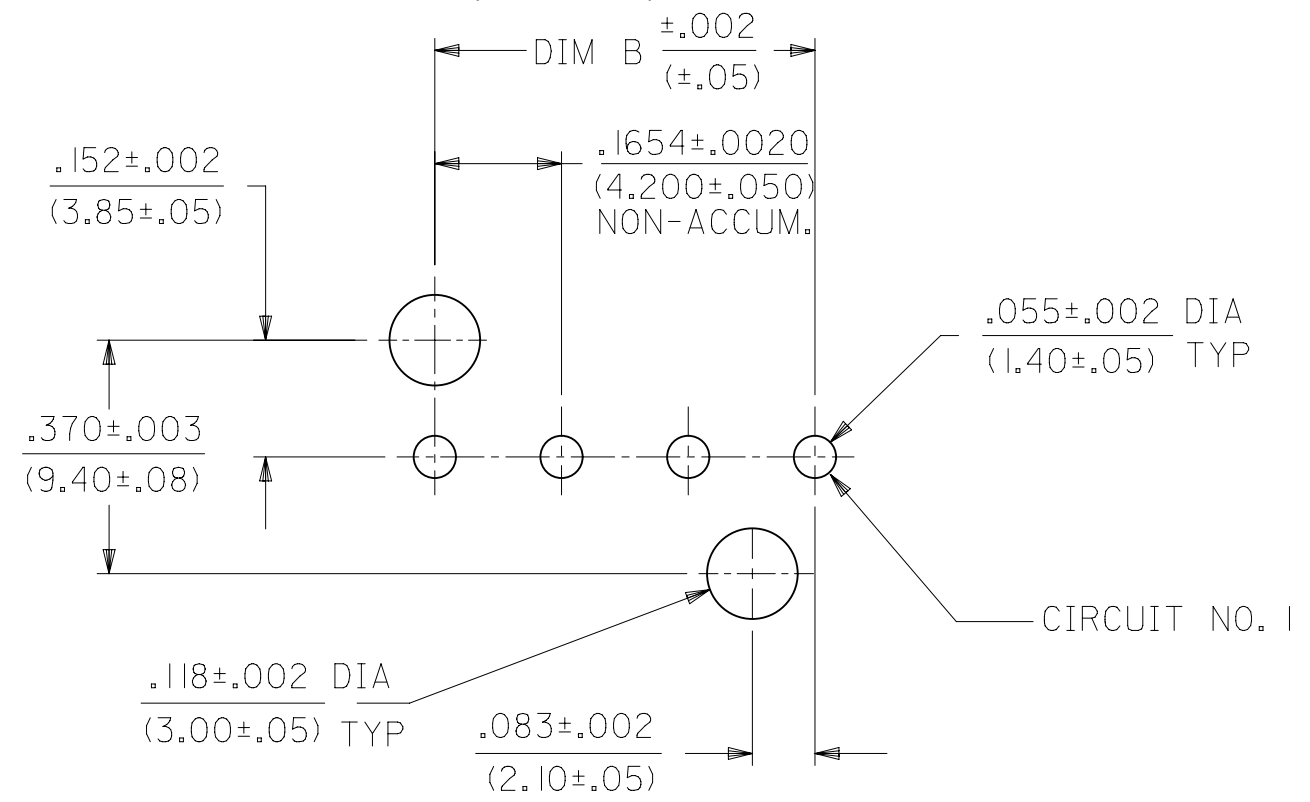
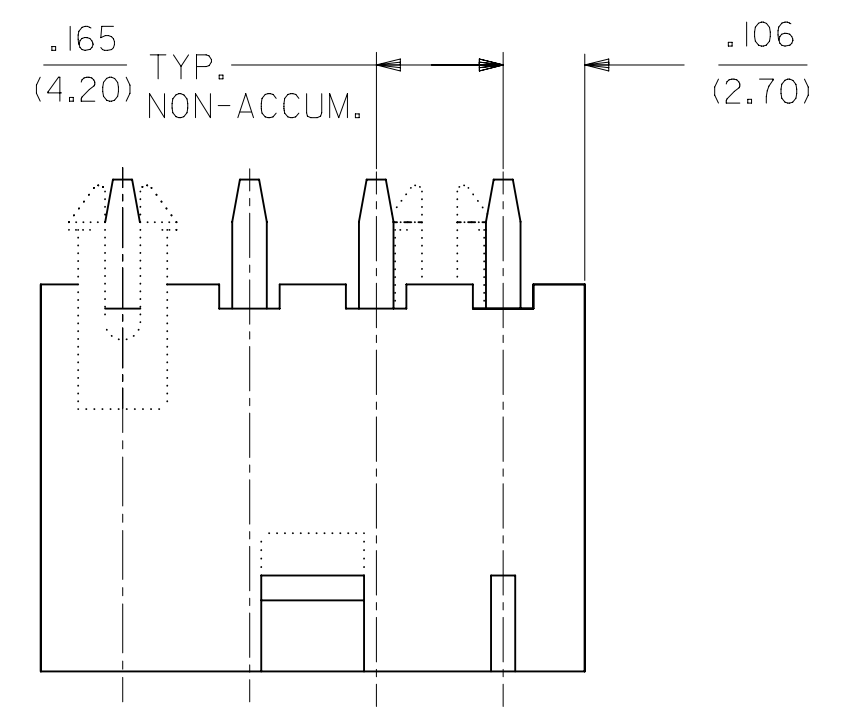
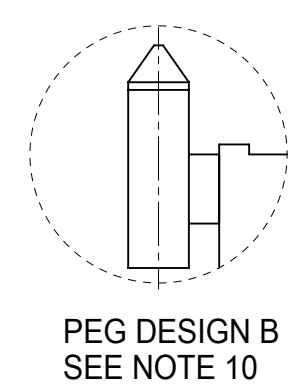
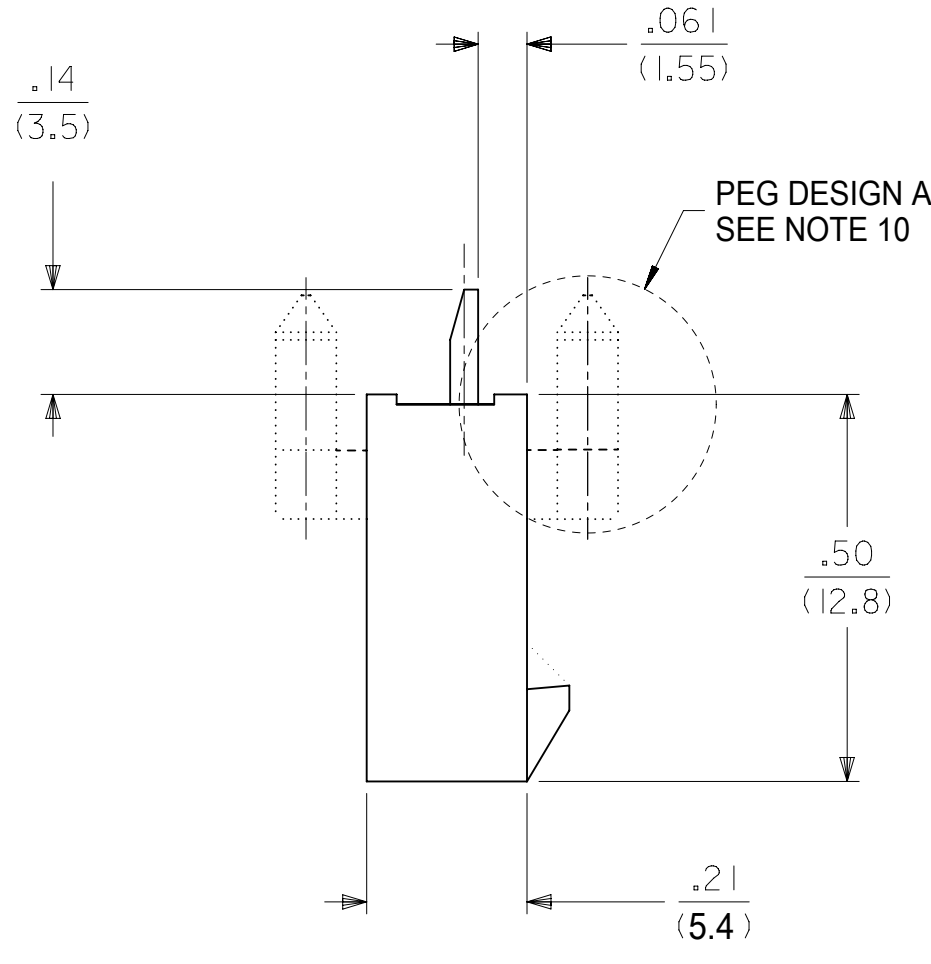

RECOMMENDED HOLE LAYOUT FOR  
.070/(1.78) MAX. THICK P. C. BOARD  
VIEWED FROM COMPONENT SIDE  
FOR 4 TO 6 CIRCUIT SINGLE ROW HEADER  
(SEE NOTE 8)

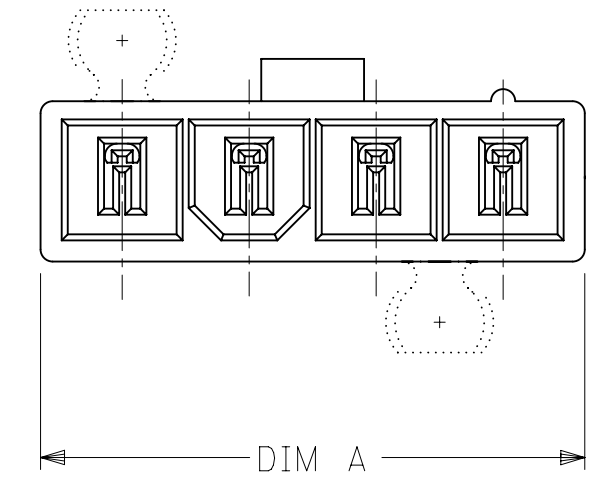

SEE SHEET 1 FOR DUAL ROW PRODUCT

THIS DRAWING CONTAINS INFORMATION THAT IS PROPRIETARY TO MOLEX ELECTRONIC TECHNOLOGIES, LLC AND SHOULD NOT BE USED WITHOUT WRITTEN PERMISSION									
SYMBOLS		DIMENSION UNITS		SCALE		CURRENT REV DESC: MIGRATE TO ECTR			
▽ = 0	IN/MM	2:1		EC NO: 172489 DRWN: AZAHIROVIC 2018/02/19 CHK'D: JBELL 2018/02/20 APPR: FSMITH 2018/02/22 INITIAL REVISION: DRWN: AFG 1995/07/19 APPR: FSMITH 2010/03/08					
▽ = 0	GENERAL TOLERANCES (UNLESS SPECIFIED)								
▽ = 0	MM	INCH							
▽ = 0	4 PLACES	±	±						
▽ = 0	3 PLACES	±	±	<b>molex</b> 2-24 CKT VERT HDR ASSY W/PEGS REMOVED OPTION MINI-FIT JR PRODUCT CUSTOMER DRAWING DOCUMENT NUMBER: 435880000-SD DOC TYPE: PSD DOC PART: 000 REVISION: A MATERIAL NUMBER: SEE SHEET 3 CUSTOMER: SEE SHEET 3 SHEET NUMBER: 2 OF 4					
▽ = 0	2 PLACES	±	±						
▽ = 0	1 PLACE	±	±						
▽ = 0	0 PLACES	±	±						
□ = 0	ANGULAR TOL	±	°	THIRD ANGLE PROJECTION		DRAWING		SERIES	
■ = 0	DRAFT WHERE APPLICABLE MUST REMAIN WITHIN DIMENSIONS			C-SIZE		43588			

DOCUMENT STATUS	P1	RELEASE DATE	2018/02/22	21:31:11
-----------------	----	--------------	------------	----------

ITEM NO.	CKTS	MATERIAL	HOUSING TYPE	DRAIN HOLES	PEG 1	PEG 2	PLATING PER NOTE 2	TERMINAL VERSION REQUIRED AT EACH CIRCUIT LOCATION: V = VOID																								PACKAGING
								1	2	3	4	5	6	7	8	9	10	11	12	13	14	15	16	17	18	19	20	21	22	23	24	
43588-2001	20	94V-2	DUAL ROW	YES	WITH	REMOVED	A	1	1	1	1	1	1	1	1	1	1	1	1	1	1	1	1	1	1	1	-	-	-	-	PK-44206-001	
43588-2007	20	94V-2	DUAL ROW	NO	REMOVED	WITH	A	1	1	1	1	1	1	1	1	1	1	1	1	1	1	1	1	1	1	1	-	-	-	-	PK-5566-003	
43588-0012	05	94V-0	SINGLE ROW	NO	WITH	WITH	C	4	V	V	V	4	-	-	-	-	-	-	-	-	-	-	-	-	-	-	-	-	-	PK-5566-002		
43588-0017	04	94V-0	SINGLE ROW	NO	REMOVED	WITH	C	4	V	V	4	-	-	-	-	-	-	-	-	-	-	-	-	-	-	-	-	-	-	PK-5566-002		
43588-0018	04	94V-0	SINGLE ROW	NO	WITH	WITH	C	4	5	5	4	-	-	-	-	-	-	-	-	-	-	-	-	-	-	-	-	-				
43588-0020	06	94V-2	DUAL ROW	NO	NONE	NONE	C	4	V	4	4	V	4	-	-	-	-	-	-	-	-	-	-	-	-	-	-	-	-	PK-5566-003		
43588-0021	14	94V-0	DUAL ROW	NO	NONE	NONE	B	3	3	3	3	3	3	3	3	3	3	3	3	3	V	3	3	-	-	-	-	-	-			
43588-0022	24	94V-0	DUAL ROW	NO	WITH	REMOVED	D	6	6	6	6	6	6	6	6	6	6	6	6	6	6	6	6	6	6	6	6	6	6	PK-5566-001		
43588-0023	05	94V-0	SINGLE ROW	NO	REMOVED	REMOVED	D	6	6	6	6	6	-	-	-	-	-	-	-	-	-	-	-	-	-	-	-	-	-	PK-43588-001		
43588-0024	06	94V-0	DUAL ROW	NO	NONE	NONE	C	4	V	4	4	V	4	-	-	-	-	-	-	-	-	-	-	-	-	-	-	-	-	PK-5566-001		



TERMINAL CODES		
TERMINAL TYPE	PLATING SEE NOTE 2	MATERIAL
1 = STANDARD	A	BRASS
3 = STANDARD	B	BRASS
4 = STANDARD	C	BRASS
5 = MF/BL	C	BRASS
6 = STANDARD	D	BRASS
7 = MF/BL	D	BRASS

SYMBOLS	THIS DRAWING CONTAINS INFORMATION THAT IS PROPRIETARY TO MOLEX ELECTRONIC TECHNOLOGIES, LLC AND SHOULD NOT BE USED WITHOUT WRITTEN PERMISSION									
	DIMENSION UNITS		SCALE		CURRENT REV DESC: MIGRATE TO ECTR					
▽ = 0	IN/MM		1:1		EC NO: 172489 DRWN: AZAHIROVIC 2018/02/19 CHK'D: JBELL 2018/02/20 APPR: FSMITH 2018/02/22 INITIAL REVISION: DRWN: AFG 1995/07/19 APPR: FSMITH 2010/03/08					
▽ = 0	GENERAL TOLERANCES (UNLESS SPECIFIED)									
▽ = 0										
▽ = 0										
▽ = 0	4 PLACES ±		±		PRODUCT CUSTOMER DRAWING DOCUMENT NUMBER: 435880000-SD DOC TYPE: PSD DOC PART: 000 REVISION: A					
▽ = 0	3 PLACES ±		±							
▽ = 0	2 PLACES ±		±		MATERIAL NUMBER: SEE SHEET 3 CUSTOMER: SHEET NUMBER: 3 OF 4					
▽ = 0	1 PLACE ±		±							
▽ = 0	0 PLACES ±		±							
▽ = 0	ANGULAR TOL ± °				THIRD ANGLE PROJECTION		DRAWING		SERIES	
▽ = 0	DRAFT WHERE APPLICABLE MUST REMAIN WITHIN DIMENSIONS						C-SIZE		43588	

