

NOTES:

1. MATERIALS AND FINISHES:
 BODY - BRASS, ALBALOY PLATING
 CONTACT - PHOSPHOR BRONZE, GOLD PLATING
 INSULATOR - PTFE, NATURAL
2. ELECTRICAL:
 A. IMPEDANCE: 50 OHM
 B. FREQUENCY RANGE: 0-6 GHz
 C. VSWR (RETURN LOSS): 1.3 MAX.
 D. DIELECTRIC WITHSTANDING VOLTAGE: 2500 VRMS, MIN.
3. MECHANICAL:
 A. DURABILITY: 500 CYCLES MIN.
 B. TEMPERATURE RANGE: -65° C TO +165° C
4. CONTACT PIN TO SOLDER
5. RECOMMENDED THAT THE TORQUE TO APPLY THE REAR BODY SHOULD NOT EXCEED 8 IN-LBS.

THIRD ANGLE PROJ.

REVISIONS

REV	DESCRIPTION	DATE	ECN	APPR
NC	INITIAL RELEASE	30-Jul-09	-----	MZ
B	THE INSULATOR WAS CHANGED \RD-DM11081901M	08-Sep-11	-----	SH
C	SYNC, ADDED THE NOTES 5	03-Jun-19	11702	CJV

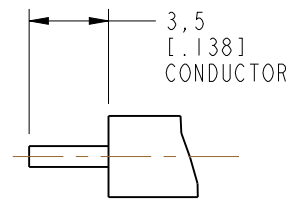

**RECOMMENDED
CABLE STRIPPING DIM'S**

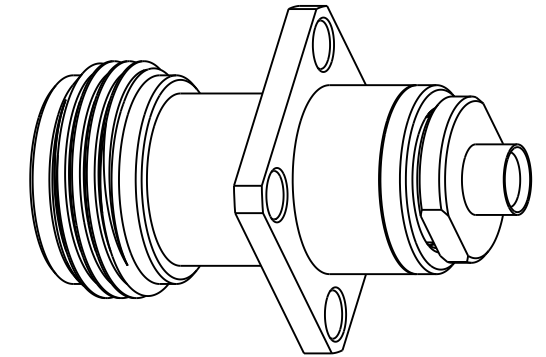

SCALE 2.000

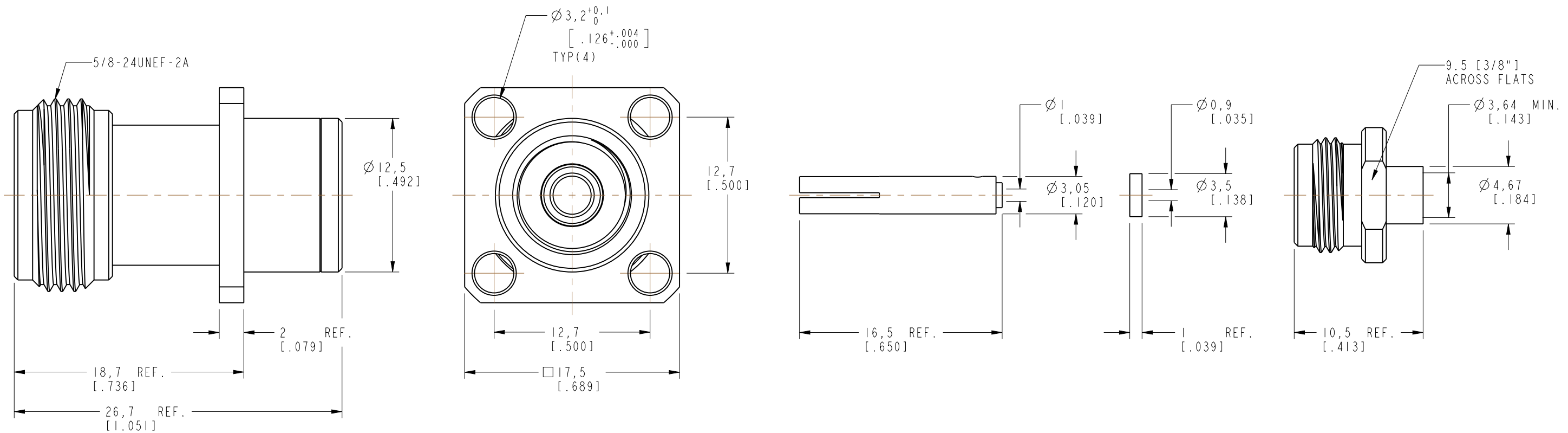

CUSTOMER OUTLINE DRAWING
ALL OTHER SHEETS ARE FOR INTERNAL USE ONLY

UNLESS OTHERWISE SPECIFIED, DIMENSIONS ARE IN METRIC AND TOLERANCES ARE: <0.5mm ± 0.05mm 0.5 - 6mm ± 0.1mm 6 - 30mm ± 0.2mm 30 - 120mm ± 0.3mm ANGLES ± 1°	MATERIAL SEE NOTES	DRAWN M. ZHANG	DATE 11-Apr-19	TITLE N PANEL DIRECT SOLDER JACK (FOR .141" CABLE)		Amphenol RF www.amphenolrf.com	
	REFERENCE	ENGINEER C. WANG	DATE 23-Nov-09				
NOTICE - These drawings, specifications, or other data (1) are, and remain the property of Amphenol corp. (2) must be returned upon request; and (3) are confidential and not to be disclosed to any person other than those to whom they are given by Amphenol Corp. the furnishing of these drawings, specifications, or other data by Amphenol Corp., or to any other person to anyone for any purpose is not to be regarded by implication or otherwise in any manner licensing, granting rights to permitting such holder or any other person to manufacture, use or sell any product, process or design, patented or otherwise, that may in any way be related to or disclosed by said drawings, specifications, or other data.	EAR#	APPROVED K. CAPOZZI	DATE 03-Jun-19	SCALE: 3.0:1.0	SHEET 2 OF 2	DRAWING NO. N6581A7-002-AX3GT30GA-50	
	CONFIGURATION LEVEL: In Work	CAD FILE	DWG SIZE B	REV C	ITEM NO. 036581AAY42AW5F		
	FINISH				PART NO. 172170-10		