

■ Input-output condition

Item	Specification
Input voltage range	DC110~450V
Rated input voltage	DC140V, DC340V
Rated output voltage	24V
Rated load current	0.5A

■ Electrical specification Ta=25°C

Item	Specification	Conditions · Note
Efficiency	More than 80%	Rated input voltage Rated output current
Output voltage tolerance	±5%	
Line regulation	Less than 100mV	Input voltage DC110V~450V
Load regulation	Less than 250mV	Output current 0~0.5A
No-load power	Less than 80mW	Rated input voltage
Ripple	Less than 240mVp-p	Rated input voltage
Ripple noise	Less than 300mVp-p	Rated output current

Measurement circuit

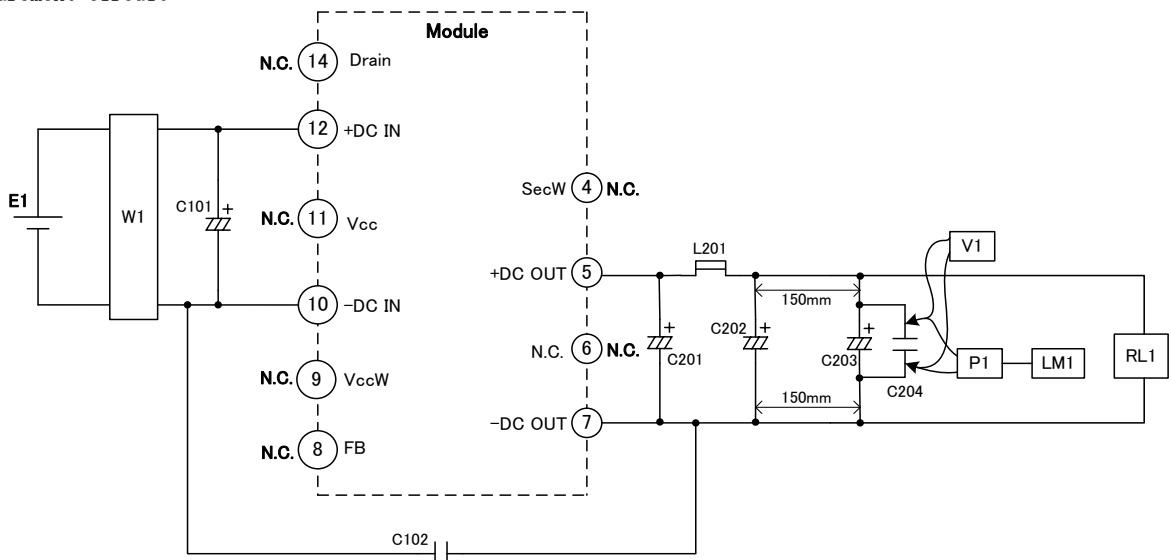

- E1 : DC power supply
- W1 : Wattmeter WT210 (YOKOGAWA)
- RL1 : Electronic load
- V1 : Voltmeter Class 0.5
- P1 : Differential probe DP-100 (KG)
- LM1 : Ripple noise meter RM-103 (KG)

- C101 : 450BXC33M (RUBYCON)
- C102 : CD85-E2GA102M (TDK)
- C201 : 35ZLG220M (RUBYCON)
- C202 : 35ZLG220M (RUBYCON)
- C203 : 25ZLG47M (RUBYCON)
- C204 : 50F2D104K (RUBYCON)
- L201 : PJ5H-2R2M (KORIN)

■Protection

Item	Specification	Conditions · Note
Overcurrent protection	More than 0.53A	Auto recovery
Overvoltage protection	27.6~33.6V	Latch off
Overheat protection		Latch off

■Insulation

Item	Specification	Conditions · Note
Insulation voltage (Between Pri-Sec)	3.0kV (or 3.6kV)	AC 1min (or AC 2sec) Cutoff 2mA
Insulation resistance (Between Pri-Sec)	More than 100MΩ	DC500V

■Environmental conditions

Item	Specification	Conditions · Note
Operation temperature	-20°C~80°C	Stand for ambient temperature derating
Operating humidity	20~95%RH (No condensation)	
Storage temperature	-25°C~85°C	
Storage humidit	5~95%RH (No condensation)	

■Ambient temperature derating curve

Reduce the load current according to the following temperature derating table.

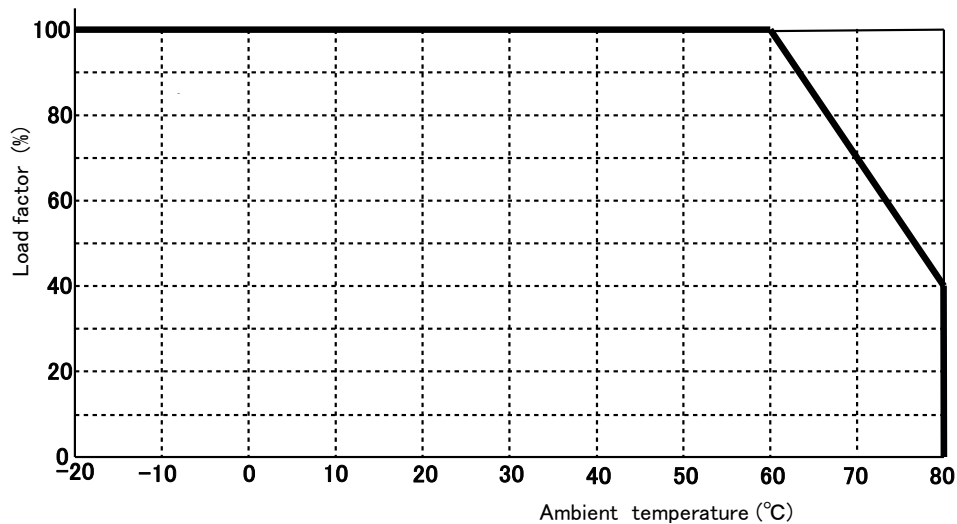

■ Typical characteristics Ta=25°C

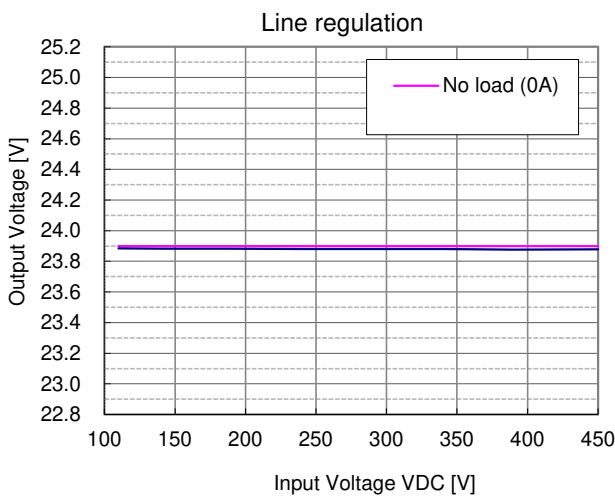
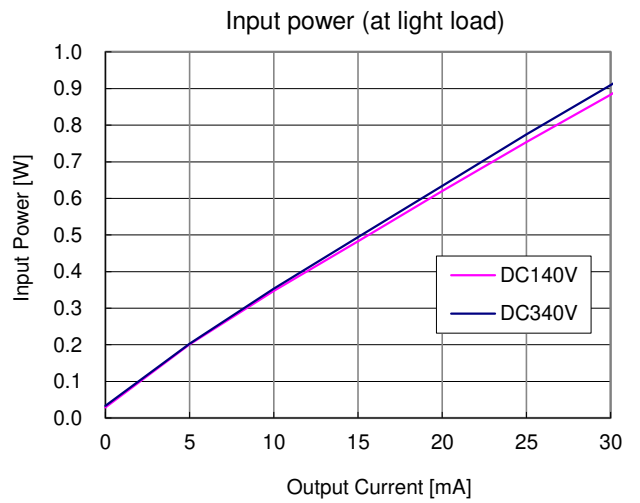
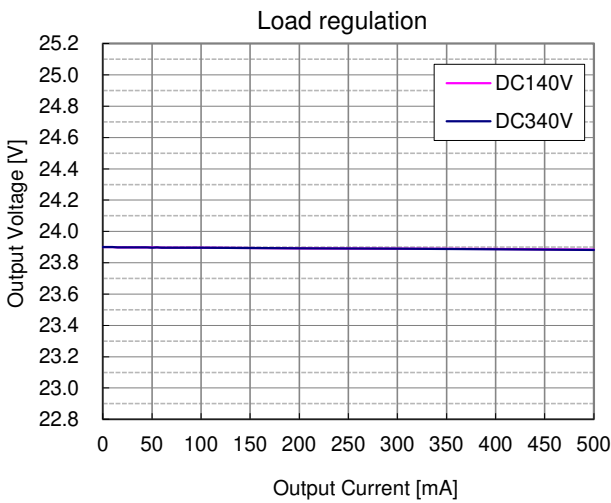
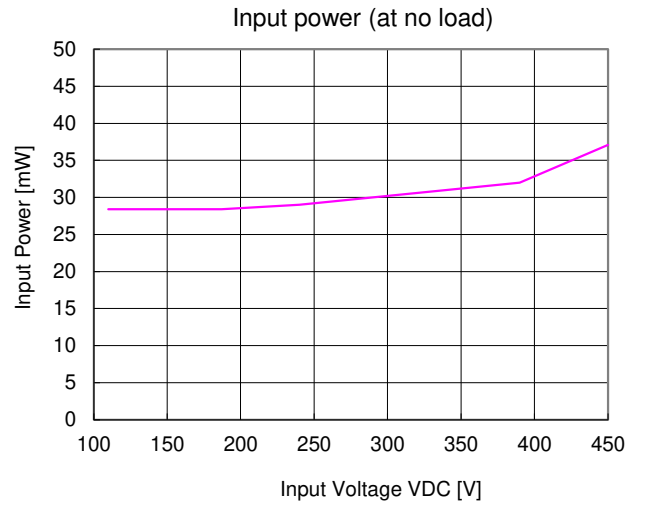
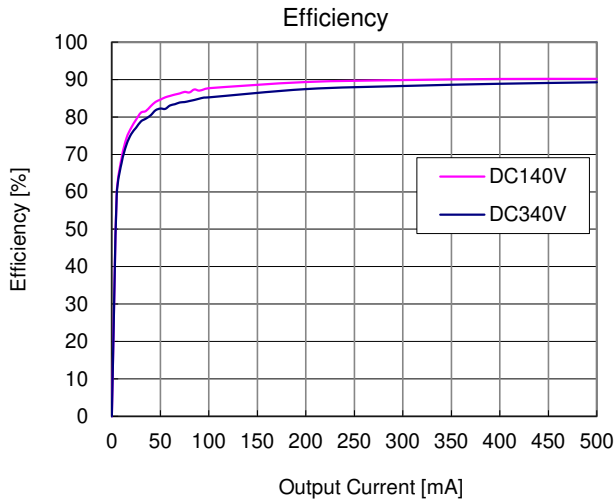

■Outline dimensional drawing

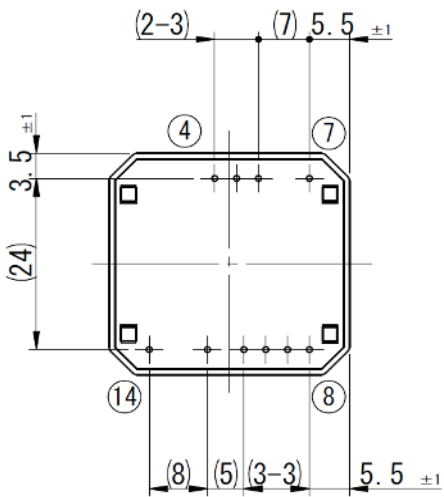
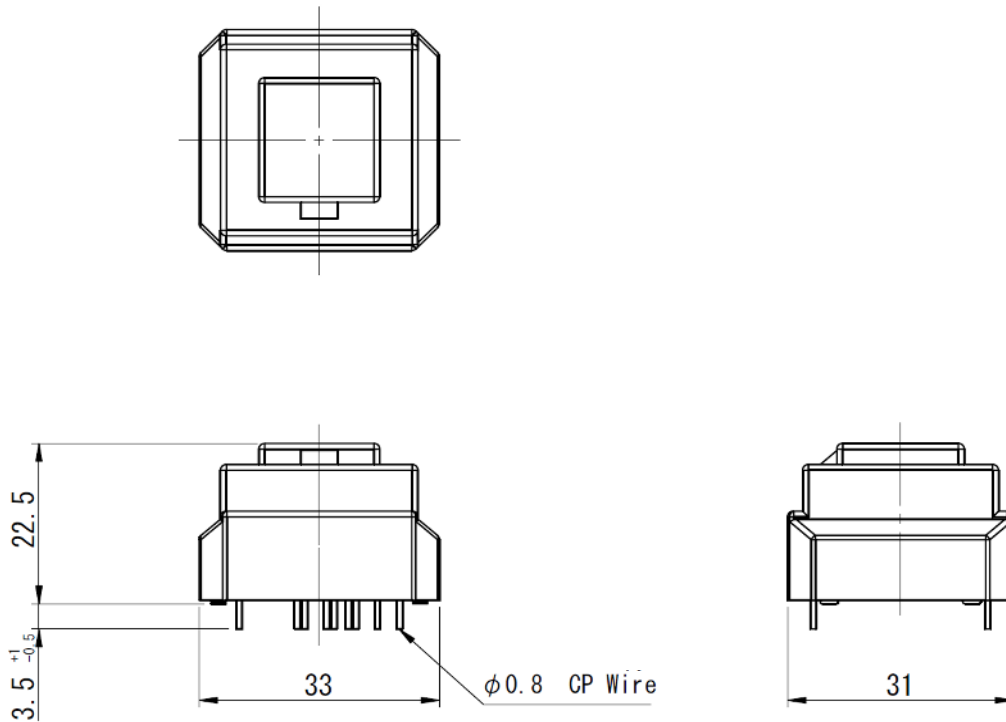

Note :1. The dimensional tolerance without directions is $\pm 0.5\text{mm}$.

Unit : mm

■Recommended hole diameter and land size

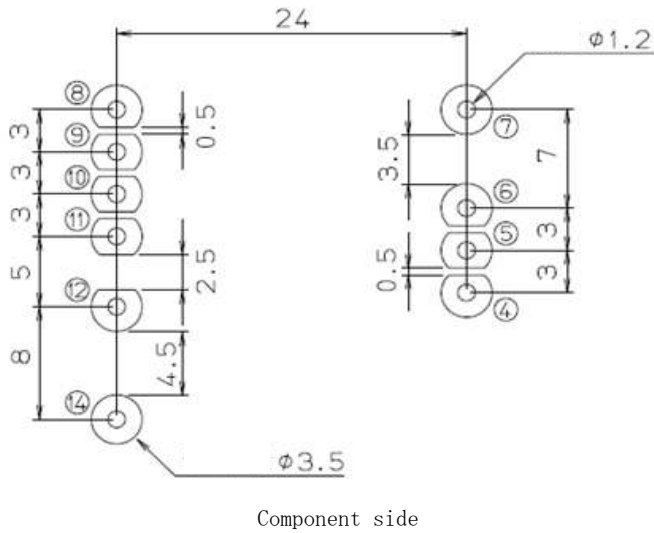

※ The round pulling out figure is a pin numbering.

Unit : mm

■Terminal function and connection

Secondaries

Pin No.	Name	Explanation of terminals
1		No terminal
2		No terminal
3		No terminal
4	SecW	Non-contact terminal ※Don't connect with other circuits.
5	+DC OUT	Output terminal (+)
6	N. C.	Non-contact terminal ※Don't connect with other circuits.
7	-DC OUT	Output terminal (-)

Primaries

Pin No.	Name	Explanation of terminals
8	FB	Non-contact terminal ※Don't connect with other circuits.
9	VccW	Non-contact terminal ※Don't connect with other circuits.
10	-DC IN	DC voltage input terminal (-)
11	Vcc	Terminal for start-up time adjustment
12	+DC IN	DC voltage input terminal (+)
13		No terminal
14	Drain	Terminal for noise adjustment

Application circuit example

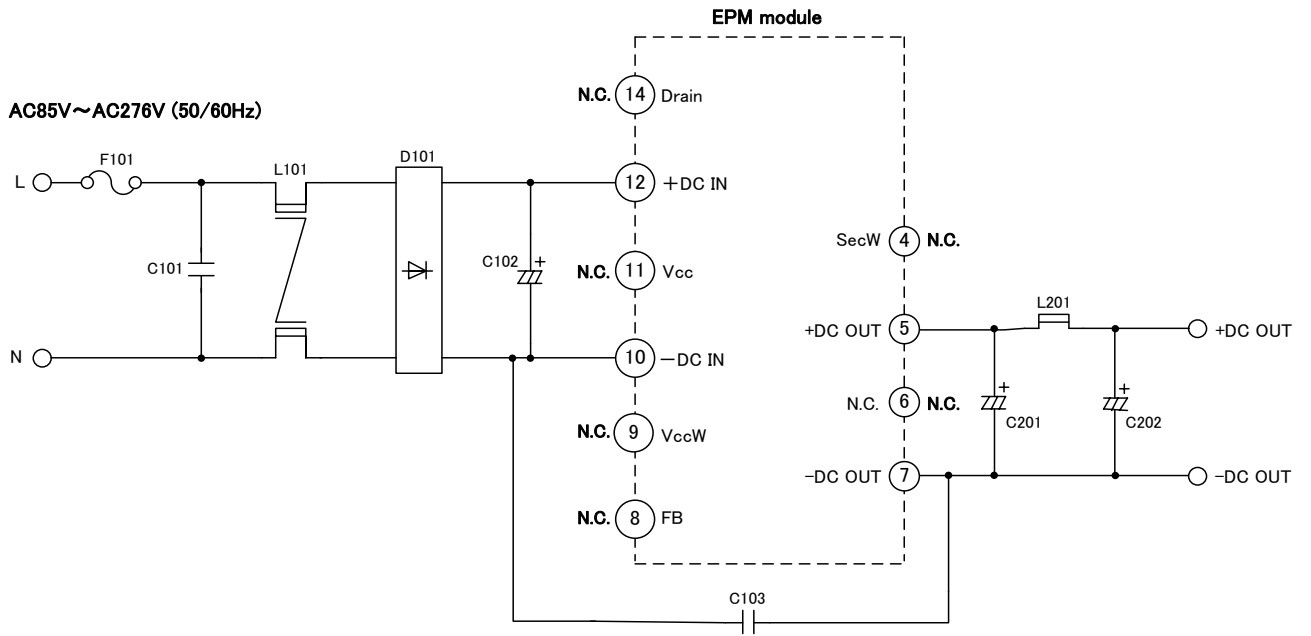

Symbol	Description	Part No.	Manufacturer
D101	Diode	D2SB60	SHINDENGEN
L101	Inductor	LF-4Z-E333	KORIN
L201	Inductor	PJ5H-2R2M	KORIN
C101	Capacitor	LE104-MX	OKAYA
C102	Capacitor	450BXC33M	RUBYCON
C103	Capacitor	CD85-E2GA102M	TDK
C201	Capacitor	35ZLG220M	RUBYCON
C202	Capacitor	35ZLG220M	RUBYCON
F101	Fuse	FCT 250V 1.6A	NIPPON-SEISEN