

REVISIONS				
REV.	ECO. NO	DESCRIPTION	DATE	BY
F	3759	ADD EMPP (SPINODAL) OPTION	10/16/2017	JH/JT
H	4221	ADD REF ROW SPACING DIM	6/1/2020	JH

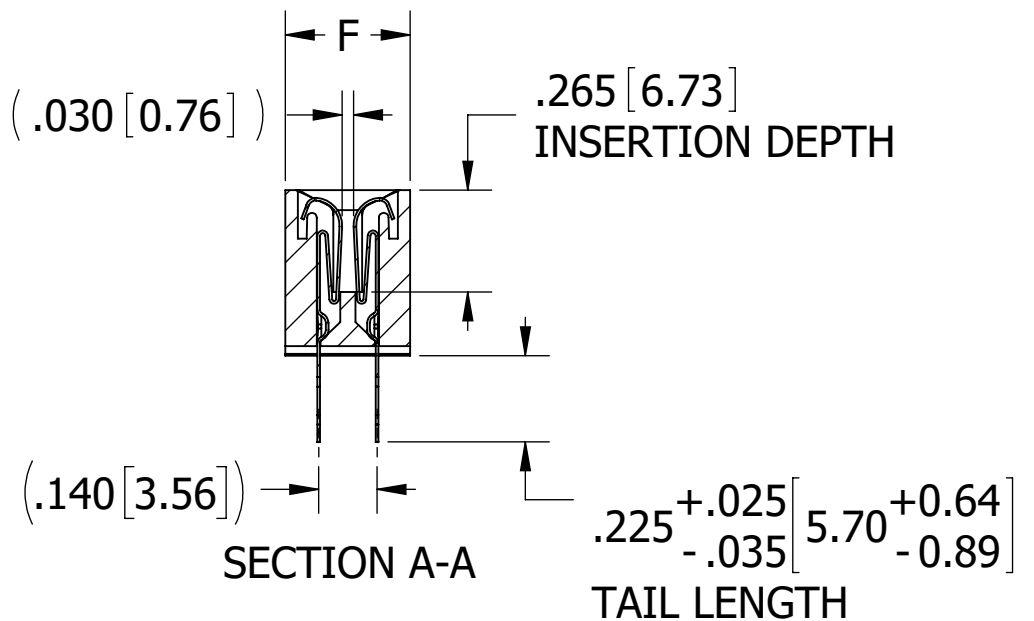
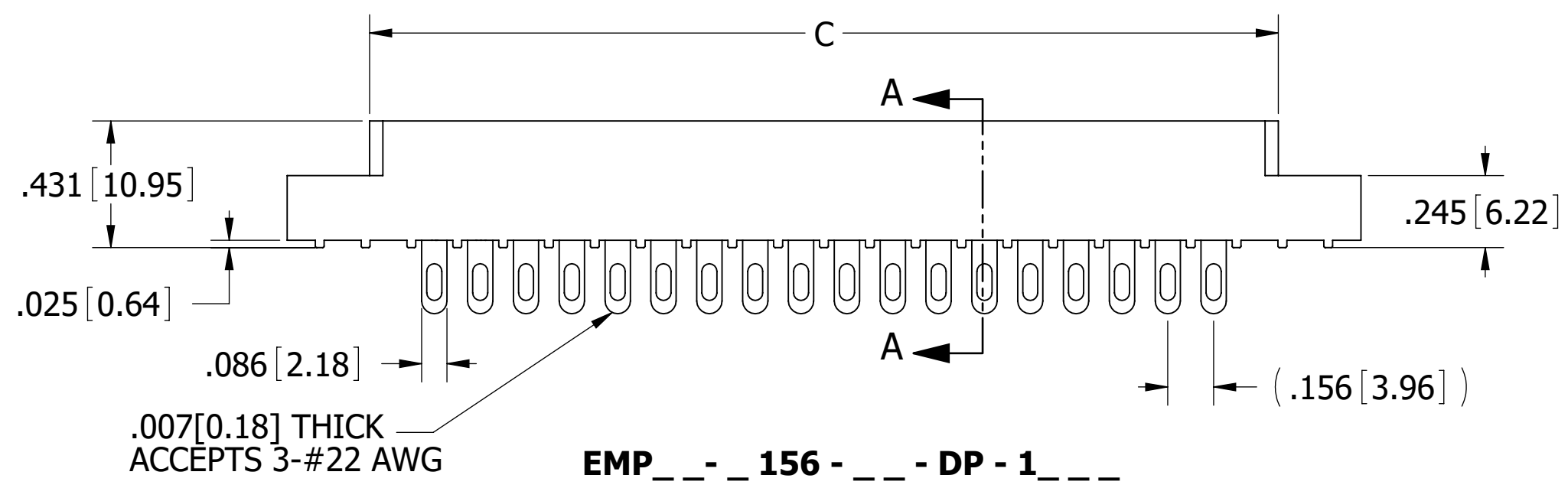
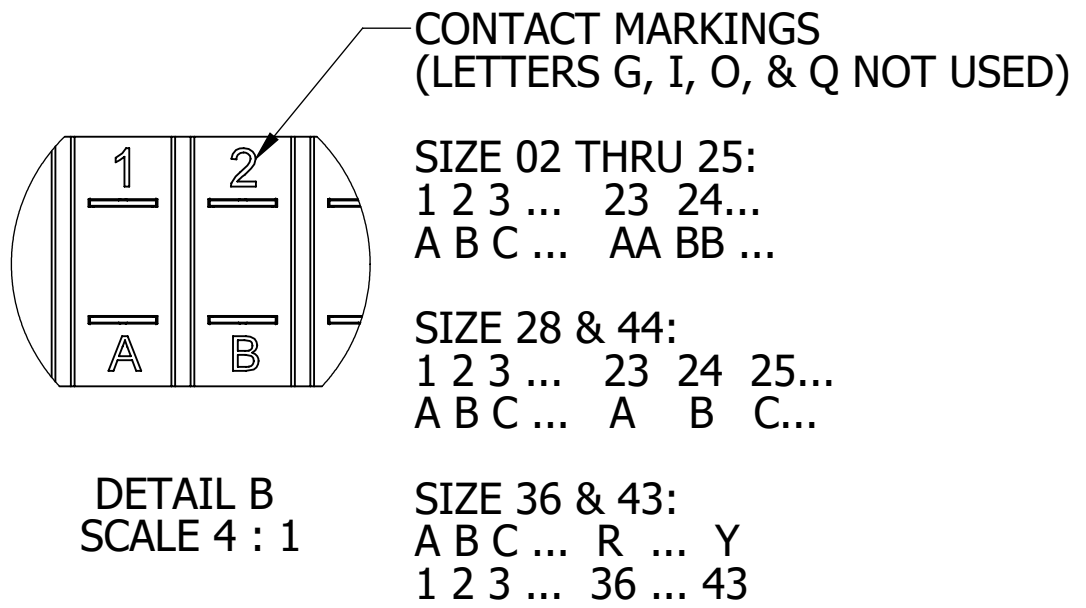
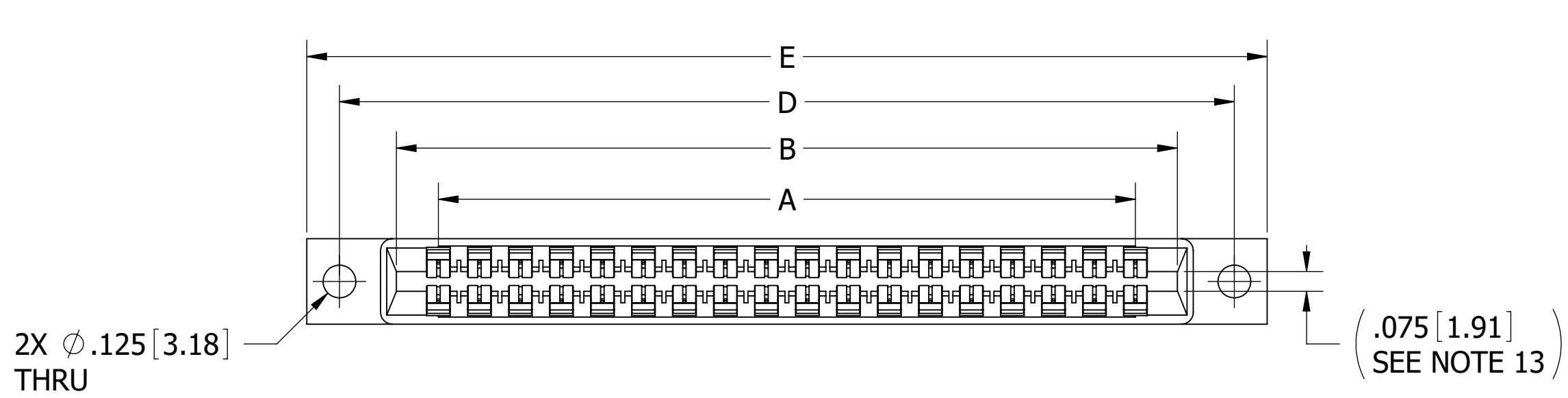

**NOTES:**

- INSULATOR MATERIAL: SEE PART NUMBER CODING
- CONTACT MATERIAL: SEE PART NUMBER CODING
- PLATING: SEE PART NUMBER CODING
- OPERATING TEMPERATURE: SEE PART NUMBER CODING
- PROCESSING TEMP: SEE PART NUMBER CODING
- UL FLAMMABILITY RATING: 94V-0
- OPERATING VOLTAGE: 950 VAC
- CURRENT RATING: 3 AMP
- CONTACT RESISTANCE: 30 MILLI OHMS MAX
- INSULATION RESISTANCE: 5000 MEGA OHMS
- DURABILITY: 500 CYCLES MIN
- CONNECTOR IDENTIFICATION: THE PART SHALL BE MARKED WITH A PART NUMBER AND LOT CODE
- BOARD THICKNESS ACCOMMODATED: .062 ± .008 [1.57 ± 0.20]
- INSERTION FORCE: 16 OZ MAX PER CONTACT PAIR WHEN USING A .062 [1.57] TEST BLADE  
INTERNAL INSPECTION TO BE PER SULLINS WORK INSTRUCTION WI-8.6-03
- WITHDRAWAL FORCE: 1 OZ MIN PER CONTACT PAIR USING .062 [1.57] TEST BLADE

REF: \_ \_ M \_ DSE \_ - \_ \_ \_

**CUSTOMER COPY**



UNLESS OTHERWISE SPECIFIED: DIMENSIONS ARE IN INCHES [MM]		DRAWN	DATE	NAME		
TOLERANCES: ANGULAR: ± 1° DECIMALS .XX = ± .02 [.5] .XXX = ± .005 [1.3] .XXXX = ± .0005 [0.13]		6/7/2011	JH	JH		
<small>THE INFORMATION HEREIN CONTAINS PROPRIETARY INFORMATION OF SULLINS ELECTRONICS AND IS NOT TO BE REPRODUCED, USED OR DISCLOSED TO OTHERS FOR ANY PURPOSE EXCEPT AS SPECIFICALLY AUTHORIZED IN WRITING BY AN OFFICER OF SULLINS ELECTRONICS.</small>					TITLE <b>EDGE CARD, .156 CC LP</b>	
PART NUMBER <b>EMP _ _ _ 156 - _ _ - DP - _ _ _</b>					SIZE <b>C</b>	CAGE CODE <b>54453</b>
SCALE: 2:1					DWG. NO. <b>C10666</b>	REV <b>H</b>
					SHEET 1 OF 3	

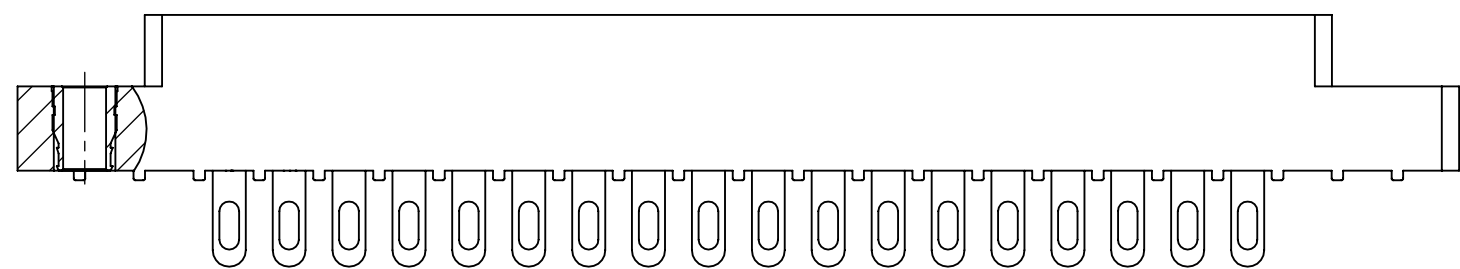
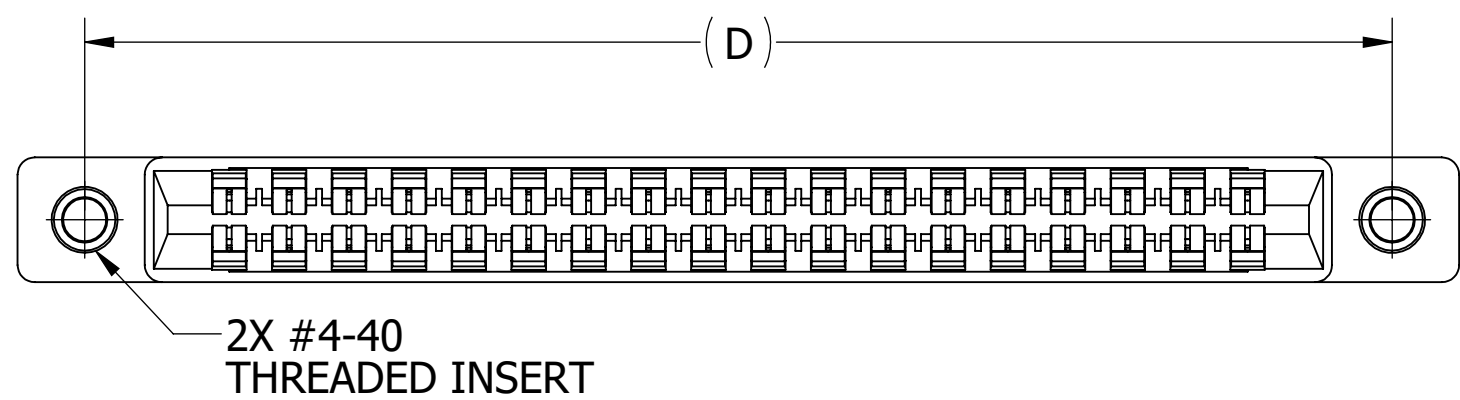

**EMP - 156 - DP - 2**

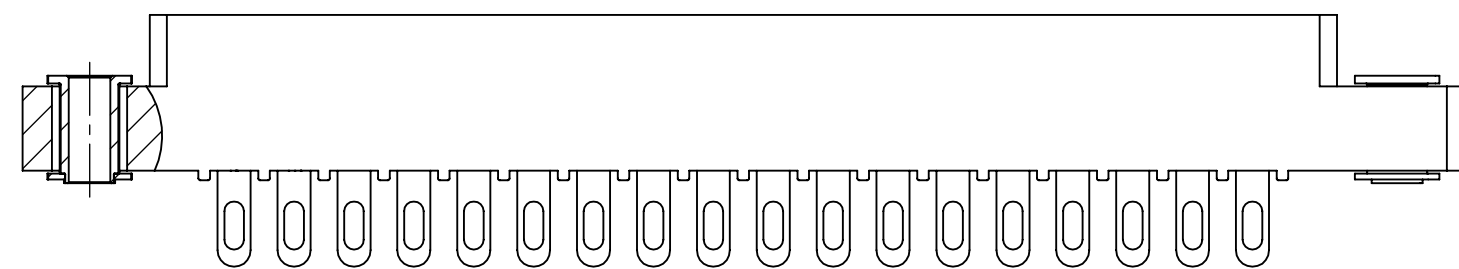
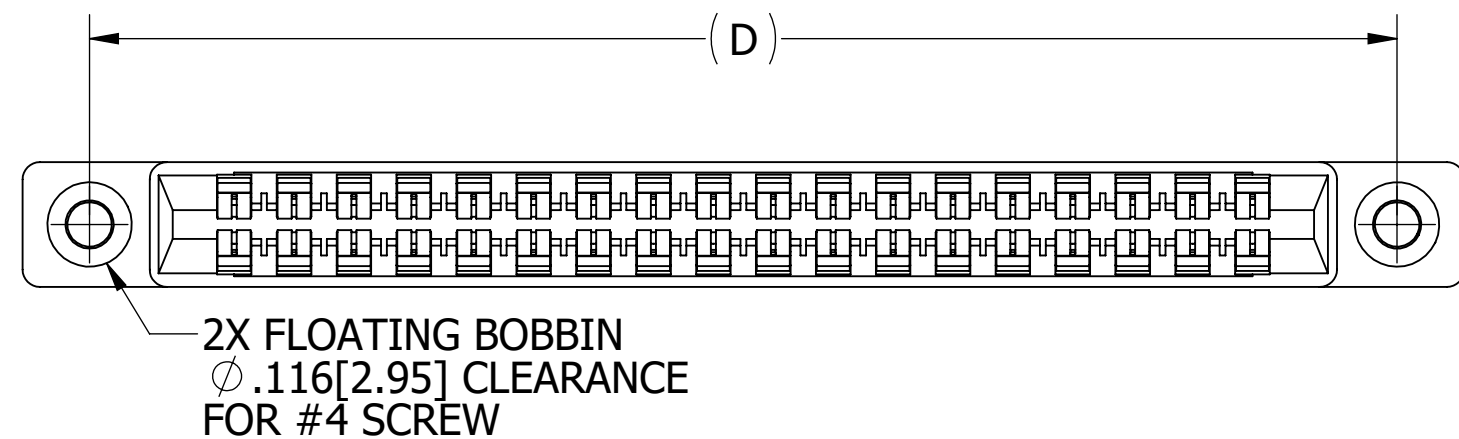

**EMP - 156 - DP - 3**

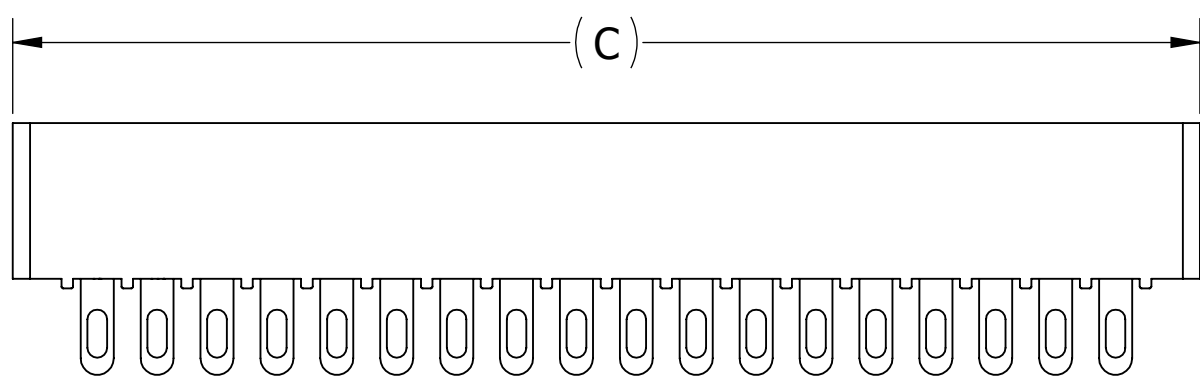
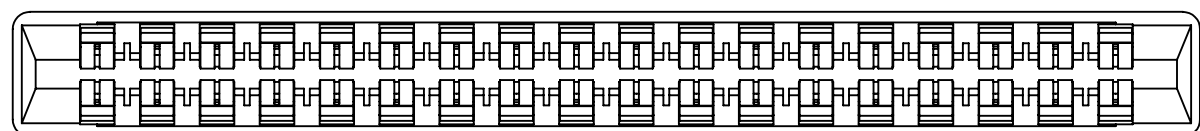

**EMP - 156 - DP - 4**

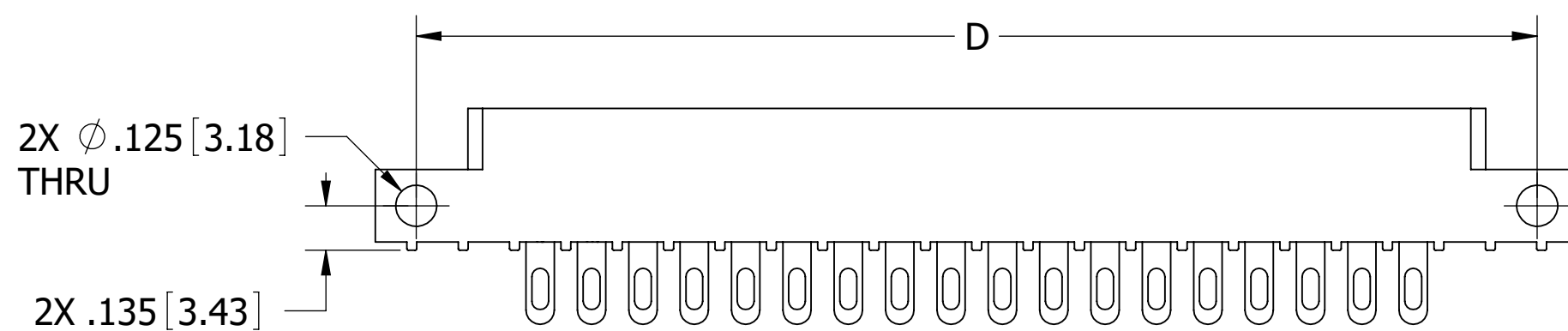
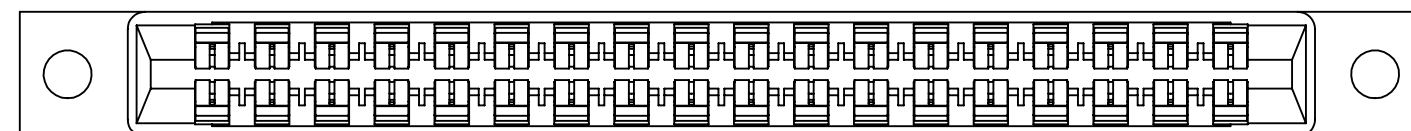

**EMP - 156 - DP - 8**

# CUSTOMER COPY



UNLESS OTHERWISE SPECIFIED:  
DIMENSIONS ARE IN INCHES [MM]

TOLERANCES:

ANGULAR: ± 1°

DECIMALS

.XX = ± .02 [.5]

.XXX = ± .005 [.13]

.XXXX = ± .0005 [.013]

DRAWN	DATE	NAME
	6/7/2011	JH

THE INFORMATION HEREIN CONTAINS  
PROPRIETARY INFORMATION OF  
SULLINS ELECTRONICS AND IS NOT  
TO BE REPRODUCED, USED OR  
DISCLOSED TO OTHERS FOR ANY  
PURPOSE EXCEPT AS SPECIFICALLY  
AUTHORIZED IN WRITING BY AN  
OFFICER OF SULLINS ELECTRONICS.

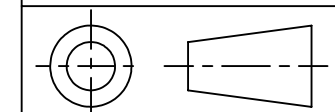

TITLE  
**EDGE CARD, .156 CC LP**

PART NUMBER  
**EMP - 156 - DP -**

SIZE	CAGE CODE	DWG. NO.	REV
<b>C</b>	<b>54453</b>	<b>C10666</b>	<b>H</b>

SCALE: 2:1 SHEET 2 OF 3

PART NUMBER	NO. OF POS.	A ± .008[0.20]		B ± .008[0.20]		C ± .015[0.38]		D ± .010[0.25]		E ± .020[0.51]		E ± .020[0.51]		F + .005 [0.13]/ - .015 [0.38]	
		IN	MM	IN	MM	IN	MM	IN	MM	IN	MM	IN	MM	IN	MM
		EMP - 156-02-DP-	2	0.156	3.96	0.476	12.09	0.596	15.14	0.909	23.09	1.158	29.41	1.258	31.95
EMP - 156-03-DP-	3	0.312	7.92	0.632	16.05	0.752	19.10	1.065	27.05	1.314	33.38	1.414	35.92		
EMP - 156-06-DP-	6	0.780	19.81	1.100	27.94	1.220	30.99	1.533	38.94	1.782	45.26	1.882	47.80		
EMP - 156-08-DP-	8	1.092	27.74	1.412	35.86	1.532	38.91	1.845	46.86	2.094	53.19	2.194	55.73		
EMP - 156-10-DP-	10	1.404	35.66	1.724	43.79	1.844	46.84	2.157	54.79	2.406	61.11	2.506	63.65		
EMP - 156-11-DP-	11	1.560	39.62	1.880	47.75	2.000	50.80	2.313	58.75	2.562	65.07	2.662	67.61		
EMP - 156-12-DP-	12	1.716	43.59	2.036	51.71	2.156	54.76	2.469	62.71	2.718	69.04	2.818	71.58		
EMP - 156-15-DP-	15	2.184	55.47	2.504	63.60	2.624	66.65	2.937	74.60	3.186	80.92	3.286	83.46		
EMP - 156-18-DP-	18	2.652	67.36	2.972	75.49	3.092	78.54	3.405	86.49	3.654	92.81	3.754	95.35		
EMP - 156-22-DP-	22	3.276	83.21	3.596	91.34	3.716	94.39	4.029	102.34	4.278	108.66	4.378	111.20		
EMP - 156-24-DP-	24	3.588	91.14	3.908	99.26	4.028	102.31	4.341	110.26	4.590	116.59	4.690	119.13		
EMP - 156-25-DP-	25	3.744	95.10	4.064	103.23	4.184	106.27	4.497	114.22	4.746	120.55	4.846	123.09		
EMP - 156-28-DP-	28	4.212	106.98	4.532	115.11	4.652	118.16	4.965	126.11	5.214	132.44	5.314	134.98		
EMP - 156-36-DP-	36	5.460	138.68	5.780	146.81	5.900	149.86	6.213	157.81	6.462	164.13	6.562	166.67		
EMP - 156-43-DP-	43	6.552	166.42	6.872	174.55	6.992	177.60	7.305	185.55	7.554	191.87	7.654	194.41		
EMP - 156-44-DP-	44	6.708	170.38	7.028	178.51	7.148	181.56	7.461	189.51	7.710	195.83	7.810	198.37		

FOR CONNECTORS WITH THREADED INSERTS OR FLOATS

**PART NUMBER CODING**

EMP - - 156 - - DP - - -

**CONTACT MATERIAL**  
 OMIT = PHOSPHOR BRONZE (SEE TABLE 2)  
 Y = BERYLLIUM COPPER (SEE TABLE 3)  
 OMIT WITH 'EMPP' PLATING CODE = SPINODAL (SEE TABLE 4)  
**PLATING MODIFICATION CODE** (SEE TABLE 1)

**MOUNTING STYLE**  
 1 = .125" DIA. CLEARANCE HOLES  
 2 = #4-40 THREADED INSERT  
 3 = FLOATING BOBBIN  
 4 = NO MOUNTING EARS  
 8 = .125" DIA. SIDE HOLES

**NUMBER OF POSITIONS**  
 (CONTACTS PER ROW)

**INSULATOR MATERIAL**  
 0 = PBT, BLUE  
 2 = PBT, GREEN  
 3 = PBT, BLACK  
 1 = PPS, BROWN  
 5 = PPS, BLACK  
 6 = PPS, GREEN  
 7 = PPS, BROWN

**PLATING** (SEE TABLE 1)

**TABLE 1 (PLATING):**

ALL PLATINGS HAVE .000050" MIN NICKEL UNDERPLATE

	CONTACT SURFACE	TERMINATION	PLATING MODIFICATION CODE
EMP, EMPP	.000010" GOLD OVERALL	.000010" GOLD OVERALL	OMIT
	.000030" GOLD	.000010" GOLD OVERALL	G
EMPSL	.000010" GOLD	.000100" PURE TIN, MATTE	K
	.000030" GOLD	.000100" PURE TIN, MATTE	GK
EMPL	.000100" PURE TIN, MATTE OVERALL	.000100" PURE TIN, MATTE OVERALL	K

1. EML AVAILABLE WITH PHOSPHOR BRONZE CONTACTS ONLY
2. EMP, EMPSL AVAILABLE IN PHOSPHOR BRONZE OR BERYLLIUM COPPER
3. EMPP = SPINODAL

**TABLE 2 (PHOSPHOR BRONZE CONTACTS): EMP, EML, EMPSL**

INSULATOR MATERIAL CODE	OPERATING TEMPERATURE	PROCESSING TEMPERATURE
0, 2, 3	-65°C TO +125°C	WAVE/MANUAL SOLDERING ONLY
1, 5, 6, 7	-65°C TO +125°C	260°C MAX FOR 20 SEC

**TABLE 3 (BERYLLIUM COPPER CONTACTS): EMP OR EMPSL WITH 'Y' MODIFICATION CODE**

INSULATOR MATERIAL CODE	OPERATING TEMPERATURE	PROCESSING TEMPERATURE
0, 2, 3	-65°C TO +125°C	WAVE /MANUAL SOLDERING ONLY
1, 5, 6, 7	-65°C TO +150°C	260°C MAX FOR 20 SEC

**TABLE 4 (SPINODAL CONTACTS): EMPP**

INSULATOR MATERIAL CODE	OPERATING TEMPERATURE	PROCESSING TEMPERATURE
1, 5, 6, 7	-65°C TO +200°C	CONSULT FACTORY FOR SPECIAL SOLDERING GUIDELINE

**CUSTOMER COPY**



UNLESS OTHERWISE SPECIFIED: DIMENSIONS ARE IN INCHES [MM]	DRAWN	DATE	NAME	
		6/7/2011	JH	
TOLERANCES: ANGULAR: ± 1° DECIMALS .XX = ± .02 [.5] .XXX = ± .005 [.13] .XXXX = ± .0005 [.013]	<small>THE INFORMATION HEREIN CONTAINS PROPRIETARY INFORMATION OF SULLINS ELECTRONICS AND IS NOT TO BE REPRODUCED, USED OR DISCLOSED TO OTHERS FOR ANY PURPOSE EXCEPT AS SPECIFICALLY AUTHORIZED IN WRITING BY AN OFFICER OF SULLINS ELECTRONICS.</small>			TITLE
				EDGE CARD, .156 CC LP
				PART NUMBER
				EMP - - 156 - - DP - - -
	SIZE	CAGE CODE	DWG. NO.	REV
	C	54453	C10666	H
	SCALE: 3:1		SHEET 3 OF 3	