

DWG. NO.
SD-59588-002

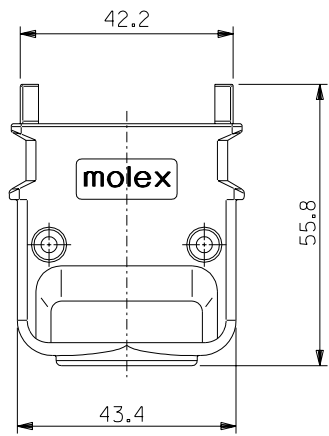
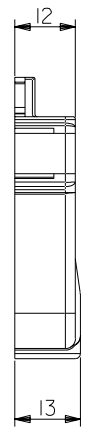
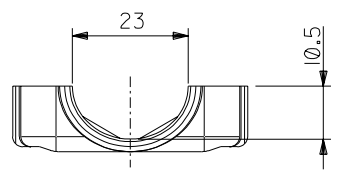
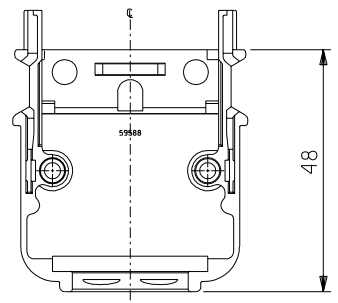
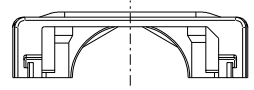

注記
NOTES

1. 材 質
MATERIAL
亜鉛合金、ニッケルメッキ
ZINC ALLOY, NI PLATING
2. 適用プラグカバーA : 59587-5010
APPLICABLE PLUG COVER A : 59587-5010
3. 適合ネジ : 十字穴付きなべ小ネジ (58203-0030)
APPLICABLE SCREW : CROSS RECESSED PAN HEAD MACHINE SCREW (58203-0030)
ネジサイズ : M3X12
SCREW SIZE : M3X12

59588-5000	59588-****
MATERIAL NO.	MODEL NO.

DO NOT SCALE DRAWING

EC NO. DRWN: CHK: APPR:	EC NO. DRWN: CHK: APPR:	EC NO. DRWN: CHK: APPR:	REVISED '02/06/03	MATERIAL 材料	GENERAL TOLERANCES: (UNLESS SPECIFIED) 一般公差	SCALE	DESIGN UNITS <input checked="" type="checkbox"/> mm <input type="checkbox"/> INCH	THIRD ANGLE PROJECTION	DIMENSIONS: <input type="checkbox"/> mm <input type="checkbox"/> INCH <input checked="" type="checkbox"/> mm ONLY	SHT	REV
			EC NO. J2002-3016 DRWN: S.AKIYAMA CHK: J.MIYAZAWA APPR: YO.IITO								
A	0	0	RELEASED '02/02/04	注記参照 SEE NOTES	10 OVER 30 UNDER 以上 未満	±0.25	±0.3	CHECKED BY & DATE <i>J. Mizuno</i> '02/02/04	MATERIAL NO.	DRAWING NO.	SHEET NO.
			EC NO. J2002-1828 DRWN: S.AKIYAMA CHK: J.MIYAZAWA APPR: YO.IITO								
				INS. RANGE 被覆外径	ANGLE 角度	±3°	THIS DRAWING CONTAINS INFORMATION THAT IS PROPRIETARY TO MOLEX INCORPORATED AND SHOULD NOT BE USED WITHOUT WRITTEN PERMISSION.				SIZE B