

THIS DRAWING IS UNPUBLISHED. RELEASED FOR PUBLICATION  
 © COPYRIGHT BY TYCO ELECTRONICS CORPORATION. ALL RIGHTS RESERVED.

| Loc | DIST | REVISIONS |     |                |          |     |      |
|-----|------|-----------|-----|----------------|----------|-----|------|
|     |      | P         | LTR | DESCRIPTION    | DATE     | DWN | APVD |
| H   | -    | E         |     | EH10-0680-05   | 06-06-05 | BSV | BM   |
|     |      | E1        |     | ECR-06-002635  | 07-02-06 | BSV | BM   |
|     |      | F         |     | ECR-06-0026577 | 14-11-06 | BSV | BM   |

### CONNECTOR ASSEMBLY EXEMPLARY LOADED

### CONTACT DIMENSIONS

### RECOMMENDED PCB-HOLE LAY-OUT COMPONENT SIDE SHOWN

### CONTACT LAYOUT

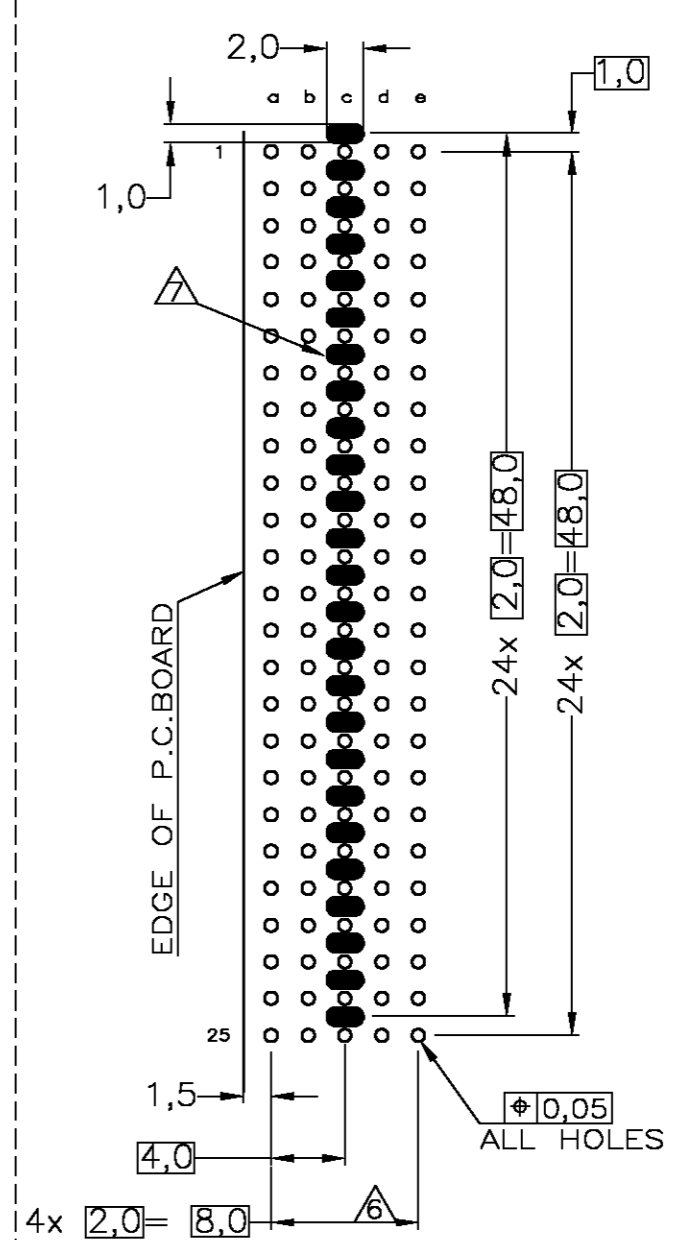
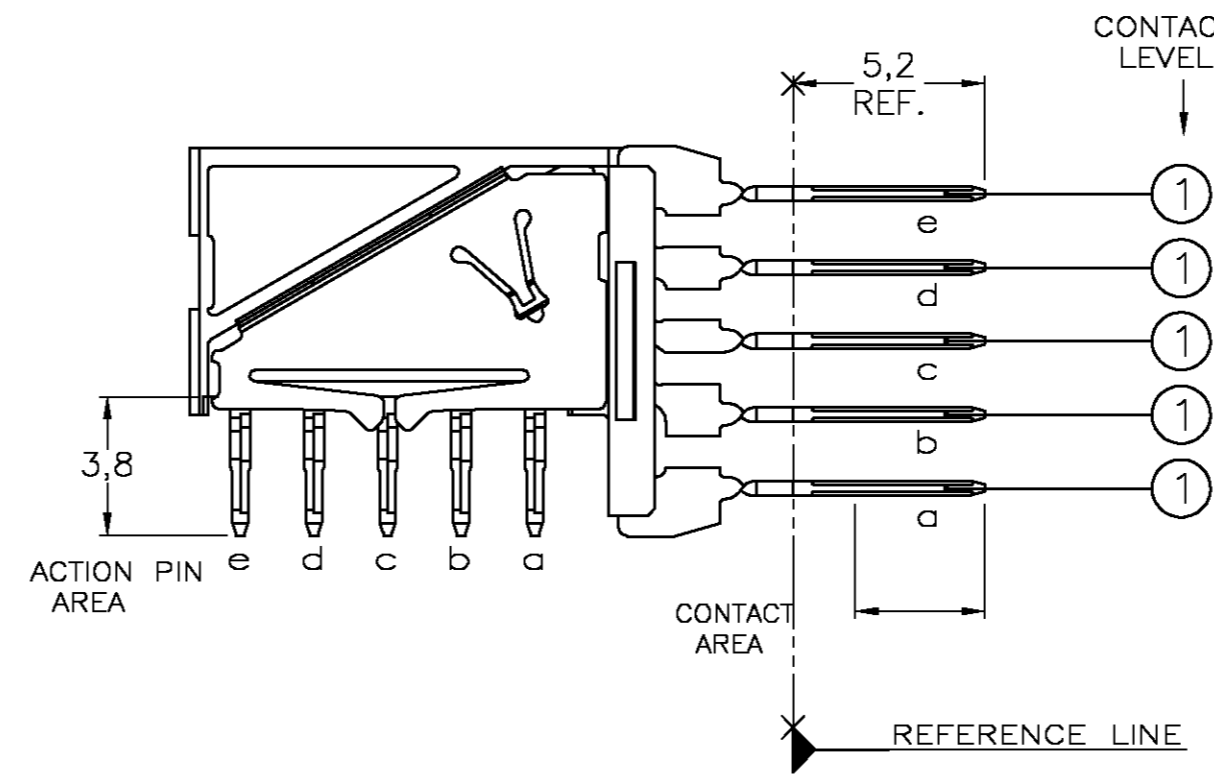
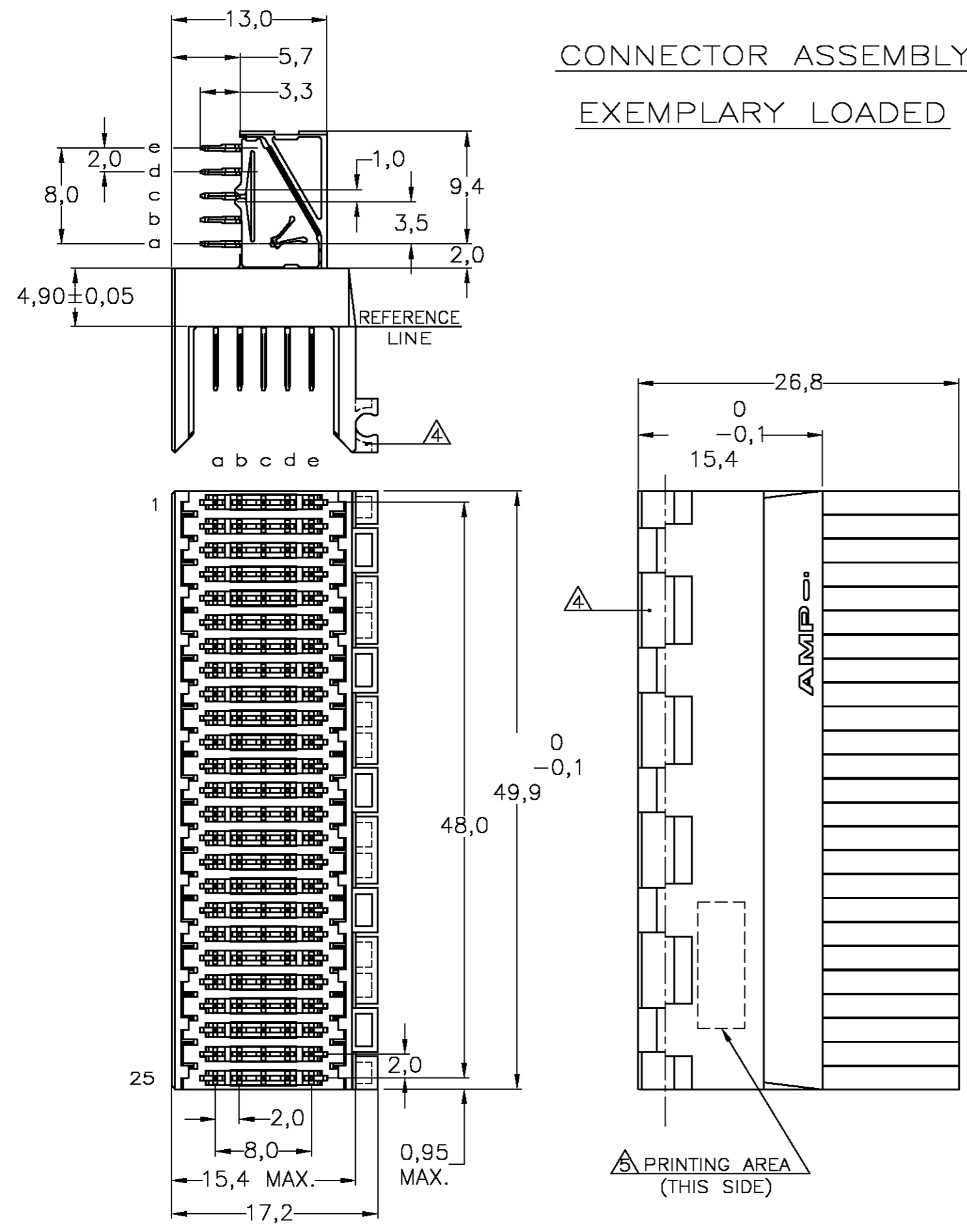

|    | a | b | c | d | e |
|----|---|---|---|---|---|
| 1  | 1 | 1 | 1 | 1 | 1 |
| 2  | 1 | 1 | 1 | 1 | 1 |
| 3  | 1 | 1 | 1 | 1 | 1 |
| 4  | 1 | 1 | 1 | 1 | 1 |
| 5  | 1 | 1 | 1 | 1 | 1 |
| 6  | 1 | 1 | 1 | 1 | 1 |
| 7  | 1 | 1 | 1 | 1 | 1 |
| 8  | 1 | 1 | 1 | 1 | 1 |
| 9  | 1 | 1 | 1 | 1 | 1 |
| 10 | 1 | 1 | 1 | 1 | 1 |
| 11 | 1 | 1 | 1 | 1 | 1 |
| 12 | 1 | 1 | 1 | 1 | 1 |
| 13 | 1 | 1 | 1 | 1 | 1 |
| 14 | 1 | 1 | 1 | 1 | 1 |
| 15 | 1 | 1 | 1 | 1 | 1 |
| 16 | 1 | 1 | 1 | 1 | 1 |
| 17 | 1 | 1 | 1 | 1 | 1 |
| 18 | 1 | 1 | 1 | 1 | 1 |
| 19 | 1 | 1 | 1 | 1 | 1 |
| 20 | 1 | 1 | 1 | 1 | 1 |
| 21 | 1 | 1 | 1 | 1 | 1 |
| 22 | 1 | 1 | 1 | 1 | 1 |
| 23 | 1 | 1 | 1 | 1 | 1 |
| 24 | 1 | 1 | 1 | 1 | 1 |
| 25 | 1 | 1 | 1 | 1 | 1 |

P.C.B. HOLE DIM. ACTION PIN  
FOR DETAILS SEE  
APPLICATION SPECIFICATION

NOTES:

- ① MATERIAL HOUSING : GREY GLASSFILLED POLYESTER  
UL-RATING V0
- ② CONTACT : PHOSPHORBRONZE
- ③ GENERAL CONTACT PLATING SPECIFICATION: UNDERPLATING (ENTIRE CONTACT):  
1,27µm NICKEL MIN. AND ACTION PIN: 0,5µm TIN-LEAD MIN.  
FOR PLATING OF MATING SURFACES SEE APPLICABLE SPECIFICATION  
REFERENCE FOR EACH DASH NUMBER.  
REDUCED CROSS-TALK SHIELD: GOLD FLASH OVER 1,27µm NICKEL MIN.
- ④ CONFORMS TO ALL TESTING ACCORDING IEC 61076-4-101  
PERFORMANCE LEVEL 2.
- ⑤ CONNECTOR ASSEMBLY WITH LATCH HINGE FOR CABLE CONNECTOR.
- ⑥ CONNECTOR PRINTED WITH PARTNUMBER AND DATECODE
- ⑦ PLATED-THROUGH HOLES AT 2x2mm SQUARE GRID.
- ⑧ PLATED SPOT ONLY ON COMPONENT SIDE, FORMING ONE CONTACT  
WITH PLATED THROUGH HOLES OF ROW C

|                |          |            |
|----------------|----------|------------|
| CONTACT FINISH | MATERIAL | 1-352272-1 |
|                |          | 352272-1   |

|  |  |                           |                                     |                               |
|--|--|---------------------------|-------------------------------------|-------------------------------|
| THIS DRAWING IS A CONTROLLED DOCUMENT. |  | DWN L.V.D.HEIJDEN 12FEB98 |                                     | Tyco Electronics Corporation  |
|  |  | CHK D.TRUREN 12FEB98      |                                     | s-Hertogenbosch, Netherlands, |
| DIMENSIONS: mm                         | TOLERANCES UNLESS OTHERWISE SPECIFIED: | APVD F.V.KONINGSBRUGGE    | NAME                                |                               |
| 0 PLC ± -                              | 1 PLC ± -                              | PRODUCT SPEC              | Z-PACK 2MM HM TYPE B                |                               |
| 2 PLC ± -                              | 3 PLC ± -                              | 108-19082                 | 125 POS. RIGHT ANGLE MALE CONNECTOR |                               |
| 4 PLC ± -                              | ANGLES ± -                             | APPLICATION SPEC          | WITH REDUCED CROSS-TALK SHIELDS     |                               |
| MATERIAL                               | FINISH                                 | 114-19029                 | SIZE                                | CAGE CODE                     |
|  |  | WEIGHT                    | A2                                  | 00779                         |
|  |  | CUSTOMER DRAWING          | DRAWING NO. 352272                  |                               |
|  |  |                           | RESTRICTED TO                       |                               |
|  |  |                           | SCALE NTS                           | SHEET 1 OF 1                  |
|  |  |                           |                                     | REV F                         |

352272