

PRODUCT NO	CONDUCTOR POS NO	CONDUCTOR ASSY POS NO	CONTACT PLATING	HOUS'G COLOR
86418-001	4-4	1,2,3,4	5u" Au + high performance lubricant	GRAY
86418-001LF				

LEAD FREE PRODUCT NO.

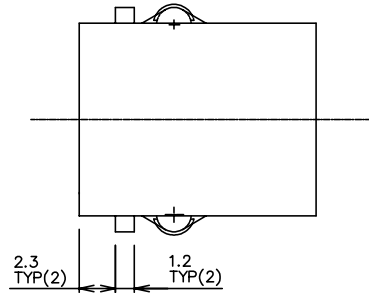
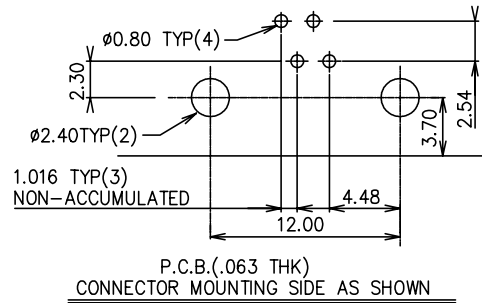

NOTE:

- FOR VISUAL, MECHANICAL AND FUNCTIONAL REQUIREMENTS, SEE PRODUCT SPEC. 110-042.
- HOUSING MAT'L: GLASS REINFORCED 66 NYLON ZYTEL -FR50, UL94V-0.
- GOLD WIRE MAT'L: PHOS. BRONZE 0.46 DIA. PLATING: SEE TABLE
- A. STANDARD PACKAGING METHOD(USE TRAY): SEE GES-14-351.
B. NON-STANDARD PACKAGING METHOD(USE TUBE): SEE GES-14-358. THE PART NO. SHOULD BE SUFFIXED WITH "T" OR "TLF" E.G.86418-001T OR 86418-001TLF
- MATING PLUG: PLUG NEED TO CONFORM TO THE FCC TYPE 616.
- IF LF P/N THE PRODUCT MEETS EUROPEAN UNION DIRECTIVES AND OTHER COUNTRY REGULATIONS AS DESCRIBED IN GS-22-008
- THE HOUSING WILL WITHSTAND EXPOSURE TO 260° PEAK TEMPERATURE FOR 10 SECONDS IN A WAVE SOLDER APPLICATION WITH A 1.60mm MINIMUM THICK CIRCUIT BOARD
- IF LF P/N PACKAGING MEETS GS-14-920 SPECIFICATION

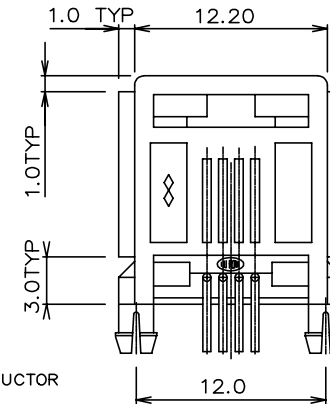
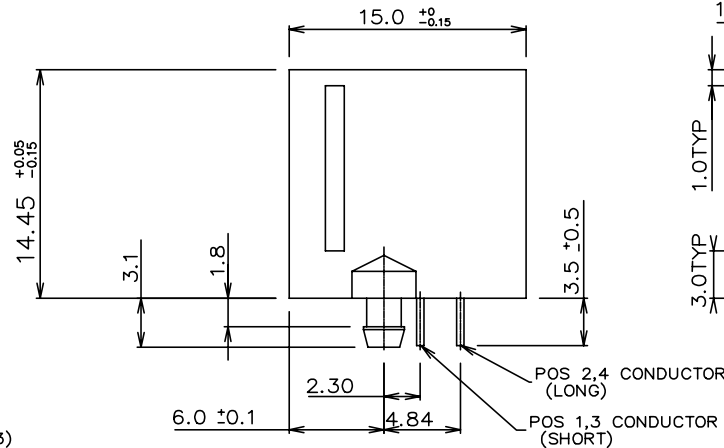
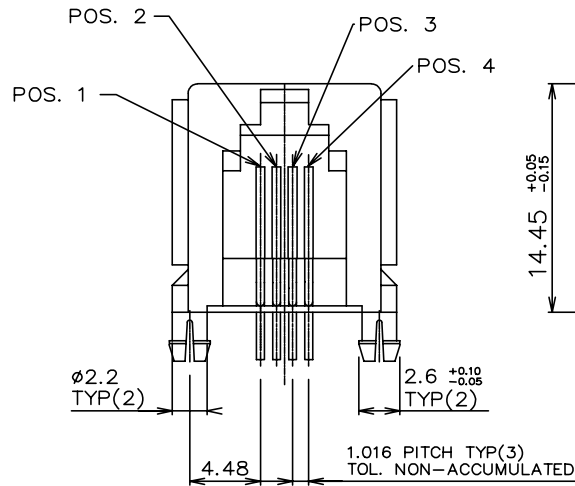

mat'l. code		surface		tolerance		projection		product family	
		ISO1302 ✓		ISO1101 ISO406				MOD JACK	
l	tr	ec	no	dr	date	tolerances unless otherwise specified		title	
D	T60046	CL	02/02/96	angle	0°	mm		LOW PROFILE	
E	T03-0443	WL	10/06/03	0°	0.X±0.3			616PCB MOD JACK	
F	N05-0018	YS	01/25/05	0°±2'	0.XX±0.15	scale:2.0			
G	ELX-N-011019	SH	MM	03/25/12	0°			dwg no	
				KCHOU		11/18/91		sheet 1 of 1	
				engr TONY CHIEN		11/18/91		size	
				chr TONY CHIEN		11/18/91		86418	
				appd JENN TSAO		11/18/91		A4	
sheet		revision		G				type	
index		sheet		1				Product Customer Drawing	