

WTB COAX CONNECTORS

IDC SMT COAX 1 Position 00-9178

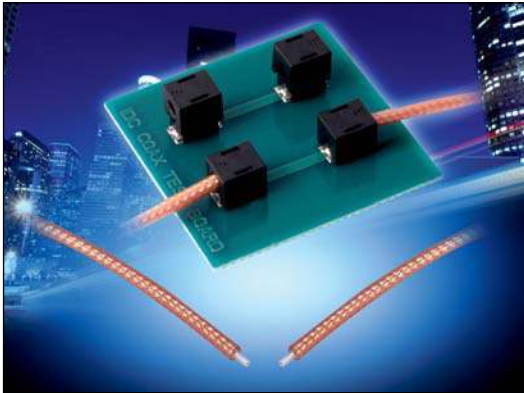

KYOCERA AVX has developed a unique 50 Ohm SMT Coax Connector based on our industry proven discrete wire Insulation Displacement Connector (IDC) technology. By combining two different sized IDC contacts, we can reliably pierce the center conductor and outside jacket dielectric materials to make electrical connection to the signal wire and braid (ground connection). Designed specifically for RG178 cable, the concept can be applied to other cable sizes.

The connector comes with a pre-attached cap in tape & reel packaging. The coax cable only needs the outer jacket and braid stripped. The cable is then inserted into the connector and the cap can be pressed down via a small press or hand tool. The biggest advantage of this connector is that it is extremely easy to terminate, no soldering, additional stripping processes or crimp tools are needed. The all plastic design is more cost effective than plated screw machine components while providing a VSWR less than 1.2:1 in excess of 700MHz.

APPLICATIONS

- Reliable & Repeatable termination of RG178 coax cable to a PCB to replace hard solder connections
- Cost effective replacement of standard coax connectors in low frequency applications for RG178 cable
- Standard Microminiature type RF products: GPS, Radio Boards, Meters, RFID and data communications
- Application notes: refer to 201-01-131

FEATURES AND BENEFITS

- “Gas Tight” IDC termination for long term reliability
- Simple strip, insert and press down termination process
- High temperature endurance testing for 1000 hrs at 125°C
- Industrial operating temperature range for harsh environments

ELECTRICAL

- Current Rating: 0.5A
- (Current limit is cable dependent)
- Voltage Rating: 125V
- VSWR less than 1.2:1 in excess of 700MHz

ENVIRONMENTAL

- Operating Temperature: -40°C to +125°C

MECHANICAL

- Insulator Material: Nylon 46: UL94 V-0
- Contact Material: Phosphor Bronze, Tin Plated
- Latching Cap: Single Use
- Cable retention: 10N in each axis

HOW TO ORDER

00
Prefix

9178
Series

001
Number of Ways

Code	No of Ways	Details
001	1	Page 76

00X
Cable Type

001 = RG178B/U (M17/93-RG178)

X
Contact Plating

Code	Color	Application
0	Black	Industrial
1	White	Lighting

06
Plating Option

06 = Pure Tin all over

WTB COAX CONNECTORS

IDC SMT COAX 1 Position 00-9178

CONNECTOR DETAILS - RG178B/U

CABLE INSERTION DIRECTION
ALSO REFER TO PAGE 77 FOR
PACKING ORIENTATION

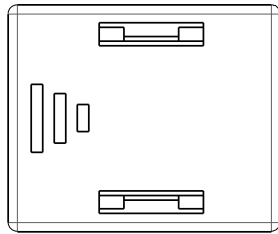

NOTES:

1. CONNECTOR FOR RG178B/U (M17/93-RG178) MIL SPEC COAX CABLE. FOR OTHER CABLES REFER TO KYOCERA AVX FOR FURTHER INFORMATION.
2. FOR FURTHER DETAILS REFER TO ELCO PRODUCT SPECIFICATION 201-01-130 AND APPLICATION NOTES 201-01-131.
3. GENERAL TOLERANCE ± 0.20 UNLESS SPECIFIED.
4. CONNECTOR SUPPLIED AS SHOWN WITH THE CAP IN THE UP POSITION.

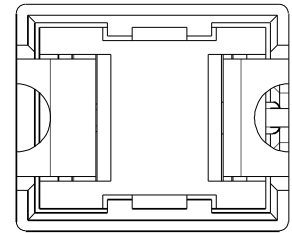
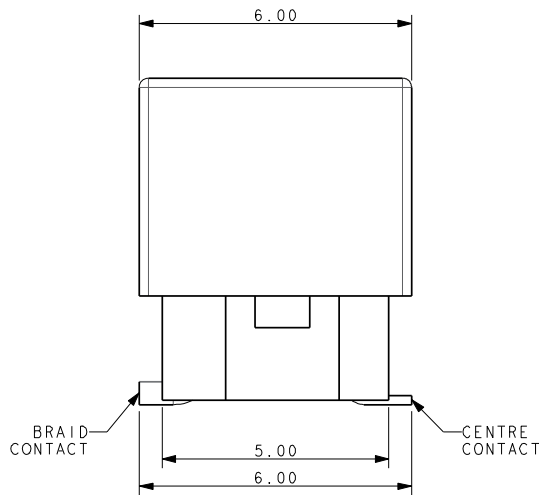
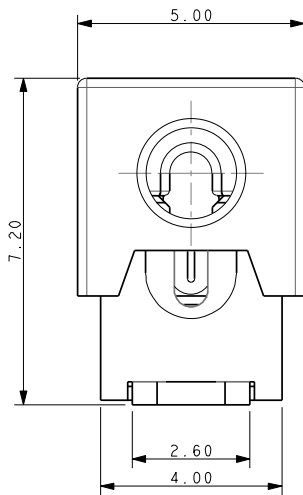

WIRED CONNECTOR

TRIM LENGTH 2.30 ± 0.20
BRAID AND OUTER JACKET ONLY

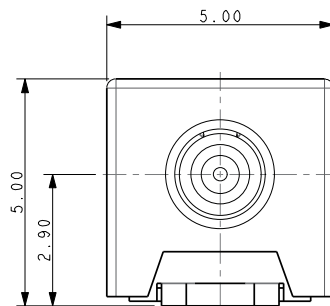

NOTES:

1. CONNECTOR SHOWN IN ASSEMBLED CONDITION, CAP PUSHED DOWN.
2. CAP LOCKS IN LOWER POSITION, TERMINATION CANNOT BE REMADE.
3. FOR FULL DETAILS REFER TO APPLICATION NOTES 201-01-131.
4. CONNECTOR FOR RG178B/U (M17/93-RG178) MIL SPEC COAX CABLE ONLY.
5. ALL LOOSE MATERIAL MUST BE REMOVED FROM TRIMMED CABLE.

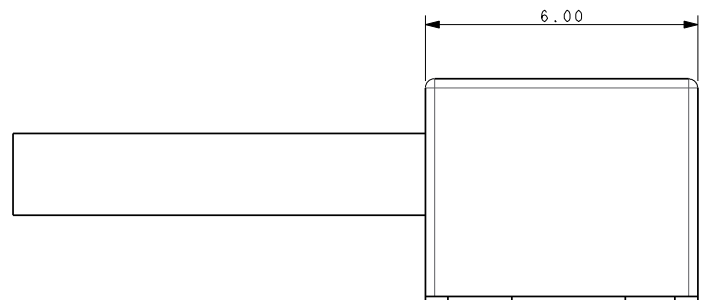
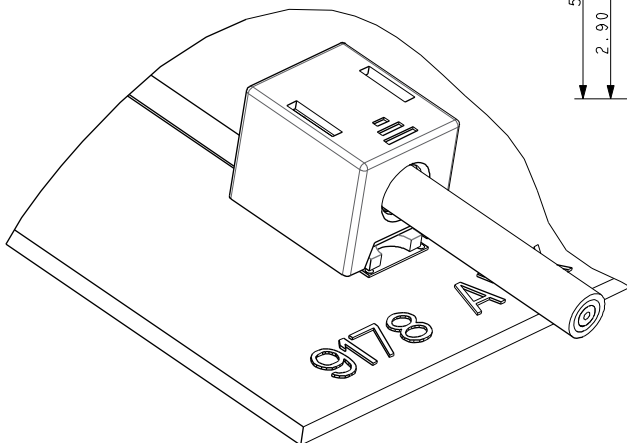

SUGGESTED PCB LAYOUT

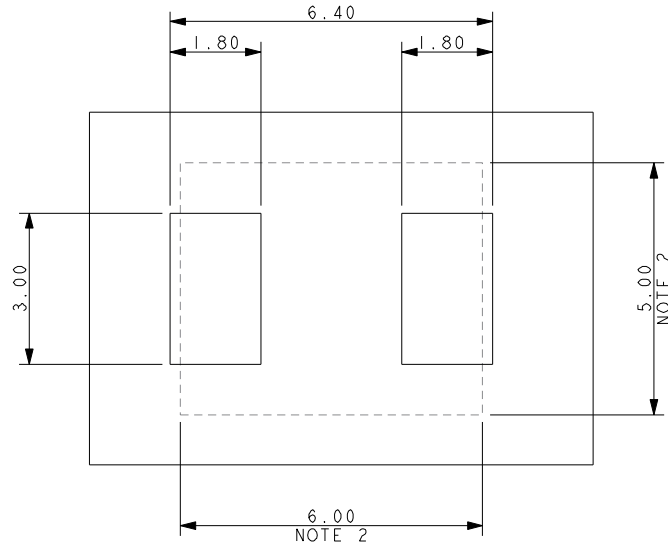

NOTES:

1. PADS SHOWN FOR CONNECTOR FEET ONLY, OTHER DETAILS WILL DEPEND ON THE CUSTOMERS PCB SPECIFICATION AND PERFORMANCE REQUIREMENTS.
2. OUTLINE OF THE CONNECTOR.
3. TYPICAL CIRCUIT CONFIGURATION:
4. BRAID CONNECTED THROUGH BOARD TO GROUND PLANE. CENTER CONDUCTOR TRACK 1.5MM WIDE ON 0.8MM THICK PCB

PACKING DETAILS

REEL QTY	700
LEADER	480MM
TRAILER	120MM

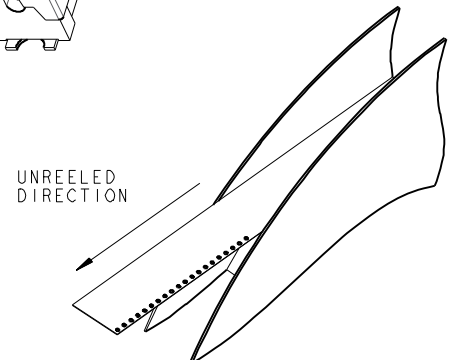
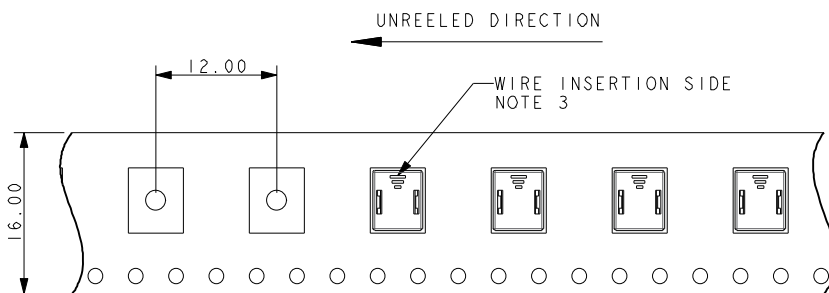
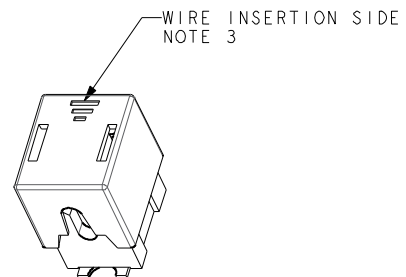

NOTES:

1. PACKING IN TAPE AND REEL.
2. PIECES PER REEL.
3. PARTS TO BE IN THE CORRECT ORIENTATION.

WTB COAX CONNECTORS

IDC SMT COAX 1 Position 00-9178

HAND ASSEMBLY TOOL

