

## High Performance LVPECL Fanout Buffer

### Features

- 4 LVPECL outputs
- Up to 1.5GHz output frequency
- Ultra low additive phase jitter: < 0.04 ps (typ)
- Two selectable inputs
- Low delay from input to output (T<sub>pd</sub> typ. < 1.0ns)
- 2.5V / 3.3V power supply
- Industrial temperature support
- TSSOP-20 package

### Description

The PI6C4911504-01 is a high performance fanout buffer device which supports up to 1.5GHz frequency. This device is ideal for systems that need to distribute low jitter clock signals to multiple destinations.

### Applications

- Networking systems including switches and Routers
- High frequency backplane based computing and telecom platforms

### Block Diagram

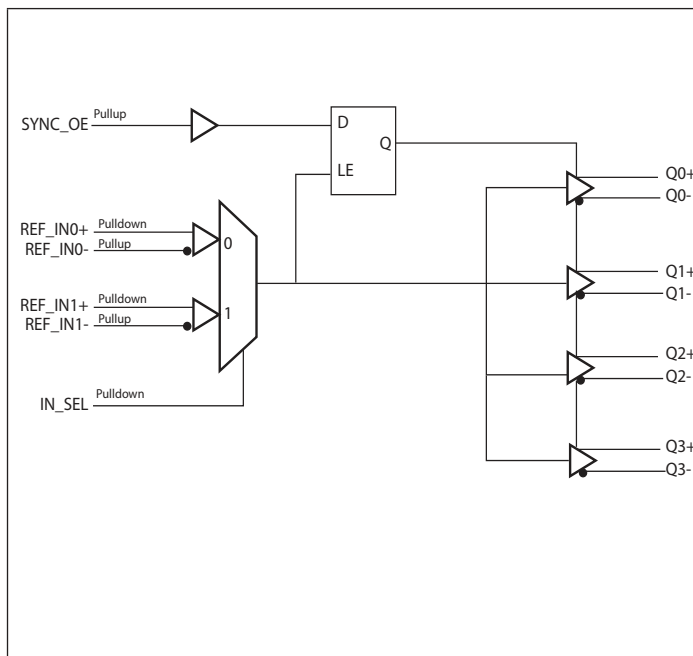

### Pin Configuration (20-Pin TSSOP)

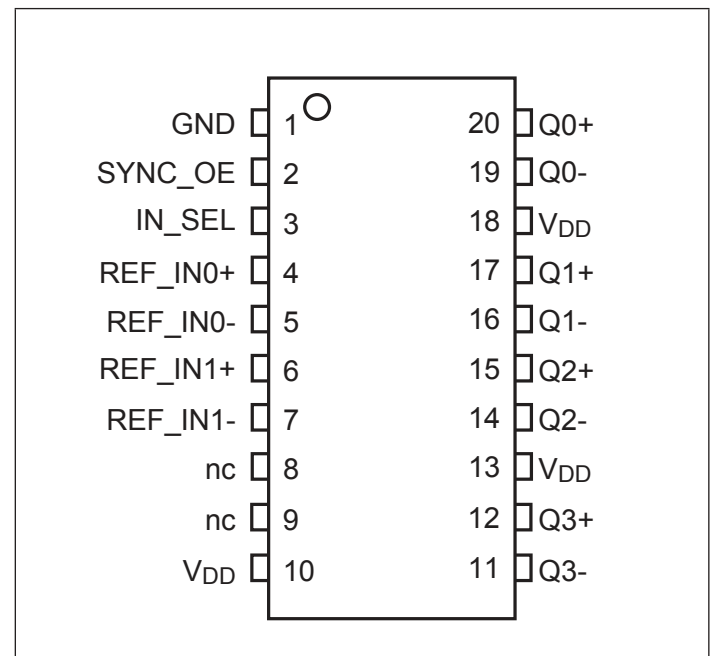

## Pinout Table

Pin #	Pin Name	Type		Description
1	GND	Power		Ground
2	SYNC_OE	Input	Pullup	Synchronous clock enable. When High, clock outputs follow REF_IN. When low, Q+ outputs are forced low, Q- are forced high
3	IN_SEL	Input	Pulldown	Clock input source selection pin
4, 5	REF_IN0+ REF_IN0-	Input	Pulldown Pullup	Differential clock input 0
6, 7	REF_IN1+ REF_IN1-	Input	Pulldown Pullup	Differential clock input 1
8, 9	NC	-		No connect
10, 13, 18	V <sub>DD</sub>	Power		Power supply
11, 12	Q3+ Q3-	Output		LVPECL output clock 3
14, 15	Q2+ Q2-	Output		LVPECL output clock 2
16, 17	Q1+ Q1-	Output		LVPECL output clock 1
19, 20	Q0+ Q0-	Output		LVPECL output clock 0

## Function Table

Table 1: Clock source input select function

IN_SEL	Function
0	REF_IN0 is the selected reference input
1	REF_IN1 is the selected reference input

Table 2: SYNC\_OE select function

SYNC_OE	Function
0	All outputs disabled. Q+ disabled low, Q- disabled High.
1	All outputs enabled.

## Pin Characteristics

Symbol	Parameter	Min	Typ	Max	Units
R <sub>PULLUP</sub>	Input Pullup Resistor		50		kΩ
R <sub>PULLDOWN</sub>	Input Pulldown Resistor		75		kΩ

**Maximum Ratings** (Above which the useful life may be impaired. For user guidelines, not tested)

Storage temperature.....	-55 to +150°C
Supply Voltage to Ground Potential ( $V_{DD}$ ).....	-0.5 to +4.65V
Inputs (Referenced to GND) .....	-0.5 to $V_{DD}+0.5V$
Clock Output (Referenced to GND).....	-0.5 to $V_{DD}+0.5V$
Soldering Temperature (Max of 10 seconds) .....	+260°C
Latch up .....	200mA
ESD Protection (Input) .....	2000 V min (HBM)

**Note:**

Stresses greater than those listed under MAXIMUM RATINGS may cause permanent damage to the device. This is a stress rating only and functional operation of the device at these or any other conditions above those indicated in the operational sections of this specification is not implied. Exposure to absolute maximum rating conditions for extended periods may affect reliability.

**Power Supply Characteristics and Operating Conditions**

Symbol	Parameter	Test Condition	Min.	Typ.	Max.	Units
$V_{DD}$	Supply Voltage		3.135		3.465	V
			2.375		2.625	V
$I_{DD}$	Power Supply Current	Outputs unloaded			90	mA
$T_A$	Ambient Operating Temperature		-40		85	°C

**LVCMOS/ LVTTTL DC Characteristics**

Symbol	Parameter	Test Condition	Min.	Typ.	Max.	Units
$V_{IH}$	Input High Voltage	$V_{DD} = V_{IN} = 3.465V$	2		$V_{DD}+0.3$	V
		$V_{DD} = V_{IN} = 2.625V$	1.6		$V_{DD}+0.3$	V
$V_{IL}$	Input Low Voltage	$V_{DD} = V_{IN} = 3.465V$	-0.3		0.8	V
		$V_{DD} = V_{IN} = 2.625V$	-0.3		0.6	V
$I_{IH}$	Input High Current	SYNC_OE	$V_{DD} = V_{IN} = 3.465V$		5	$\mu A$
			$V_{DD} = V_{IN} = 2.625V$		5	
		IN_SEL	$V_{DD} = V_{IN} = 3.465V$		150	$\mu A$
			$V_{DD} = V_{IN} = 2.625V$		150	
$I_{IL}$	Input Low Current	SYNC_OE	$V_{DD} = V_{IN} = 3.465V$	-150		$\mu A$
			$V_{DD} = V_{IN} = 2.625V$	-150		
		IN_SEL	$V_{DD} = V_{IN} = 3.465V$	-5		$\mu A$
			$V_{DD} = V_{IN} = 2.625V$	-5		

**DC Electrical Specifications - Differential Inputs**

Symbol	Parameter		Min.	Typ.	Max.	Units
I <sub>IH</sub>	Input High current	REF_IN-	Input = V <sub>DD</sub>		5	μA
		REF_IN+	Input = V <sub>DD</sub>		150	μA
I <sub>IL</sub>	Input Low current	REF_IN-	Input = GND	-150		μA
		REF_IN+	Input = GND	-5		μA
V <sub>ID</sub>	Input Differential Amplitude (V <sub>p-p</sub> )		0.15		V <sub>DD</sub> -2.0	V
V <sub>CM</sub>	Common mode input voltage	REF_IN0	0.5		V <sub>DD</sub> -0.85	V
		REF_IN1	1.5		V <sub>DD</sub>	

**DC Electrical Specifications- LVPECL Outputs**

Parameter	Description	Conditions	Min.	Typ.	Max.	Units
V <sub>OH</sub>	Output High voltage	V <sub>DD</sub> = 3.3V ± 5%	V <sub>DD</sub> -1.4		V <sub>DD</sub> -0.9	V
		V <sub>DD</sub> = 2.5V ± 5%	V <sub>DD</sub> -1.6		V <sub>DD</sub> -0.8	V
V <sub>OL</sub>	Output Low voltage	V <sub>DD</sub> = 3.3V ± 5%	V <sub>DD</sub> -2.0		V <sub>DD</sub> -1.6	V
		V <sub>DD</sub> = 2.5V ± 5%	V <sub>DD</sub> -2.0		V <sub>DD</sub> -1.5	V

**AC Electrical Specifications – Differential Outputs**

Parameter	Description	Conditions	Min.	Typ.	Max.	Units
F <sub>OUT</sub>	Clock output frequency	LVPECL			1500	MHz
T <sub>r</sub>	Output rise time	From 20% to 80%	300	400	600	ps
T <sub>f</sub>	Output fall time	From 80% to 20%	300	400	600	ps
T <sub>ODC</sub>	Output duty cycle	Frequency<650MHz	48		52	%
V <sub>PP</sub>	Output swing Single-ended	Frequency<650MHz	400			
T <sub>addjitter</sub>	Buffer additive jitter RMS	Using 156.25MHz XO, 0.17ps jitter as source @3.3V		0.05		ps
T <sub>Phasejitter</sub>	Total output jitter RMS	Using 156.25MHz XO, 0.17ps jitter as source @3.3V			0.23	ps
T <sub>SK</sub>	Output Skew	4 outputs devices, outputs in same tank, with same load, at DUT.		40		ps
T <sub>PD</sub>	Propagation Delay			1000		ps
T <sub>OD</sub>	Valid to HiZ		100			ns
T <sub>OE</sub>	HiZ to valid		100			ns

**Notes:**

1. This parameter is guaranteed by design

**Phase Noise Plots**

$f_{OUT} = 156.25\text{MHz}$

Output phase noise (Dark Blue) vs Input Phase noise (light blue)

Additive jitter is calculated at 156.25MHz~40fs RMS (12kHz to 20MHz). Additive jitter =  $\sqrt{(\text{Output jitter}^2 - \text{Input jitter}^2)}$

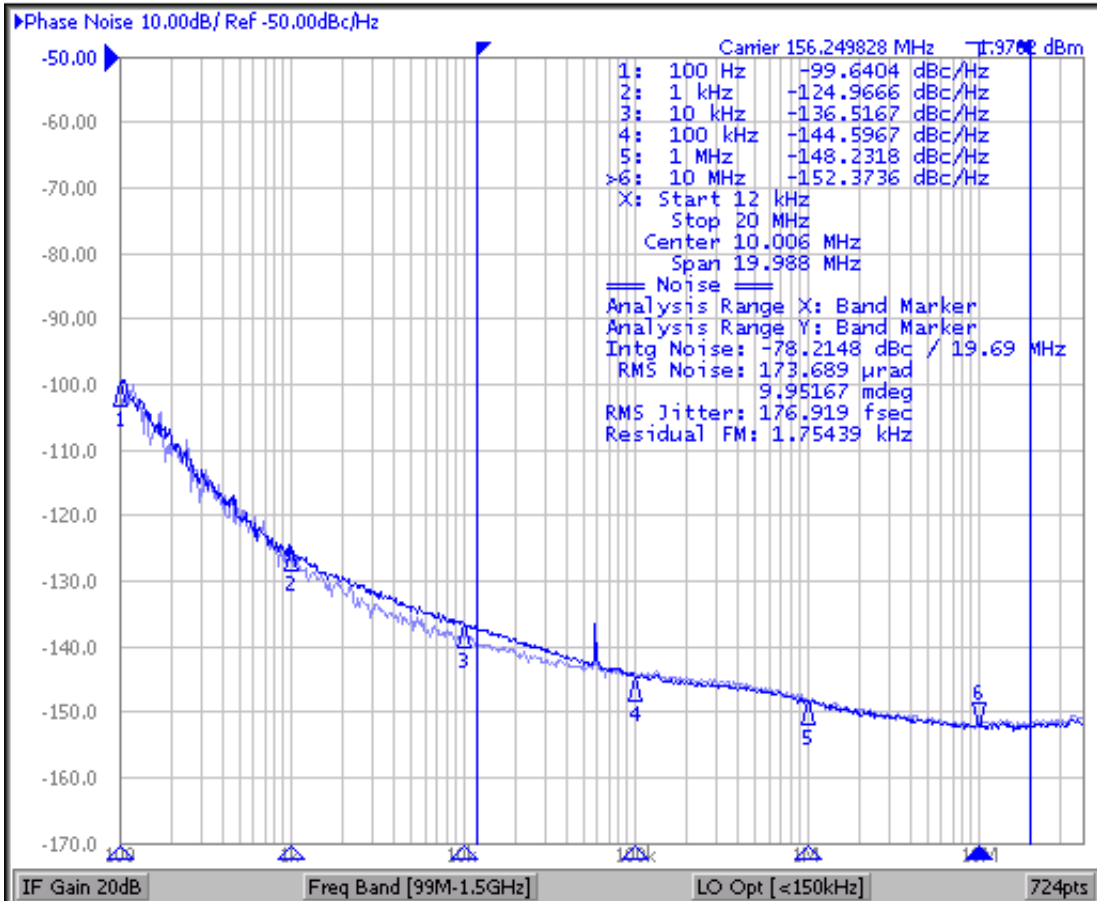

**Configuration Test Load Board Termination for LVPECL**

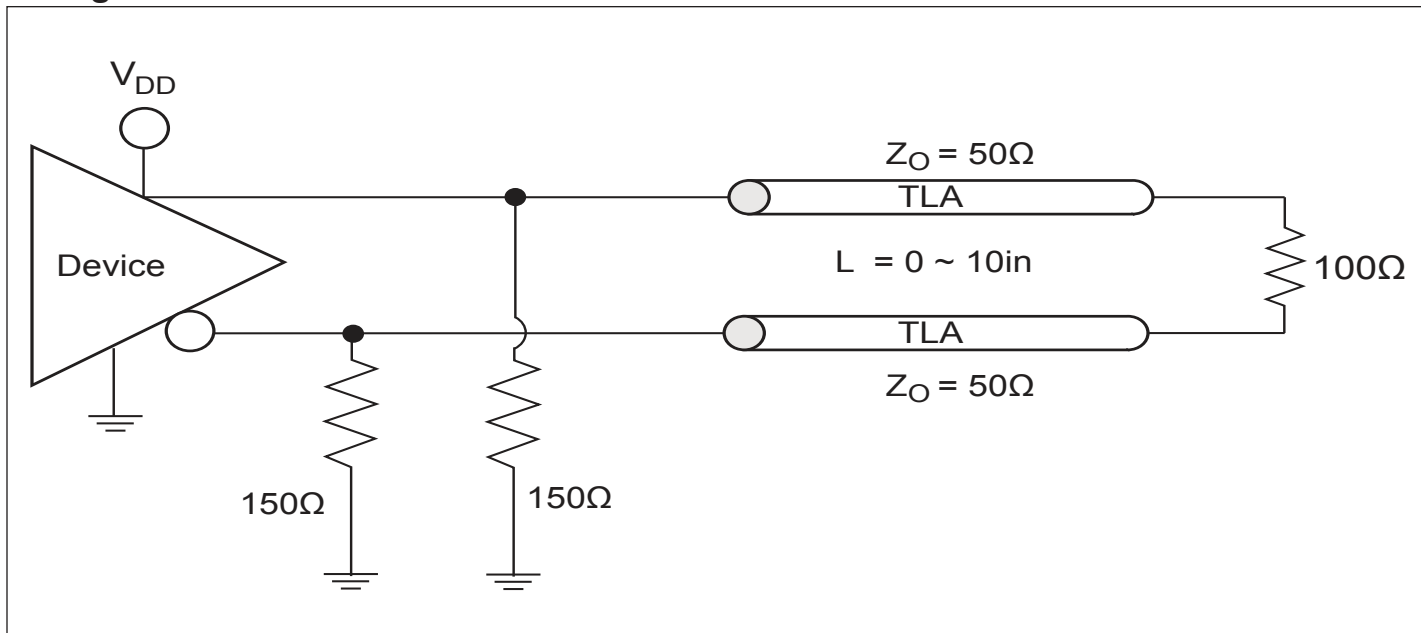

**Application information**

**Suggest for Unused Inputs and Outputs**

**LVC MOS Input Control Pins**

It is suggested to add pull-up=4.7k and pull-down=1k for LVC-MOS pins even though they have internal pull-up/down but with much higher value (>=50k) for higher reliability design.

**Differential +IN/-IN Input Pins**

They can be left floating if not used. Connect them 1k to GND is optional for the additional protection.

**Outputs**

All unused outputs are suggested to be left open and not connected to any trace. This can lower the IC power supply power.

**Power Decoupling & Routing**

**VDD Pin Decoupling**

As general design rule, each VDD pin must have a 0.1uF decoupling capacitor. For better decoupling, 1uF can be used. Locating the decoupling capacitor on the component side has better decoupling filter result as shown below.

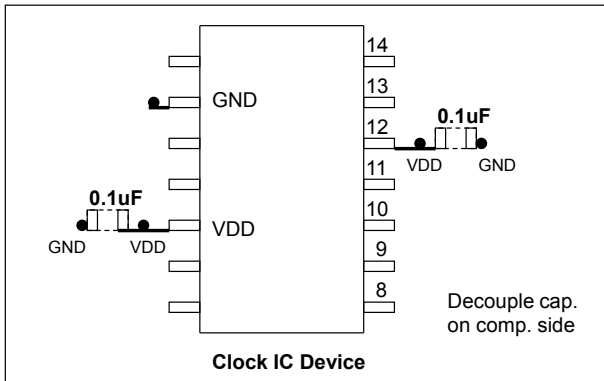

Placement of Decoupling caps

**Differential Clock Trace Routing**

Always route differential signals symmetrically, make sure there is enough keep-out space to the adjacent trace (>20mil.). In 156.25MHz XO drives IC example, it is better routing differential trace on component side as the following.

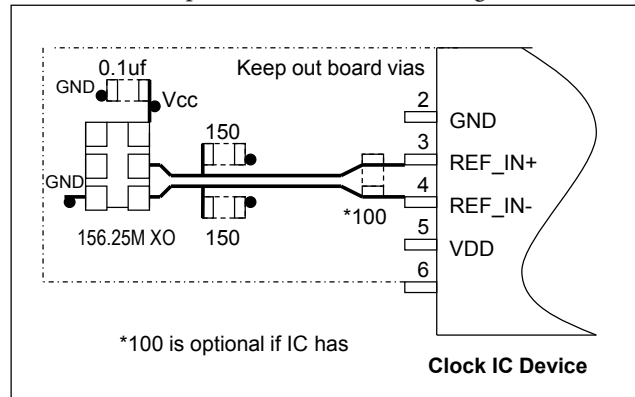

IC routing for XO drive

Clock timing is the most important component in PCB design, so its trace routing must be planned and routed as a first priority in manual routing. Some good practices are to use minimum vias (total trace vias count <4), use independent layers with good reference plane and keep other signal traces away from clock traces (>20mil.) etc.

**LVPECL and LVDS Input Interface**

**LVPECL and LVDS DC/ AC Input**

LVPECL and LVDS clock input to this IC is connected as shown below.

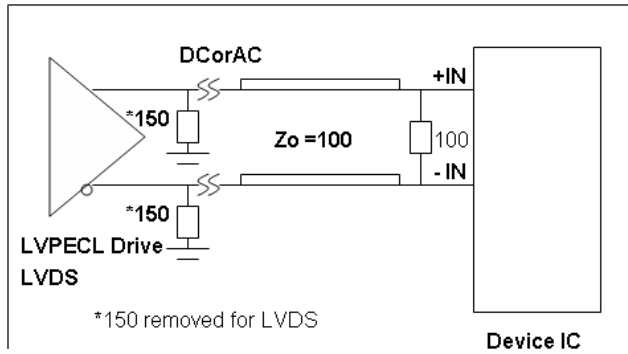

LVPECL/ LVDS Input

**CMOS Clock DC Drive Input**

LVC MOS clock has voltage  $V_{oh}$  levels such as 3.3V, 2.5V, 1.8V. CMOS drive requires a  $V_{cm}$  design at the input:  $V_{cm} = \frac{1}{2}$  (CMOS  $V$ ) as shown below.  $R_s = 22 \sim 33\text{ohm}$  typically.

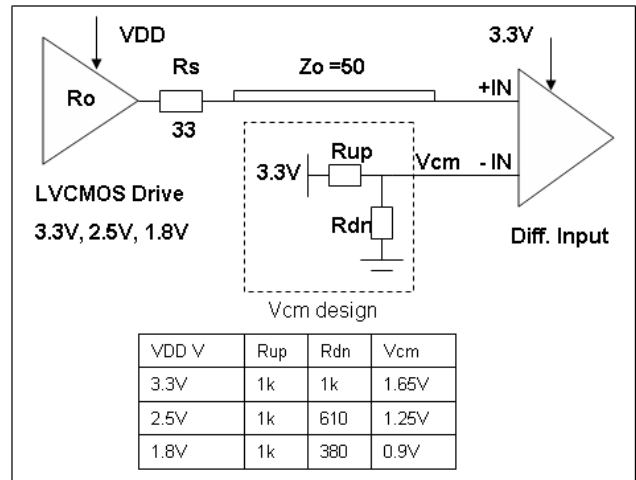

CMOS DC Input Vcm Design



**Device LVPECL Output Terminations**

**LVPECL Output Popular Termination**

The most popular LVPECL termination is 150ohm pull-down bias and 100ohm across at RX side. Please consult ASIC data-sheet if it already has 100ohm or equivalent internal termination. If so, do not connect external 100ohm across as shown in below. This popular termination's advantage is that it does not allow any bias through from Vcc. This prevents Vcc system noise coupling onto clock trace.

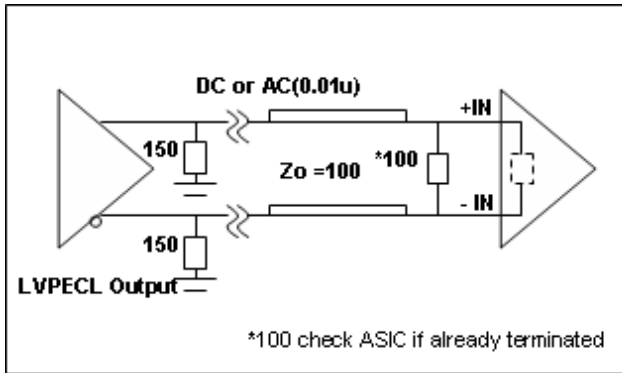

LVPECL Output Popular Termination

**LVPECL Output Thevenin Termination**

Figure below shows LVPECL output Thevenin termination which is used for shorter trace drive (<5in.), but it takes Vcc bias current and Vcc noise can get onto clock trace. It also requires more component count. So it is seldom used today.

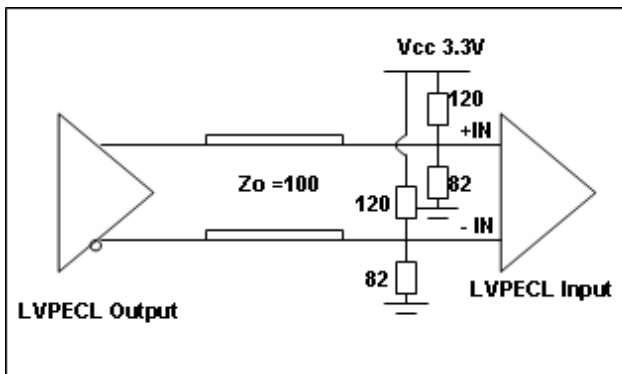

LVPECL Thevenin Output Termination

**LVPECL Output AC Thevenin Termination**

LVPECL AC Thevenin terminations require a 150ohm pull-down before the AC coupling capacitor at the source as shown below. Note that pull-up/down resistor value is swapped compared to previous figure. This circuit is good for short trace (<5in.) application only.

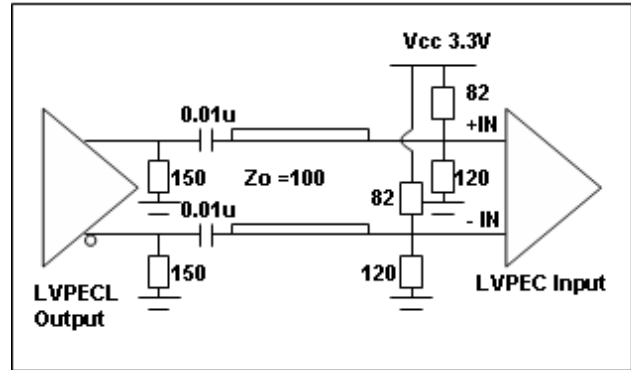

LVPECL Output AC Thevenin Termination

**LVPECL Output Drive HCSL Input**

Using the LVPECL output to drive a HCSL input can be done using a typical LVPECL AC Thevenin termination scheme. Use pull-up/down 450/60ohm to generate Vcm=0.4V for the HCSL input clock. This termination is equivalent to 50Ohm load as shown.

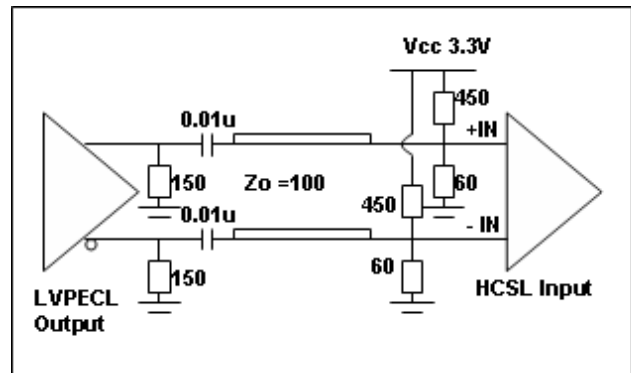

LVPECL Output Drive HCSL Termination

**LVPECL Output V<sub>swing</sub> Adjustment**

It is suggested to add another cross 100ohm at TX side to tune the LVPECL output V<sub>swing</sub> without changing the optimal 150ohm pull-down bias. This form of double termination can reduce the V<sub>swing</sub> in 1/2 of the original at the RX side. By fine tuning the 100ohm resistor at the TX side with larger values like 150 to 200ohm, one can increase the V<sub>swing</sub> by > 1/2 ratio.

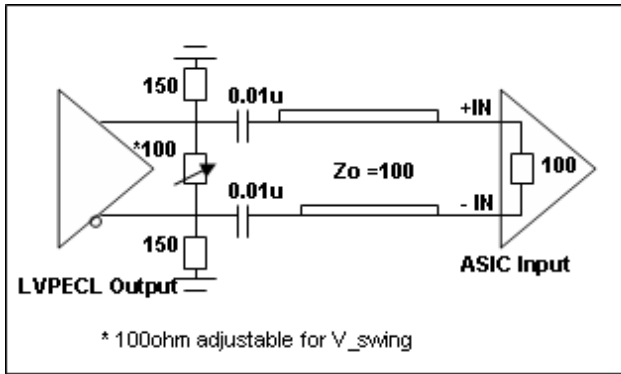

LVPECL Output V<sub>swing</sub> Adjustment

**LVPECL V<sub>swing</sub> Adjustment using Rs**

Another way to control V<sub>swing</sub> is by adding serial Rs. Rs value is tunable between 22 to 33 ohm depending on application. This method may reduce the clock drive PCB trace in slower Tr/Tf.

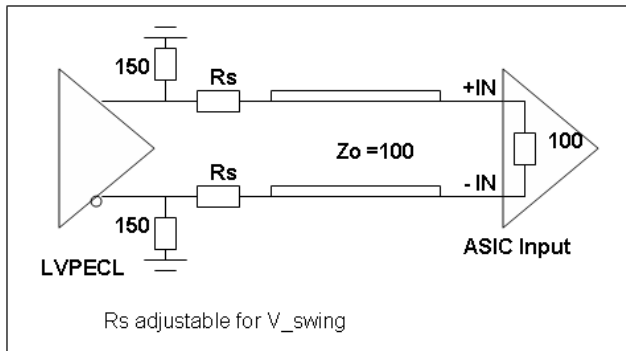

LVPECL V<sub>swing</sub> Adjustment using Rs

**Clock Jitter Definitions**

**Total jitter= RJ + DJ**

Random Jitter (RJ) is unpredictable and unbounded timing noise that can fit in a Gaussian math distribution in RMS. RJ test values are directly related with how long or how many test samples are available. Deterministic Jitter (DJ) is timing jitter that is predictable and periodic in fixed interference frequency. Total Jitter (TJ) is the combination of random jitter and deterministic jitter:  $TJ = \sqrt{RJ^2 + DJ^2}$ , where  $K$  is a factor based on total test sample count. JEDEC std. specifies digital clock TJ in 10k random samples.

**Phase Jitter**

Phase noise is short-term random noise attached on the clock carrier and it is a function of the clock offset from the carrier, for example dBc/Hz@10kHz which is phase noise power in 1-Hz normalized bandwidth vs. the carrier power @10kHz offset. Integration of phase noise in plot over a given frequency band yields RMS phase jitter, for example, to specify phase jitter <=1ps at 12k to 20MHz offset band as SONET standard specification.

**PCIe Ref\_CLK Jitter**

PCIe reference clock jitter specification requires testing via the PCI-SIG jitter tool, which is regulated by US PCI-SIG organization. The jitter tool has PCIe Serdes embedded filter to calculate the equivalent jitter that relates to data link eye closure. Direct peak-peak jitter or phase jitter test data, normally is higher than jitter measure using PCI-SIG jitter tool. It has high-frequency jitter and low-frequency jitter spec. limit. For more information, please refer to the PCI-SIG website: <http://www.pcisig.com/specifications/pciepress/>

**Device Thermal Calculation**

Figure below shows the JEDEC thermal model in a 4-layer PCB.

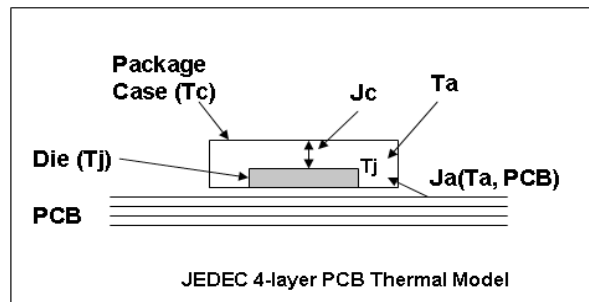

JEDEC IC Thermal Model

Important factors to influence device operating temperature are:

- 1) The power dissipation from the chip (P<sub>chip</sub>) is after subtracting power dissipation from external loads. Generally it can be the no-load device I<sub>dd</sub>
- 2) Package type and PCB stack-up structure, for example, 1oz 4 layer board. PCB with more layers and are thicker has better heat dissipation

3) Chassis air flow and cooling mechanism. More air flow M/s and adding heat sink on device can reduce device final die junction temperature Tj

The individual device thermal calculation formula:

$$T_j = T_a + P_{chip} \times J_a$$

$$T_c = T_j - P_{chip} \times J_c$$

J<sub>a</sub> \_\_\_ Package thermal resistance from die to the ambient air in C/W unit; This data is provided in JEDEC model simulation. An air flow of 1m/s will reduce J<sub>a</sub> (still air) by 20~30%

J<sub>c</sub> \_\_\_ Package thermal resistance from die to the package case in C/W unit

T<sub>j</sub> \_\_\_ Die junction temperature in C (industry limit <125C max.)

T<sub>a</sub> \_\_\_ Ambient air temperature in C

T<sub>c</sub> \_\_\_ Package case temperature in C

P<sub>chip</sub> \_\_\_ IC actually consumes power through I<sub>ee</sub>/GND current

### Thermal calculation example

To calculate T<sub>j</sub> and T<sub>c</sub> of PI6CV304 in an SOIC-8 package:

Step 1: Go to Pericom web to find J<sub>a</sub>=157 C/W, J<sub>c</sub>=42 C/W

<http://www.pericom.com/support/packaging/packaging-mechanicals-and-thermal-characteristics/>

Step 2: Go to device datasheet to find I<sub>dd</sub>=40mA max.

I <sub>DD</sub>	Supply Current	C <sub>L</sub> = 33pF/33MHz	20	mA
		C <sub>L</sub> = 33pF/60MHz	40	
		C <sub>L</sub> = 22pF/80MHz	35	
		C <sub>L</sub> = 15pF/100MHz	32	
		C <sub>L</sub> = 10pF/125MHz	28	
		C <sub>L</sub> = 10pF/155MHz	41	

Step 3: P<sub>total</sub> = 3.3Vx40mA=0.132W

Step 4: If T<sub>a</sub>=85C

$$T_j = 85 + J_a \times P_{total} = 85 + 25.9 = 105.7C$$

$$T_c = T_j + J_c \times P_{total} = 105.7 - 5.54 = 100.1C$$

Note:

The above calculation is directly using I<sub>dd</sub> current without subtracting the load power, so it is a conservative estimation. For more precise thermal calculation, use P<sub>unload</sub> or P<sub>chip</sub> from device I<sub>ee</sub> or GND current to calculate T<sub>j</sub>, especially for LVPECL buffer ICs that have a 150ohm pull-down and equivalent 100ohm differential RX load.

## Thermal Information

Symbol	Description	Condition	
Θ <sub>JA</sub>	Junction-to-ambient thermal resistance	Still air	84.0 °C/W
Θ <sub>JC</sub>	Junction-to-case thermal resistance		17.0 °C/W

**Packaging Mechanical: 20-Contact TSSOP (L)**

DOCUMENT CONTROL NO.  
PD - 1311

REVISION: E  
DATE: 03/09/05

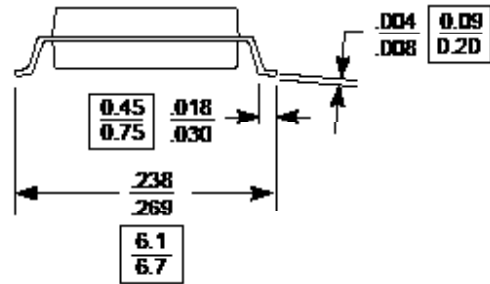
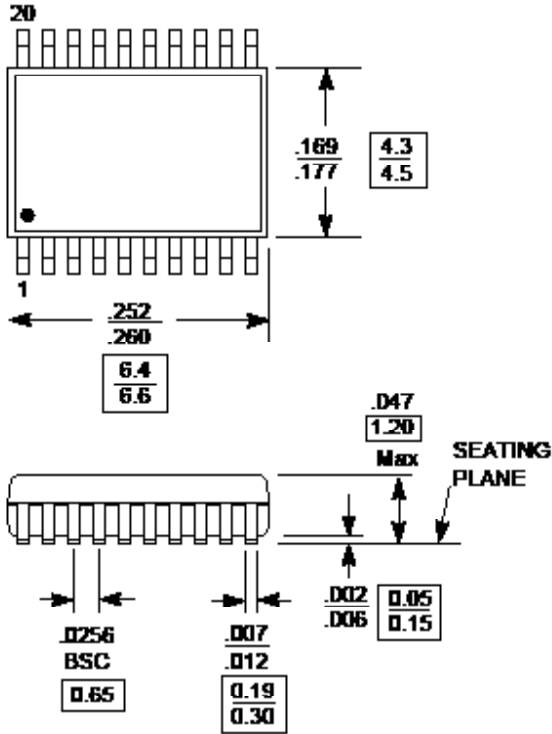

- Note:
1. Package Outline Exclusive of Mold Flash and Metal Burr
  2. Controlling dimensions in millimeters
  3. Ref. JEDEC MO-153F1AG



Pericom Semiconductor Corporation  
3545 N. 1st Street, San Jose, CA 95134  
1-800-435-2336 • www.pericom.com

DESCRIPTION: 20-Pin, 173-Mil Wide, TSSOP

PACKAGE CODE: L

**Ordering Information**

Ordering Number	Package Code	Package Description	Operating Temperature
PI6C4911504-01LIE	L	Pb-free & Green 20-Contact TSSOP	-40 to 85 °C

- Thermal characteristics can be found on the company web site at [www.pericom.com/packaging/](http://www.pericom.com/packaging/)
- E = Pb-free and Green
- X suffix = Tape/Reel