

PART NUMBER	REV	FIRST USED
680275-1	B	122500-1
680275-2	B	565435-5
680275-3	B	354500-1

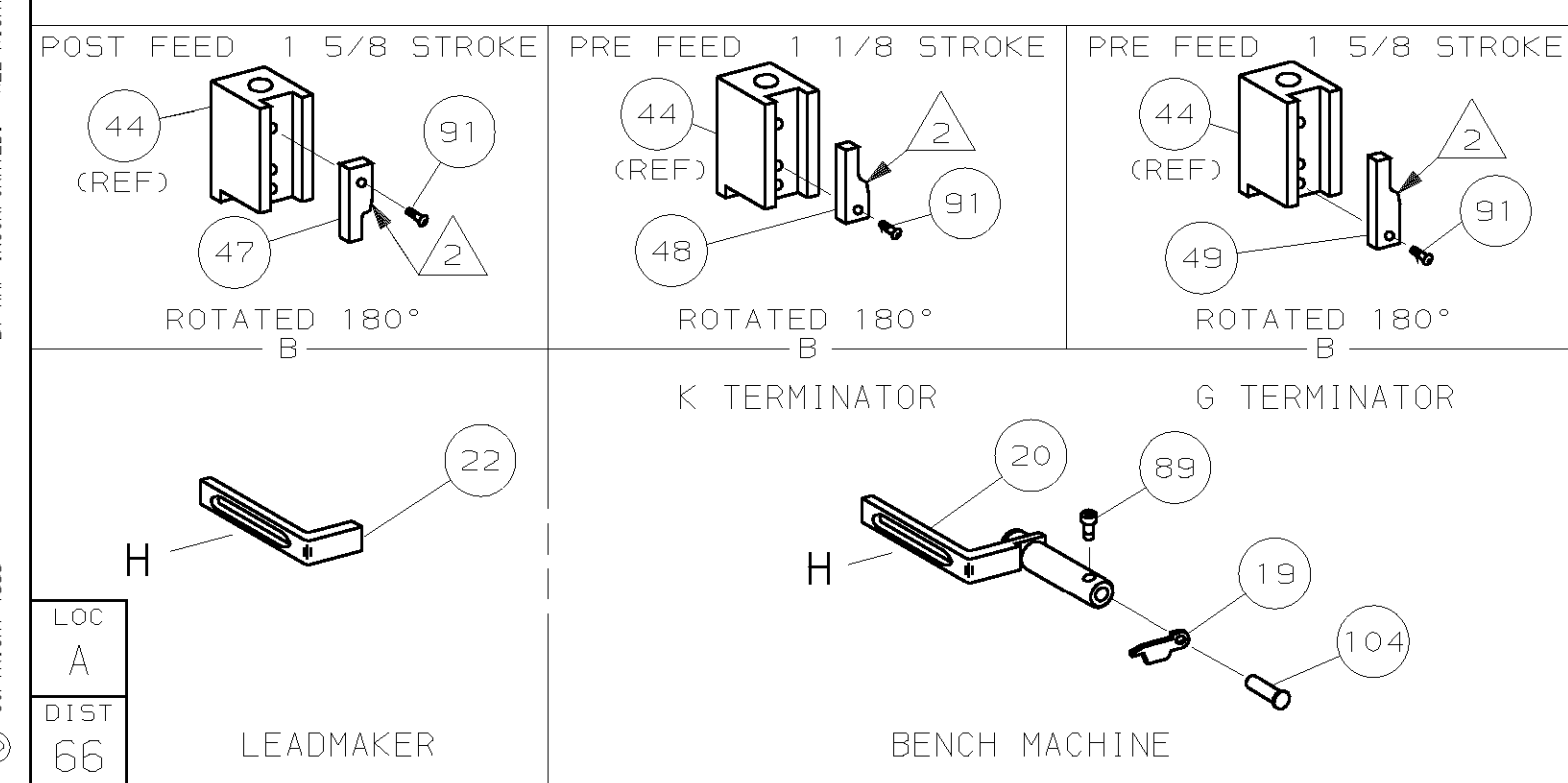
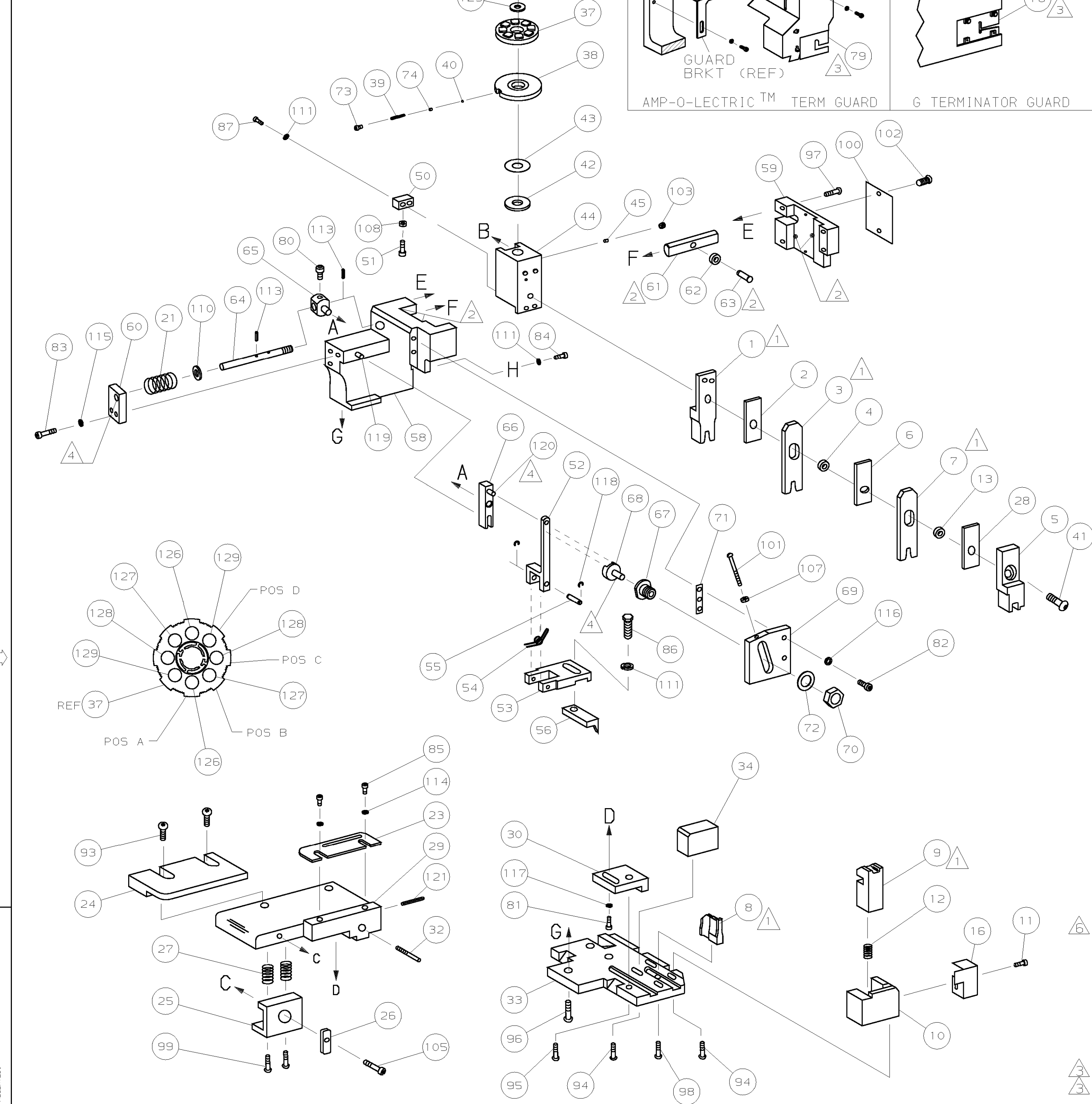

- 1 RECOMMENDED SPARE PARTS.
- 2 GREASE LIGHTLY.
- 3 GUARD MUST BE IN PLACE WHEN OPERATING APPLICATOR IN A BENCH MACHINE.
- 4 LUBRICATE DAILY USING NO. 20 MACHINE OIL.
- 5. ITEMS WITH QTY OF REF SPECIFIED (EXCEPT ITEMS 78 AND 79) ARE USED ON ITEM 46.
- 6 CUT TO LENGTH AT ASSY.

SOCKET		PIN		CRIMPING DATA				
342542		342543		PAD LTR	CRIMP HEIGHT	WIRE SIZE		
				A	.062 ±.002 [1.57 ±0.05mm]	1.5 mm ²		
				B	.054 ±.002 [1.37 ±0.05mm]	1.0 mm ²		
				C	.050 ±.002 [1.27 ±0.05mm]	0.75 mm ²		
				D	.046 ±.002 [1.17 ±0.05mm]	0.5 mm ²		
WIRE STRIP LENGTH		TERM APPL SPEC	FEED	APPL INSTRUCTION	SET UP GAGE	LAYOUT		
-		114-3010	.650	408-8040	458637-1	L1743		
2	2	2	-	C	354779-6	PIN, WIRE DISC (.3020)D 129		
2	2	2	-	C	9-354778-6	PIN, WIRE DISC (.2975)C 128		
2	2	2	-	C	8-354778-8	PIN, WIRE DISC (.2935)B 127		
2	2	2	-	C	7-354778-1	PIN, WIRE DISC (.2850)A 126		
1	1	1	-	A	986950-1	WASHER, FLAT PRECISION 125		
1	1	1	-	A	217238-1	DOCUMENTATION PACKAGE 124		
1	1	1	-	-	4088040	SF APPL INST 408-8040 123		
1	1	1	-	A	4-21028-0	PIN, SLT SPR (ø.093x.75)ST GDE PL 122		
REF	REF	REF	-	A	1-21030-1	PIN, DOWEL (ø.187x.50)LEVER 120		
REF	REF	REF	-	A	1-21030-6	PIN, DOWEL (ø.187x.1.25)HOUSING 119		
REF	REF	REF	-	A	21045-3	RING, RET "C" (ø.187)FD FING PIN 118		
1	1	1	-	A	21024-5	WASHER, LOCK (#10)ADJ BLOCK 117		
REF	REF	REF	-	A	21024-5	WASHER, LOCK (#10)ADJ PLATE 116		
REF	REF	REF	-	A	21024-5	WASHER, LOCK (#10)FEED GDE ROD 115		
2	2	2	-	A	21024-2	WASHER, LOCK (#4)FRONT STP GUIDE 114		
REF	REF	REF	-	A	5-21028-1	PIN, SLT SPR (ø.125x.50)ADJ ROD 113		
4	4	4	-	A	21024-4	WASHER, LOCK (#8)STRIPPER 111		
REF	REF	REF	-	A	21899-4	WASHER, FLAT (ø5/16)SCREW ADJ 110		
1	1	1	-	A	21018-5	NUT, HEX (NO. 6)HOLDDOWN 108		
REF	REF	REF	-	A	21018-5	NUT, HEX (6-32)FEED ADJ 107		
1	1	1	-	A	22353-8	SCR, SHLD (ø.187x.25)DRAG LEVER 105		
1	1	1	-	A	992031-1	PIN, CLEVIS 104		
1	1	1	-	A	21009-2	SCR, SKT SET (1/4-20x.25 LW)RAM 103		
2	2	2	-	A	21017-2	SCR, DRIVE (#2x.19)ID PLATE 102		
REF	REF	REF	-	A	6-23715-5	SCR, PAN HD (6-32x1.50)FEED ADJ 101		
1	1	1	-	B	461264-1	PLATE, IDENTIFICATION 100		
2	2	2	-	A	3-21002-0	SCR, BHC (10-32x.88)DRAG 99		
1	1	1	-	A	22733-8	SCR, BHC (8-32x.38 LW)ANVIL 98		
REF	REF	REF	-	A	2-21002-9	SCR, BHC (10-32x.75)CAP 97		
REF	REF	REF	-	A	2-22733-8	SCR, BHC (1/4-20x.62)HOUSING 96		
REF	REF	REF	-	A	2-21002-7	SCR, BHC (10-32x.50)5G ADJ BLOCK 95		
4	4	4	-	A	2-21002-2	SCR, BHC (8-32x.50)TERM H DWN 94		
2	2	2	-	A	2-21002-3	SCR, BHC (8-32x.62)R STP GDE 93		
1	1	1	-	A	1-21002-7	SCR, BHC (6-32x.38)CAM 91		
1	1	1	-	A	7-21000-9	SCR, SHC (4-40x.19)STRIPPER 90		
2	2	2	-	A	2-21000-7	SCR, SHC (8-32x.48)HOLD DOWN 87		
1	1	1	-	A	2-22603-0	SCR, HEX HD (8-32x.31)FEED FINGER 86		
2	2	2	-	A	1-21000-3	SCR, SHC (4-40x.25)F ST GUIDE 85		
1	1	1	-	A	2-21000-7	SCR, SHC (8-32x.50)STRIPPER 84		
REF	REF	REF	-	A	3-21000-7	SCR, SHC (10-32x.75)FEED ROD 6D 83		
REF	REF	REF	-	A	3-21000-6	SCR, SHC (10-32x.62)FD ADJ BLK 82		
1	1	1	-	A	3-21000-4	SCR, SHC (10-32x.38)5G ADJ BL 81		
REF	REF	REF	-	A	3-21000-4	SCR, SHC (10-32x.38)PIVOT BLK 80		
-	REF	-	-	B	455749-1	GUARD, WINDOW 79		
REF	-	-	-	B	679532-1	INSERT, GUARD 78		
1	1	1	-	A	690603-1	SPRING, ASSIST 74		
1	1	1	-	A	23030-1	SCR, SHC (6-32x.25 SL)INS DISC 73		
REF	REF	REF	-	A	458109-1	WASHER, SPECIAL 72		
REF	REF	REF	-	A	690517-1	SPACER 71		
-3	-2	-1	U/M	DWG SIZE	PART NO	DESCRIPTION		
QTY REOD PER ASSY		PARTS LIST						ITEM NO

LEADMAKER		MECH POST FEED		MECH PRE FEED		MECH PRE FEED		
-1								
-2	BENCH MODEL K							
-3	BENCH MODEL G							
REF	REF	REF	-	B	22594-8	NUT, HEX (1/2-20) 70		
REF	REF	REF	-	B	240628-1	PLATE, ADJUSTMENT 69		
REF	REF	REF	-	B	240626-1	SHAFT, PIVOT 68		
REF	REF	REF	-	B	240633-1	BUSHING 67		
REF	REF	REF	-	A	455680-1	LEVER, INTERMEDIATE 66		
REF	REF	REF	-	B	240629-1	BLOCK, PIVOT 65		
REF	REF	REF	-	A	240632-2	SCREW, ADJ FEED ROD 64		
REF	REF	REF	-	B	240659-3	PIN, CAM ROLLER 63		
REF	REF	REF	-	B	240658-1	ROLLER, CAM 62		
REF	REF	REF	-	B	454398-2	ROD, FEED 61		
REF	REF	REF	-	A	454178-1	GUIDE, FEED ROD 60		
REF	REF	REF	-	C	454220-1	CAP, RAM 59		
REF	REF	REF	-	D	454485-1	HOUSING 58		
1	1	1	-	B	458537-2	PAWL, FEED 56		
REF	REF	REF	-	B	240624-1	PIN, FEED FINGER 55		
REF	REF	REF	-	B	691499-1	SPRING, FEED FINGER 54		
REF	REF	REF	-	B	690541-1	HOLDER, FEED FINGER 53		
REF	REF	REF	-	A	455679-1	LEVER, TERMINAL FEED ARM 52		
1	1	1	-	A	811242-2	BUMPER, HOLDDOWN 51		
1	1	1	-	A	690753-1	SPACER, TONKER 50		
1	-	-	-	B	690602-6	CAM, PRE-FEED 1 5/8 ST 49		
-	1	-	-	B	690602-5	CAM, PRE-FEED 1 1/8 ST 48		
-	-	1	-	B	690501-4	CAM, POST-FEED 1 5/8 ST 47		
1	1	1	-	B	459456-1	APPLICATOR, BASIC (SUBASSY) 46		
1	1	1	-	A	690191-1	PLUG, NYLON 45		
1	1	1	-	C	455673-1	RAM 44		
1	1	1	-	A	690125-1	WASHER, LAMINATED 43		
1	1	1	-	A	690124-1	WASHER, RAM 42		
1	1	1	-	A	7-21002-9	BOLT, CRIMPER (5/16x1.00) 41		
1	1	1	-	A	23241-6	BALL, STEEL 40		
1	1	1	-	A	690170-1	SPRING, COMPRESSION 39		
1	1	1	-	C	690142-1	DISC, INSULATION 38		
1	1	1	-	D	354777-1	WIRE DISC, PLASTIC 37		
1	1	1	-	A	22480-5	WASHER, SPRING 36		
1	1	1	-	B	690212-1	POST, RAM 35		
1	1	1	-	B	690786-3	SUPPORT, TERMINAL 34		
REF	REF	REF	-	D	455675-1	PLATE, BASE 33		
1	1	1	-	A	690432-3	SCREW, ADJUSTMENT 32		
REF	REF	REF	-	B	455689-1	BLOCK, STRIP GUIDE ADJ 30		
1	1	1	-	C	458144-8	PLATE, STRIP GUIDE 29		
1	1	1	-	C	455888-1	SPACER, FRONT SHEAR DEP 28		
2	2	2	-	A	1-22284-0	SPRING, DRAG 27		
1	1	1	-	B	240793-1	LEVER, DRAG RELEASE 26		
1	1	1	-	B	240792-1	DRAG, TERMINAL 25		
1	1	1	-	D	5-690504-1	GUIDE, STRIP (REAR) 24		
1	1	1	-	A	690438-1	GUIDE, STRIP (FRONT) 23		
-	-	1	-	B	690472-2	STRIPPER 22		
REF	REF	REF	-	A	4-22284-9	SPRING, FEED RETURN 21		
1	1	1	-	A	679218-1	STRIPPER WIRE STOP ASSY 20		
1	1	1	-	B	458949-4	STRIPPER 19		
1	1	1	-	B	318563-1	GUARD, CHIP, FRONT 16		
1	1	1	-	B	2-238011-6	SPACER, BLOCK CRIMPER 13		
1	1	1	-	A	5-22280-0	SPRING, SHEAR 12		
1	1	1	-	B	690461-1	STOP, SHEAR 11		
1	1	1	-	C	468798-1	HOLDER, SHEAR (FRONT) 10		
1	1	1	-	C	462006-3	SHEAR, FLOAT (FRONT) 9		
1	1	1	-	C	356122-1	ANVIL 8		
1	1	1	-	C	9-683454-0	CRIMPER, SIZING 7		
1	1	1	-	C	455888-1	SPACER, SIZING TOOL 6		
1	1	1	-	C	122399-1	DEPRESSOR, SHEAR (FRONT) 5		
1	1	1	-	B	238011-4	SPACER, BLOCK CRIMPER 4		
1	1	1	-	C	6-456134-6	CRIMPER, INSULATION 3		
1	1	1	-	C	1-455888-5	SPACER, CRIMPER 2		
1	1	1	-	C	4-458141-4	CRIMPER, WIRE 1		
-3	-2	-1	U/M	DWG SIZE	PART NO	DESCRIPTION		
QTY REOD PER ASSY		PARTS LIST						ITEM NO