

PART NAME: KNOB      SCALE: 1:1      DATE: 1/18/05      DR. BY JAM

DAVIES MOLDING COMPANY  
CAROL STREAM, ILLINOIS 60188

P/N	1506-G
MOLD #	1505/1506/2813
CAVITY	1506
CORE	1506
PIN	BP1506-G
SPRING	I2281

THIS DRAWING IS THE PROPERTY OF DAVIES MOLDING COMPANY, IS SUBMITTED SOLELY AS A DESIGN OR ENGINEERING PROJECT. WE ACCEPT NO RESPONSIBILITY WHATSOEVER FOR THE PRACTICAL APPLICATION OF THE PIECES MADE TO THIS DESIGN.

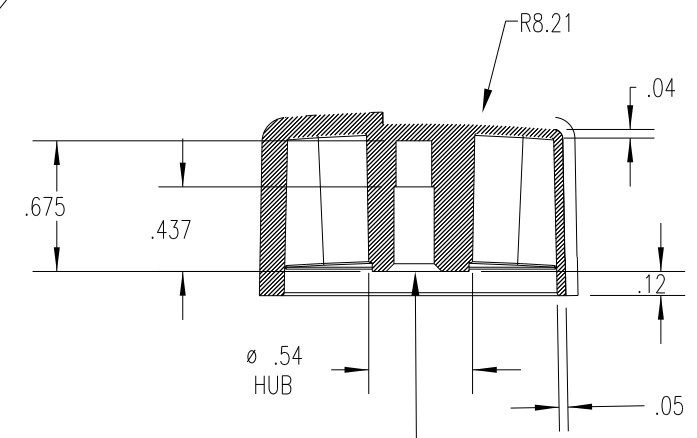
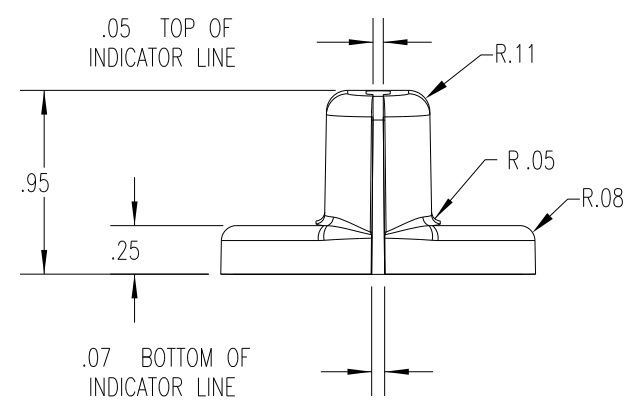
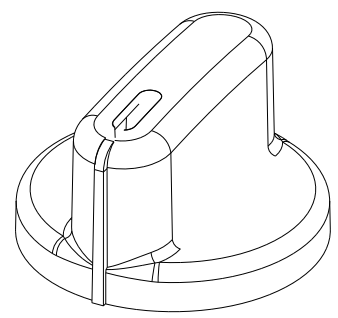
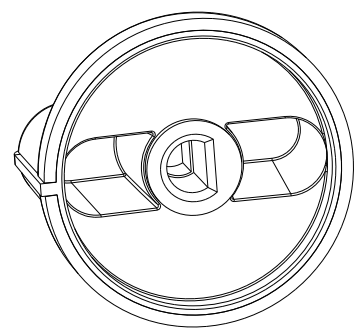
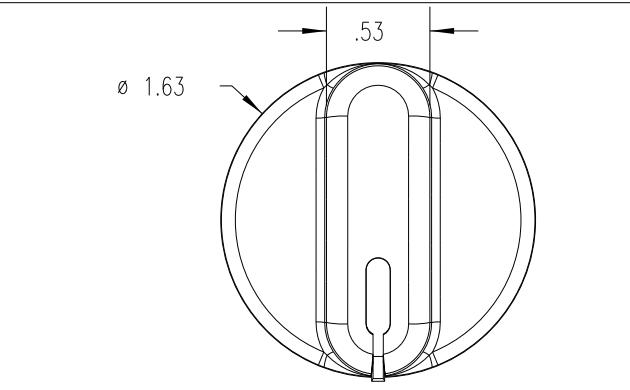

SPRING I2281 TO ACCOMODATE A  $\phi$  .250 SHAFT  
FLATTED TO .182/.179  
(APPLY SPRING AT PRESS) (A)

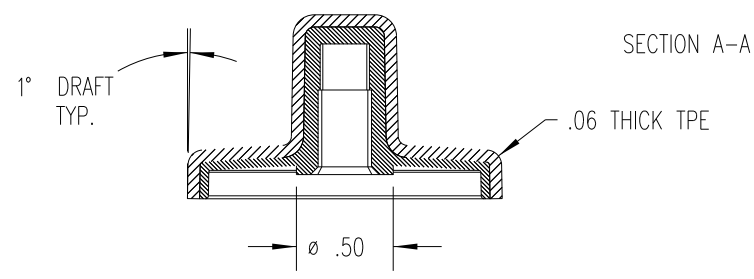
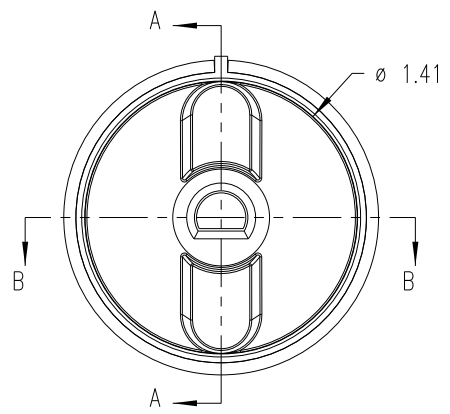

SECTION B-B

SUBSTRATE MATERIAL: POLYPROPYLENE (CLD )  
COLOR: WHITE (PC23083)

OVERMOLD MATERIAL: TPE (TPE3)  
COLOR: BLACK (PC-301) (B)

TOLERANCES: UNLESS OTHERWISE SPECIFIED	DO NOT SCALE DRAWING	C	MOLD # WAS 1506	JAM	12/14/09
		B	ADDED COLOR # PC23083, PC-301	DS	10/16/06
DECIMALS: X.XXX $\pm$ .005 X.XX $\pm$ .015	MM: X.XX $\pm$ 0.15MM X.X $\pm$ 0.4MM	A	ADDED: (APPLY SPRING AT PRESS)	DAD	10/20/05
FRACTIONS $\pm$ 1/64	ANG. $\pm$ 1°	-	WAS SK1506-02	JAM	1/17/05
CHANGES					