

# 承認書

## SPECIFICATION FOR APPROVAL

客戶(Customer): \_\_\_\_\_  
客戶料號(Customer P/N): \_\_\_\_\_  
機種編號(Files No.): \_\_\_\_\_  
機種型號(Model No.): RB-2030008G-046LR-E  
品名(Description): 喇叭  
規格(Specification): 8Ω 1.0W

客戶承認欄 (Customer Authorization Signature)	供應商 (Supplier Audit)		
	Approver	Checker	Author
			謝淑芬
	日期: 2019 年 03 月 05 日		

### Revision History

Version	Date	Description	Author
A0	2019-03-05	初始版本	謝淑芬

**DONGGUAN FUXIN ELECTRONIC CO., L.T.D.**

**S P E C I F I C A T I O N**

Above Measuring condition under temperature : 25~35℃ R.H. 25 ~75%. According to standard GB/T9396-1996

# DONGGUAN FUXIN ELECTRONIC CO., L.T.D.

## S P E C I F I C A T I O N

	Model	RB-2030008G-046LR-E										
1	Type	Dynamic Speaker										
2	Dimension	Outline Dimension Shall Be As Shown In Fig(1).										
3	Weight	Approx 3.0 Grams.										
4	Magnet	Material	Nd-Fe-B									
5	Impedance	8 ± 15% Ohm at 1000Hz. 1V										
6	Power Rating	Normal	1.0W	Maximum 1.5W								
7	FO	670±20% Hz										
8	S.P.L.	96±3dB/1.0Watt 0.1Meter. Average At1000,1200,1500,2000 Hz.										
		Measurement Method Shown In Fig(2).										
9	Frequency Range	F0~20,000Hz.Average SPL-10dB. Frequency Response Fig (3).										
10	Distortion	10% Maximum At 1000Hz. 1.0W.										
11	Abnormal Sound Test	Must be Normal Tested by 2.83 Volts. Sine wave for50~5kHz										
12	Polarity	Diaphragm Shall Move Forward When Apply a Positive DC.										
		Red “+” or“ Marked” Terminal										
13	Operating Temperature	-20°C to +55 °C										
14	Storage Temperature	-25 °C to +65 °C										
15	Reliable Test											
After any following test leave speakers at room temperature for 1 hour, SPL shall not deviate by ±3 db from initial value												
15-1	Load Test	white noise for 96 hours at 1.0W input power.										
15-2	High Temperature Test	+65±2 °C 96hours										
15-3	Low Temperature Test	-25±2 °C 96hours										
15-4	Humidity Test	+40±2 °C relative humidity 90~95%R.H 96hours										
15-5	Vibration Test	Frequency 30 ±15 Hz, Amplitude 1.5 mm for 2 Hours per axis(x. y. z axis)										
15-6	Temperature Cycle test	- 25~ +65 °C 5 Cycles Temperature test.										
<table border="1" style="width: 100%; border-collapse: collapse;"> <tr> <td style="width: 25%;">DATE</td> <td style="width: 25%;">SPEC.NO</td> <td style="width: 25%;">Version</td> <td style="width: 25%;">Page</td> </tr> <tr> <td style="text-align: center;">2019-03-05</td> <td style="text-align: center;">SCM</td> <td style="text-align: center;">A0</td> <td style="text-align: center;">2/5</td> </tr> </table>					DATE	SPEC.NO	Version	Page	2019-03-05	SCM	A0	2/5
DATE	SPEC.NO	Version	Page									
2019-03-05	SCM	A0	2/5									
Model : RB-2030008G-046LR-E												

# DONGGUAN FUXIN ELECTRONIC CO., L.T.D.

## SPECIFICATION

16: Drawing(Fig1) Unit: mm Tolerance:±0.3mm

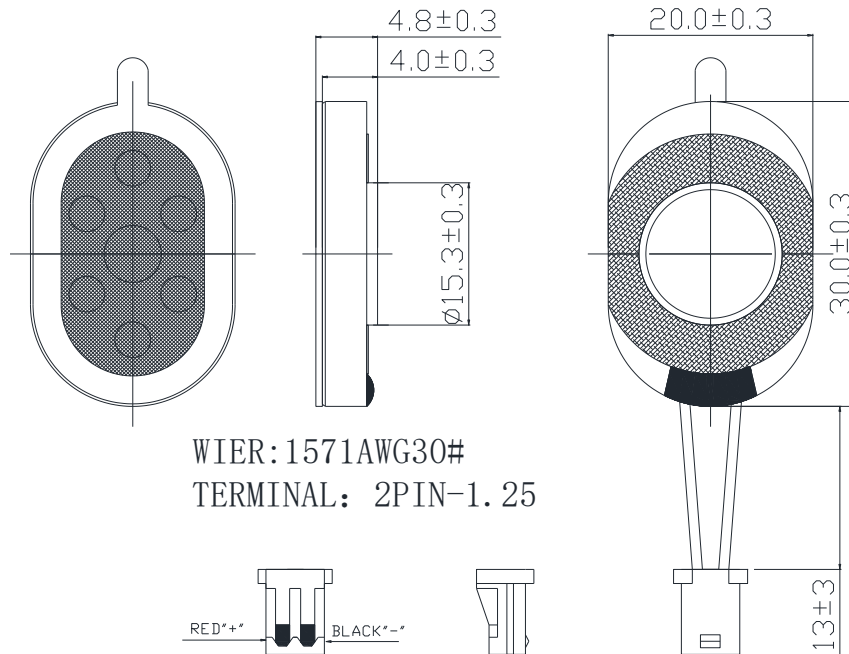

### 17. Speaker Construction

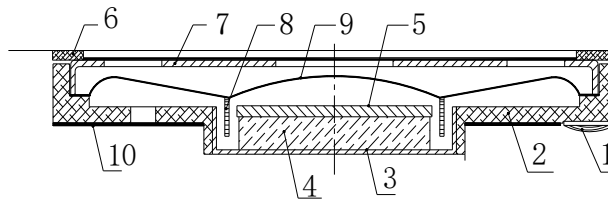

NO	PART NAME	MATERIAL	Q'TY
1	TERMINAL	FR-4	1
2	FRAME	PBT	1
3	YOKE	SPCC	1
4	MAGNET	Nd-Fe-B	1
5	WASHER	SPCC	1
6	EVA	EVA	1
7	COVER	SPCC	1
8	VOICE COIL	COPPER	1
9	DIAPHRAGM	PEN	1
10	CLOTH	CLOTH	1

DATE	SPEC.NO	Version	Page
2019-03-05	SCM	A0	3/5

### 18.Measurement Method Fig(2).

## SPECIFICATION

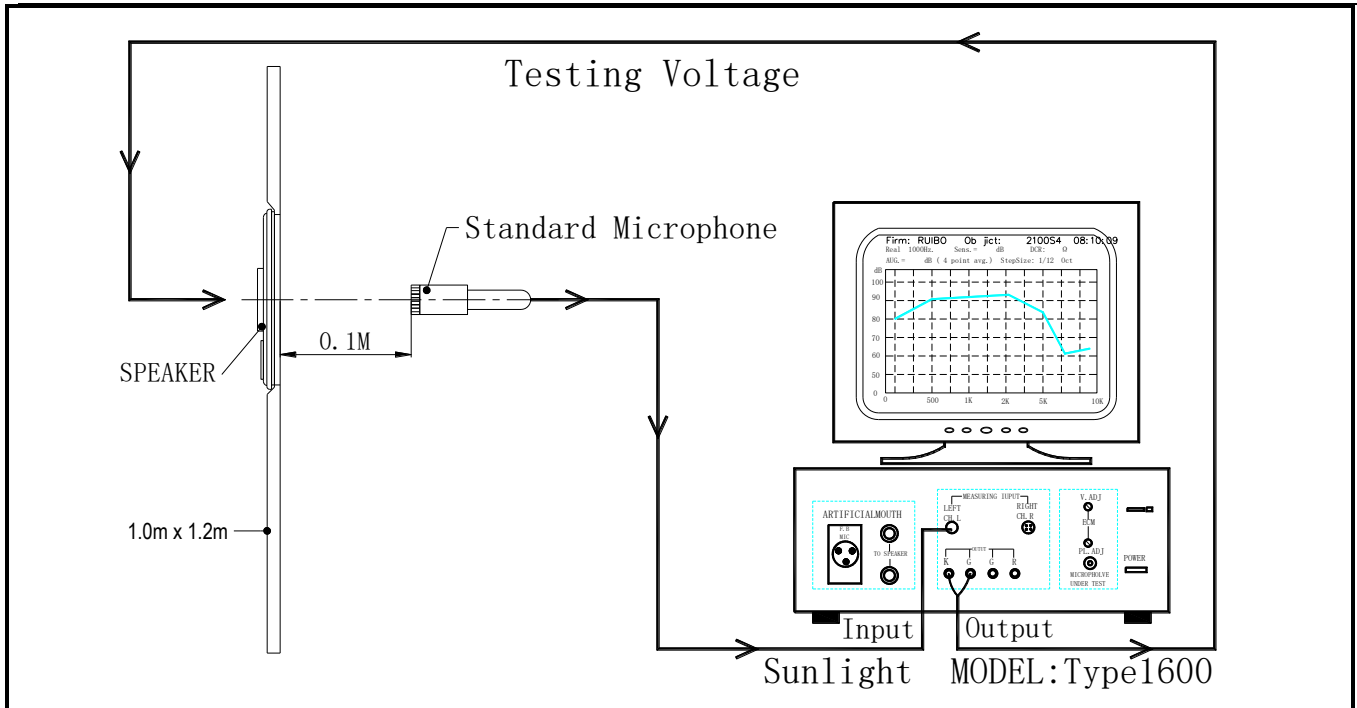

19. Test baffle Diagram

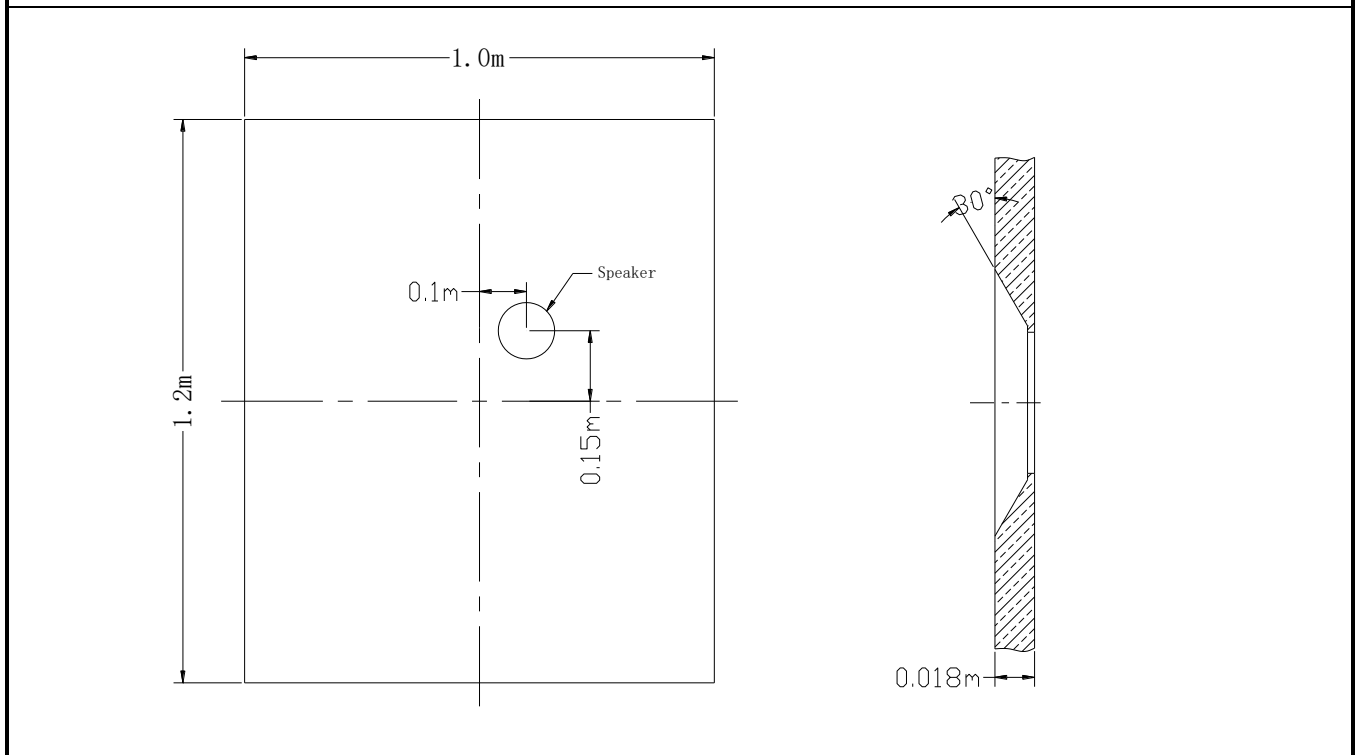

DATE	SPEC.NO	Version	Page
2019-03-05	SCM	A0	4/5

20. Frequency Resonance Fig (3).

# DONGGUAN FUXIN ELECTRONIC CO., L.T.D.

## SPECIFICATION

Firm:1                      Model:1                      DATE:05-15-2012    TIME:08:45:20  
 Real 1000Hz Sens.= 97.8dB SPL Pass    F.R.: Pass    DCR: 9.72Ω Pass  
 Average SPL= 96.8dB SPL Pass (1000;1200;1500; 2000Hz)    Sweep Speed: 1/12 Oct.

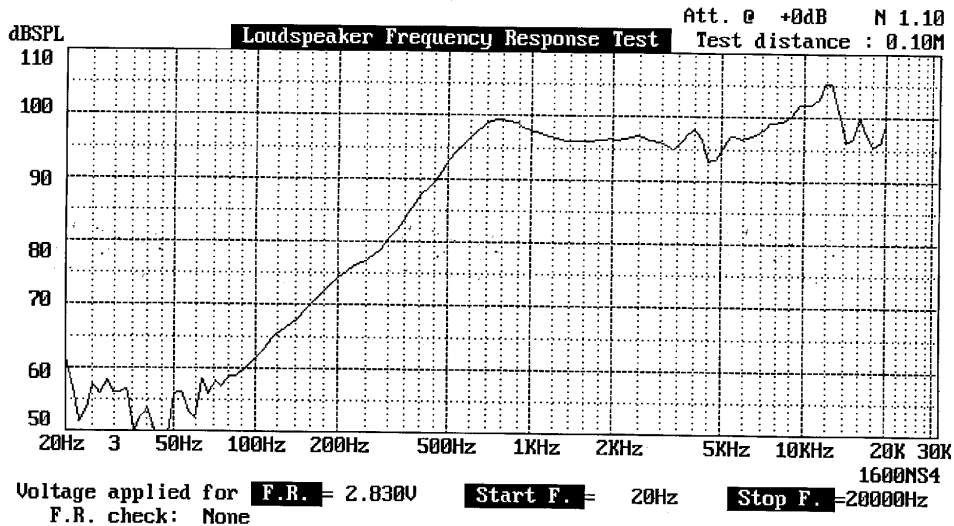

### 21. AC Impedance curve

Firm:1                      Model:1                      DATE:05-15-2012    TIME:08:37:01  
 Start Freq. = 20Hz    Stop Freq. = 10000Hz    Sweep Speed: 1/12 Oct.  
 ACV = 1.000V    ACZ = 9.20 Ω @ 1000Hz. (Real)  
 Fo = 661Hz; Qm = 2.13; Qe = 8.95; Qt = 1.72; DCR = 8.60Ω.

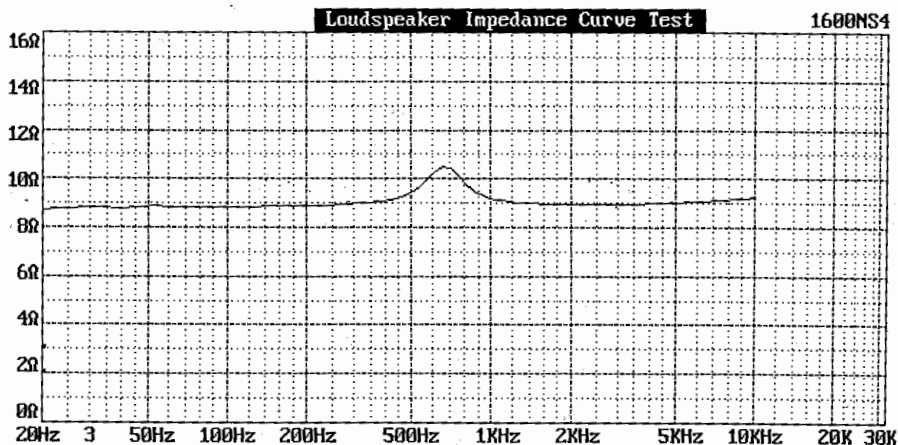

DATE	SPEC.NO	Version	Page
2019-03-05	SCM	A0	5/5