

- 1
- 2
- 3
- 4
- 5
- 6
- 7
- 8
- 9
- 10
- 11
- 12**
- 13
- 14
- 15
- 16
- 17
- 18

MATERIAL
Glass-fibre reinforced polyamide based (PA) technopolymer, black colour, matte finish.

STANDARD EXECUTIONS
- **TTA-A**: zinc-plated steel M10 screw, nut and washer.
- **TTA-SST**: AISI 304 stainless steel M10 screw, nut and washer.

FEATURES
Maximum tightening torque for screw assembly 35 Nm.

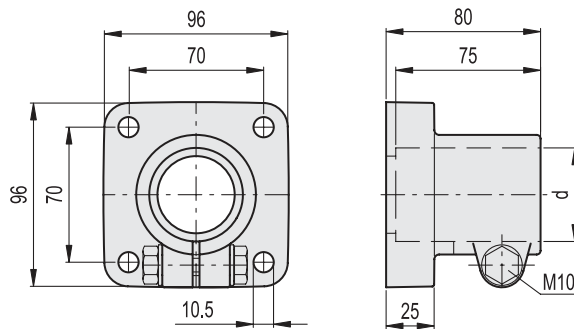

Conversion Table	
1 mm = 0,039 inch	
d	
mm	inch
48.3	1.90

TTA-A				METRIC
Code	Description	d Tube (mm)	d Tube (BSP/GAS)	
419650	TTA.48-A	48.3	1"1/2	260

TTA-SST				INOX STAINLESS STEEL METRIC
Code	Description	d Tube (mm)	d Tube (BSP/GAS)	
419651	TTA.48-SST	48.3	1"1/2	260

Levelling elements and supports